

MarForm



Mahr

FORMTESTER

MMQ 400-2

MarForm MMQ 400-2 UNIVERSAL FORM MEASURING MACHINE

- MarForm MMQ 400 is suitable for universal use for extensive workpiece evaluation according to DIN ISO 1101
- High precision measuring axes in Z and X make every form measuring task possible

This is what we mean by **EXACTLY.**

- 0 +



EXACTLY

IN OUR VIEW, FORM DEVIATION IS NOT A QUESTION OF PERCEPTION. **THAT IS WHY WE HAVE MARFORM**



To ensure problem-free functionality and durability of a workpiece, the key factors are its dimensions and, above all, its form. Requirements in terms of roundness, flatness, straightness, coaxiality or run-out - particularly when it comes to axis-symmetrical workpieces - are becoming increasingly strict. These requirements can only be reliably tested by using high-precision formtesters optimized for this purpose. Whether you are dealing with fuel injection technology, microelectronics, precision mechanics or medical technology, the key functional components are becoming ever smaller and ever more precise. To enable the production department to take advantage of the specified tolerances, measuring uncertainty must be kept as low as possible. MarForm helps you to reduce process costs without increasing testing costs, thanks to innovative instruments with the highest possible level of automation, flexibility, and precision. MarForm offers the ideal combination for all requirements.

MarForm. FORMTESTER MMQ 400

MarForm MMQ 400-2	4
Overview of MMQ 400-2 Versions	12
Overview of Standard Form Measuring Machines	11
Software Modules for MarForm. MarWin	12
MarWin Software Wizards for MarForm	13
Software Options	
Software Option. Roughness measurement	16
Software Option. Contour measurement	17
Software Option. Path control	21
Software Option. Cam analysis	22
Software Option. Diameter measurement	23
Software-Option. Dominant Roundness Waviness	24
Software Packages	
Software Package. Velocity analysis for roller bearing components	26
Software Package. Lead/Twist	28
Software Package. Piston measurement	29
Software Package. Commutator analysis	32
Measuring Strategies. Possible solutions	33
Probes	
MarForm. Probe T20W	36
MarForm. Probe T7W	38
Accessories	
MarForm. Clamping and chucking devices	40
MarForm. Equipment tables, other accessories	41
MarForm. Testing and calibration standards	42

MarForm MMQ 400-2

METROLOGY YOU CAN RELY ON, FOR THINGS YOU RELY ON.

There are many aspects of our daily lives where we rely on technical components functioning correctly. Take, for example, the ABS braking system, fuel injection system and the gear box of a car, the drive of a PC, the compressor in an air conditioning system, the blade of an electric razor, or the landing flaps of an aircraft. For moving components, it is vital they work together smoothly if they are to function efficiently over long periods of time. To ensure this is the case, axis-symmetrical workpieces with tight tolerances are required. Compliance with these tight tolerances can only be verified by using a precision formtester that has been specifically optimized for these applications. MarForm helps you to reduce process costs without increasing testing costs, thanks to innovative instruments exhibiting the highest possible precision and reliability. MarForm offers the ideal combination for all requirements

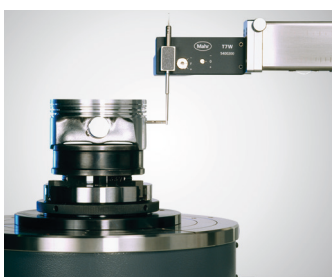
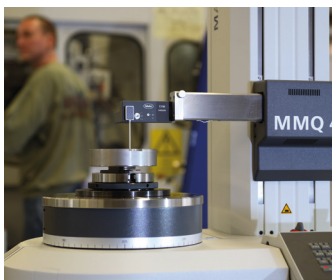

MarForm MMQ 400 SERIES

Even faster, ever better, even more robust

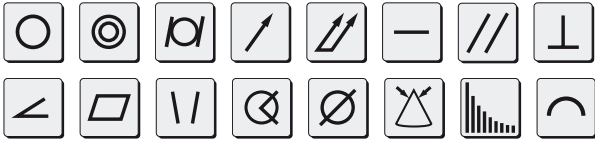

The MMQ 400 series supports fully automatic measurement of form and positional deviations as per DIN/ISO 1101 such as roundness, straightness, parallelism, coaxiality, run-out, cylindricity, and taper. Our Formtester machines are equipped with a precision rotary spindle as well as horizontal and vertical straightness measuring axes of various lengths. This series of universal Formtesters has all the tools you need for measuring a whole range of workpieces. An array of different options and accessories makes the process of adapting to special workpiece geometries straightforward and easy. MarWin AdvancedForm software offers easy operation with maximum flexibility.

Precision you can only benefit from!

Everyone is familiar with the problem of demonstrating capability or calculating measuring uncertainty - the measuring instrument's technical data cannot be used to demonstrate its suitability for a specific measuring task. This data is generally obtained under virtually perfect environmental conditions and on ideal workpieces or stand-ards.

As the market leader for reference Formtesters for many decades, Mahr has demonstrated the accuracy that can be achieved in this regard.

Thanks to innumerable acceptance tests and capability studies conducted for customers worldwide, Mahr has unrivalled expertise on the requirements that measuring instruments have to meet. Today, we will therefore be making repeated mention of the useful accuracy of a measuring instrument. This represents the precision that can be achieved under real-life conditions.

Once the "theoretical" data of many measuring instruments had been shown to be more than adequate for most measuring tasks, it was our objective to increase the useful accuracy by reducing the instrument's sensitivity to external influences.

The main factors influencing the measuring instrument's sensitivity are user operation and the environment.

The operating factors that are of relevance include measuring force, probe arm angle, zenith, clamping/fixturing of the workpiece, alignment, measuring point location, measuring strategy and measuring parameters. The measuring system needs to ignore incorrect values and must be able to set correct values independently of the operator. The software is also vital for reducing the impact of operator actions. It must be easy to use, support flexible programming and protect against unintentional changes.

Improvements in useful accuracy and the widening of the range of applications — these enhancements were at the forefront of development work for the MMQ 400.

Developers were able to use tried-and-tested components in some cases.

The very successful motor-driven **T7W** used in the **MMQ400's** predecessor and **MFU 100/800** reference formtesters is incorporated in the new design.

The CNC-controlled **T7W** probe negates any operator influence by automatically switching the measuring direction, setting the probe arm angle and changing between contact elements. The extremely small measuring force and exceptional linearity help enhance the measuring accuracy.

MarWin ProfessionalForm software package is also being used successfully in the high-end sector in hundreds of installations. However, an environment has been developed specifically for the **MMQ 400** which uses wizards and interactive teach-in programming to create optimized programs quickly and easily. We gathered experience from four generations of **FORM-PC** software platform, representing thousands of installations. The knowledge has been used wisely in the development of the new **AdvancedForm** environment. New functions such as automatic edge detection decrease measurement uncertainty and increase reproducibility while ensuring operation is straightforward and user-independent.

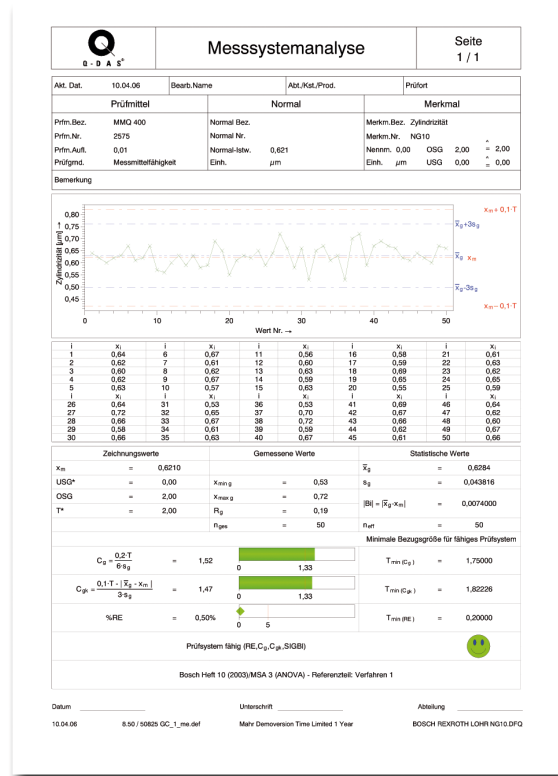

Quality assurance is based on capability studies.

MarForm MMQ 400-2

Absolutely robust and highly precise

The entire construction of the **MMQ 400** has been designed with robustness, stability and resistance to external influences in mind. The basic data for the machine represents the new benchmark in this class of Formtester.

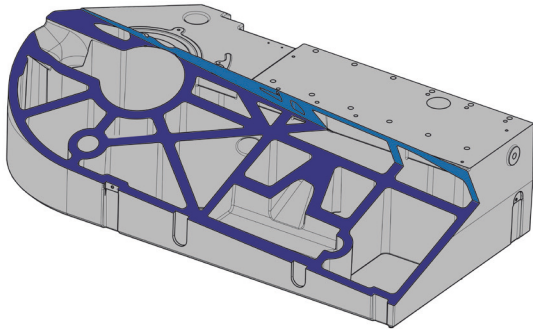

Base unit

The base unit serves as the 'foundation' of each measuring instrument. The high mechanical stability of the **MMQ 400** is ensured by a highly stable steel body with an internal reinforcing structure in which the mechanical rotational axis is embedded.

Vertical measuring axis

The vertical axis has been developed completely from scratch. It is also enclosed in a steel body and is aligned precisely to the rotational axis using special control elements. Particular attention has been paid to the long-term stability of this critical alignment to ensure that it is resilient to environmental influences. Like all mechanical components, the column has been optimized in CAD using the Finite Element Method.

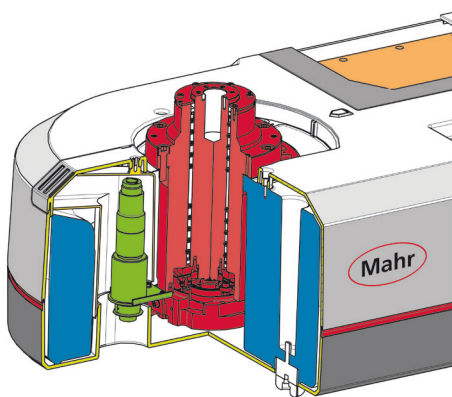

Thermal encapsulation

Temperature changes are the arch enemy of precision measurement. However, conditions in the measuring room cannot always be perfect. The **MMQ 400** is ideal when conditions are less than optimal. The use of homogenous materials ensures that the **MMQ 400's** geometry remains accurate and consequently, thermal expansion uniform, even if temperatures fluctuate. Both the base unit and the vertical axis are also

thermally encapsulated. Brief changes in the ambient temperature therefore have only a minor effect on measurement results. Internal heat sources (motors and electronics) are also thermally insulated and arranged so that the heat that they radiate cannot influence the measuring axes.

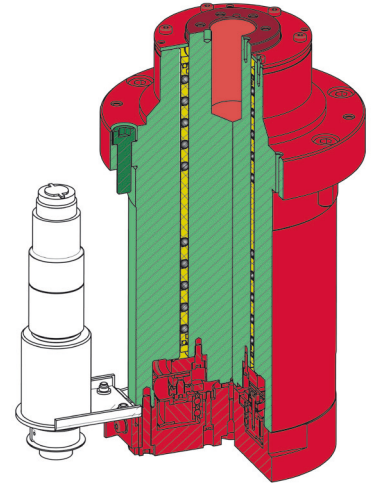

Mechanical bearings from Mahr: Up to 70x less sensitive than air bearings but just as accurate

Mahr is the leading manufacturer of ultra-precise bearings for rotating and lifting movements and supplies customers worldwide. Our customers are from the fields of mechanical engineering, precision engineering, optics, medical technology and production of electronic parts. **Mahr** produces well over 100,000 rotary stroke bearings each year. **Mahr** has also been producing high-precision air bearings for more than 60 years. Through its unique technology, **Mahr** has been able to combine the benefits of air bearings with the robustness of mechanical bearings.

With air bearings, the interplay of the components is distributed by means of an air gap over a very large area. The high integration this yields supports exceptional radial run-out properties - but only if external influences are kept within limits. External influences such as forces arising from the drive or an irregular load distribution or from vibrations in the environment introduce forces into the bearing. The impact this has on accuracy depends on the rigidity of the bearing. This is very low in the case of air bearings due to their very nature.

With mechanical bearings, the balls between the rotor and stator establish a direct mechanical connection. This increases rigidity 70-fold which ensures external influences are minimal. The limited number of contact points reduces the level of integration, therefore mechanical bearings are less precise.

However, **Mahr's** decades of experience has been combined with the use of special production techniques and materials to produce mechanical bearings of the same quality as an exceptionally good air bearing. This quality is maintained even under difficult environmental conditions!

Size and flexibility

The **MMQ 400** has a large measuring volume. This is advantageous when measuring large precise workpieces, but also provides safety reserves and flexibility in a whole number of ways. The table has a load capacity of 60 kg and the large tabletop enables you to use a wide variety of clamping and chucking devices (incl. those for eccentric load-ing). Loading is not at all problematical thanks to the column position-ed at the far right. The long measuring paths support measurements in a variety of positions, e.g. including beyond the center of the C-axis in order to ascertain true parallelism. A large measuring volume also means greater precision with higher reserves and greater resistance to external influences. This is a key benefit of the **MMQ 400**.

After all, who knows what components you will need to measure in the future?

Compact design

Despite the extremely generous measuring volume, the **MMQ 400** has a much smaller footprint than other, comparable units. The electronics are integrated in the unit and the fact that no compressed air is required means that the **MMQ 400** only requires a power source (115 V or 230 V). Consequently, there is sufficient space available to ensure that the working environment is as ergonomic as possible.



MarForm MMQ 400-2



Ergonomic workplace

Usually, the **MMQ 400** is operated on a work table with a basic area of 1,150 x 750 mm (45.3 x 29.5"), i.e. a table of the size of a Euro pallet. This work table provides sufficient space for a monitor, keyboard and accessories and offers adequate leg room over the entire width and depth so the user can work comfortably, even when seated. Roller-type cabinets that can be positioned next to or beneath the work table are also available. If you need to view drawings or draw up measuring plans and measuring programs on a regular basis, the preparation table with separate monitor and keyboard provides an efficient working option.

Where space is at a premium, an equipment table with a footprint of around 850 x 550 mm (33.5 x 21.7") is also available for the production floor.

The machine can also be operated easily when standing. The ergonomic manual control panel and sensitive joystick round off the overall impression of a very user-friendly unit.

Speed and cost-effectiveness

Speed is not an issue. But combining speed and accuracy has proved to be far trickier when it comes to axes control. Through put time when measuring a workpiece is now more important than ever. The Z-axis of the **MMQ 400** permits movements at up to 100 mm/s - more than three times faster than any other form measuring instrument. The adjustable speeds and accelerations, fewer alignment operations thanks to sophisticated algorithms, and simultaneous movement of up to three axes all combine to save valuable time. This reduces the costs per measurement significantly.

Safety reserves built in

If you travel fast, you need to be able to stop fast, too. When designing the new **MMQ 400** a concentrated effort was made to protect both the operator and the machine. A whole array of safety features has been included to ensure trouble free operation. These range from passive safety measures to prevent possible crush points, and extend to the probe protection contact (when the permissible measuring range is exceeded), thermal overload protection and collision protection switch, right through to the emergency off switch with triple relay technology, counter-current braking and defined "crush zones". If there were such a thing as a Euro NCAP Crashtest for measuring instruments, the **MMQ 400** would definitely have been awarded five stars.

Serviceability

If a service issue does arise, all service-relevant assemblies can be accessed easily from the outside. This means short repair times and low repair costs even after many years of operation. But to ensure that repairs are not necessary in the first place, we can offer you maintenance services, maintenance agreements or extended warranties.

An **MMQ 400** after all, is almost an investment for life...

The **MMQ 400** is a universally applicable form measuring machine for both shop floor and precision lab use

The **MMQ 400** can be flexibly used for comprehensive workpiece assessment according to DIN ISO 1101. The high-precision measuring axes in both vertical (Z) and horizontal (X) direction allow for any type of form measurement.

MarForm MMQ 400 for:

- high precision workpieces
- extremely long workpieces
- big and heavy workpieces
- use on both the shop floor and in precision labs

There are five types of **MarForm MMQ 400**. Each one is tailored to perfectly suit your specific requirements:

- motor-driven or manual centering and tilting table,
- vertical (Z) axis of either 500 mm (19.7 in) or 900 mm (35.4 in) of length with a horizontal (X) axis of 280 mm (11 in) of length or
- 350 mm (13.8 in) vertical (Z) axis with a 180 mm (7.1 in) horizontal (X) axis,
- digital path measuring system for reading out the linear scales in X and Z direction for highly reproducible measuring results.

With the tailstock option, many shaft-like workpieces can now be clamped between two centers for measurement instead of being held just on one end in a rim chuck. The tailstock thus cuts down the alignment time for workpieces from several minutes to just a few simple steps and further increases the efficiency of your MarForm MMQ 400-2.

Tailstock option

The **MMQ 400** model with motor-driven CNC centering and tilting table is now offered with an additional motorized tailstock for clamping shafts between centers.

Tailstock option,

available for machines of type MarForm MMQ 400 CNC with a Z-axis length of Z = 500 mm or Z = 900 mm.

Clamping shafts between centers drastically reduces the time required for alignment. As the MarForm MMQ 400 features a motor-driven CNC centering and tilting table, any other high precision workpieces can also be tested on "tailstock" machines.

The optional tailstock now turns the universally applicable form measuring machine into a high-precision shaft measuring machine.

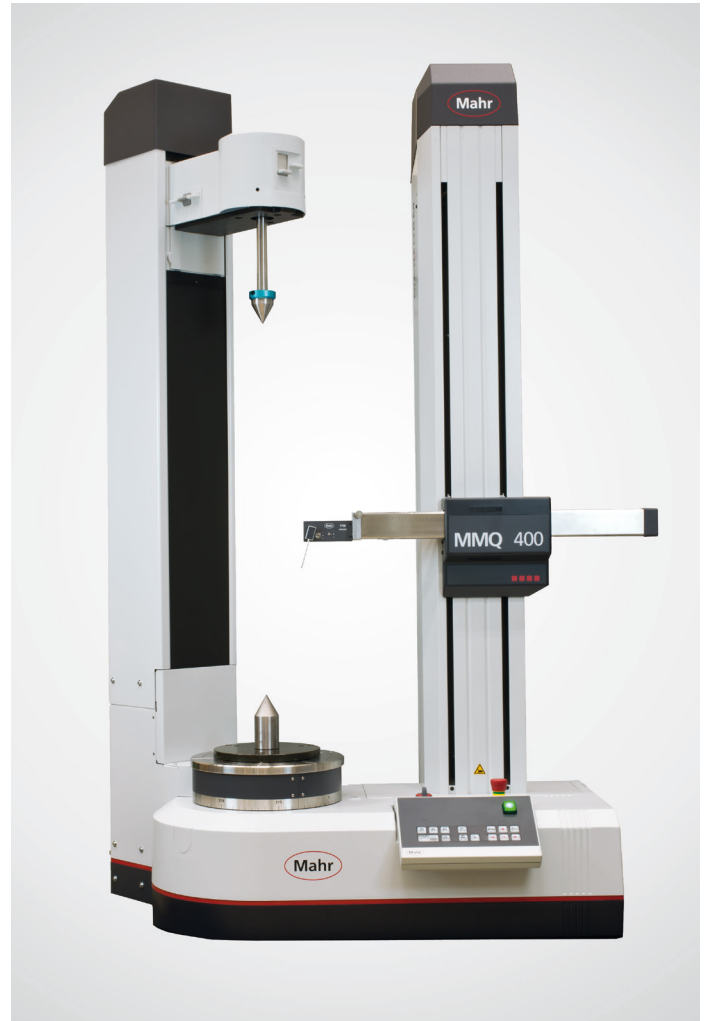

The motorized tailstock and the motor-driven CNC centering and tilting table can be operated alternately, thus increasing the already high flexibility of MarForm MMQ 400 and widening its amazing range of applications even further.

MarForm MMQ 400-2

Versions



Type A

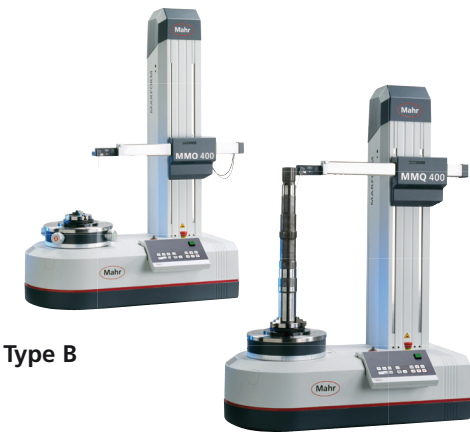

Type B

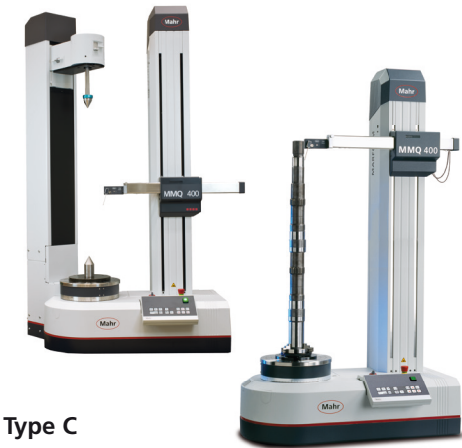

Type C

Measuring station Order No. Instruments Order No.

Type A
MarForm MMQ 400 measuring station
with Z = 350 mm and X = 180 mm

MMQ 400-2 5440770
MMQ 400-2 CNC 5440780

Type B
MarForm MMQ 400 measuring station
with Z=500 mm and X=280 mm
and large machine volume

MMQ 400-2 5440771
MMQ 400-2 CNC 5440781

Type C
MarForm MMQ 400
with Z = 900 mm and X = 280 mm

MMQ 400-2 CNC 5440782
MMQ 400-2 CNC WL 5440787

x = standard
o = optional
- = not provided

Manual centering and tilting table	CNC centering and tilting table	X-axis, motor-driven measuring axis	Z-axis, motor-driven measuring axis	Linear scale in Z and X	EasyForm evaluation software	AdvancedForm evaluation software	ProfessionalForm evaluation software	T20W probe	T7W probe	Motorized tailstock
X	-	X	X	X	X	X	O	X	O	-
-	X	X	X	X	X	X	O	-	X	-
X	-	X	X	X	X	X	O	X	O	-
-	X	X	X	X	X	X	O	X	O	-
-	X	X	X	X	X	X	O	-	X	-
-	X	X	X	X	X	X	O	-	X	X

MarForm MMQ 400-2

Overview of Standard Form Measuring Machines



Formtester	MMQ 400-2 Z = 350 mm X = 180 mm	MMQ 400-2 Z = 500 mm X = 280 mm	MMQ 400-2 Z = 900 mm X = 280 mm
Order No.:	5440770 5440780	5440771 5440781	5440782
Roundness measuring device, C-axis			
Roundness deviation ($\mu\text{m}+\mu\text{m}/\text{mm}$ meas. height)**	0.02 + 0.0005	0.02 + 0.0005	0.02 + 0.0005
Roundness deviation ($\mu\text{m}+\mu\text{m}/\text{mm}$ meas. height)*	0.01 + 0.00025	0.01 + 0.00025	0.01 + 0.00025
Axial run-out deviation ($\mu\text{m}+\mu\text{m}/\text{mm}$ meas. radius)**	0.04 + 0.0002	0.04 + 0.0002	0.04 + 0.0002
Axial run-out deviation ($\mu\text{m}+\mu\text{m}/\text{mm}$ meas. radius)*	0.02 + 0.0001	0.02 + 0.0001	0.02 + 0.0001
Centering and tilting table			
	manual /automatic	manual/automatic	automatic
Table diameter (mm)	285	285	285
Table load capacity, centric (N)	600	600	400***
Rotational speed (rpm)	0.2 to 15	0.2 to 15	0.2 to 15
Angle resolution (scale)	32,768,000	32,768,000	32,768,00
Vertical unit, Z-axis			
Motor-driven, measuring path length (mm)	350	500	900
Straightness deviation / 100 mm meas. path (μm)**	0.15	0.15	0.15
Straightness deviation / total meas. path (μm)**	0.3	0.4	0.9
Parallelism deviation Z/C-axis in tracing direction (μm)	0.5	0.8	2
Measuring speed (mm/s)	<0.1 to 10	<0.1 to 10	<0.1 to 10
Positioning speed (mm/s)	<0.5 to 100	<0.5 to 100	<0.5 to 100
Linear resolution (μm)	0.005	0.005	0.005
Horizontal unit, X-axis			
Motor-driven, measuring path length (mm)	180	280	280
Straightness deviation /100 mm middle meas. path (μm)**	0.4	0.5	0.5
Straightness deviation /total meas. path (μm)**	0.8	1.5	1.5
Perpendicularity X/C-axis (μm)	1	2	2
Measuring speed (mm/s)	<0.1 to 10	<0.1 to 10	<0.1 to 10
Positioning speed (mm/s)	<0.5 to 30	<0.5 to 30	<0.5 to 30
Linear resolution (μm)	0.005	0.005	0.005
Instrument volume			
Distance C/Z - max. interference radius (mm)	220	364	364
Max. test radius external (mm)***	-45 to 135	-15 to 265	-15 to 265
Meas. height external with T20W/T7W (mm)***	361 (475)	511 (625)	911 (1025)
Dimensions/connection data			
Height x width x depth (mm)	1080 x 840 x 550	1330 x 840 x 550	1630 x 840 x 550
Weight (kg)	245	260	300
Mains connection	115 - 230 V +6% -10% 50 / 60 Hz - 60 VA	115 - 230 V +6% -10% 50 / 60 Hz - 60 VA	115 - 230 V + 6% -10% 50 / 60 Hz - 60 VA

* Values as maximum deviation from reference circle LSC, filter 15 upr.

** All values to DIN ISO 1101 at 20 °C \pm 1°C in oscillation-neutral environment; filter 15 upr LSC or 2.5 mm in LSS, 5 rpm or 5 mm/s (0.2"/s) and standard probe arm with ball dia. 3 mm (0.12"). Tested on a standard using compensation algorithms.

*** Workpiece length max. 900 mm, diameter max. 285 mm, center of gravity below the middle
We reserve the right to change technical data.

MarWin

Software Modules for MarForm

AdvancedForm gives you total control over your form measuring station. You can perform positioning, alignment, measurement or documentation tasks with a click of the mouse - and the graphical user interface gives you a constant overview.

As with other Windows® applications, functions can be selected from menu bars with pull-down menus using the mouse.

Many functions, e.g. printing results, loading measuring programs or changing a program step, can be activated simply by clicking the appropriate icons.

With AdvancedForm you always have complete control over the form measuring station. For example, you can track the profile during measurement and intervene if necessary. Operation can be adapted to suit individual requirements, regardless of whether you want to perform a quick single measurement, conduct a program run on a series part or convert a complex measuring task into a measuring program. **AdvancedForm** provides the ideal operating strategy whatever the task.

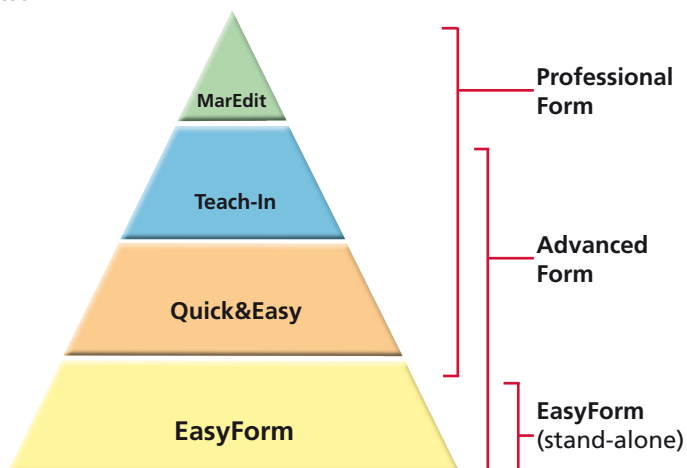

Given that tasks can vary a great deal, no operating strategy is exactly right for every application. Consequently, **AdvancedForm** provides several different operating strategies:

- **Measuring run - Preferences**
for measurements with an existing measuring program
- **Quick&Easy**
for rapid measurements, obtaining a measuring result quickly with the minimum of effort
- **Teach-in programming**
for creating, modifying and running a measuring program with a large number of options
- **MarEdit (optional)**
the operating level for application engineers and trained specialists, for solving the most challenging and complex of tasks

AdvancedForm provides a clear overview of all the required measuring and evaluation parameters. Many of these parameters have default settings which simply have to be confirmed for the majority of measuring tasks. It is, of course, also possible to adapt individual parameters to the relevant task.

AdvancedForm has a powerful **teach-in programming** function to create measuring programs for workpieces that are to be measured repeatedly. It can also be used for measuring runs with special positionings, measurements, evaluations and forms of presentation.

With teach-in programming, as soon as you click an icon - e.g. for a run-out measurement and evaluation - a window opens where you can describe the feature in more detail if necessary (e.g. radial or axial run-out, datum, brief designation, tolerance etc.). The number of measurements and their type (original measurement or new evaluation of profiles already measured) are also specified in this window. Separate windows can be opened to change measuring, evaluation and display parameters, but in many cases this is not necessary because logical defaults that apply to a large number of measuring tasks have already been entered. If different settings are required for specific measuring tasks, the clear way the window is designed helps you to quickly find the correct location and optimize the settings in no time at all.

The layout of a measuring record, for example, can be modified right down to the finest detail.

The color of the profile, reference and borders can be selected individually, and the scaling (in $\mu\text{m}/\mu\text{in}$ per scale division), type of graph (polar or linear, centered or uncentered) and additional display parameters can be set in any combination you choose.

Measuring programs for a series of parts that are to be run repeatedly can be saved and called up at any time (see above).

Informative profile graphs - if required with several profiles in a single graph, displayed in different colors and in different ways - are then immediately available on the large color screen. If you are looking for exact numerical values, you can opt to display the results in a table.

With the new **AdvancedForm**, standard-compliant measurements and evaluations are displayed in a way which is both clear and representative. There is even an interactive layout customization feature with a 3D preview in real time.

MarWin Software Modules in Detail



Preferences view for starting the measuring programs

If you need to carry out form measurements, rather than creating long measuring programs you may prefer to gain direct access to a comprehensive and informative measuring record. In order to be able to do so, it is particularly important for the software to be transparent. Immediately after logging in at the **MarWin** user administration, you are directed to the **MarShell**, a clearly arranged user interface comparable with the Windows Desktop. It is from this MarShell that you start the finished measuring programs in the preferences view. These preferences can be easily identified by means of saved images or graphics. One click is all that is needed to start the measuring program. The **MarShell** is also used to start the measuring wizard module, **Quick&Easy (QE)**.

The **Quick&Easy** wizards provide support for "quick interim measurements" and, with little effort, guide the user quickly to his objective, namely a highly informative measuring record.

A further click results in all **Quick&Easy** wizards that have so far been run being adopted as a chronological sequence into the **MarWin** teach-in program. This sequence merely has to be saved and the measuring program is then ready.

In **AdvancedForm**, additional functions can be added to the measuring program. The following **Quick&Easy** wizards assist in this process:

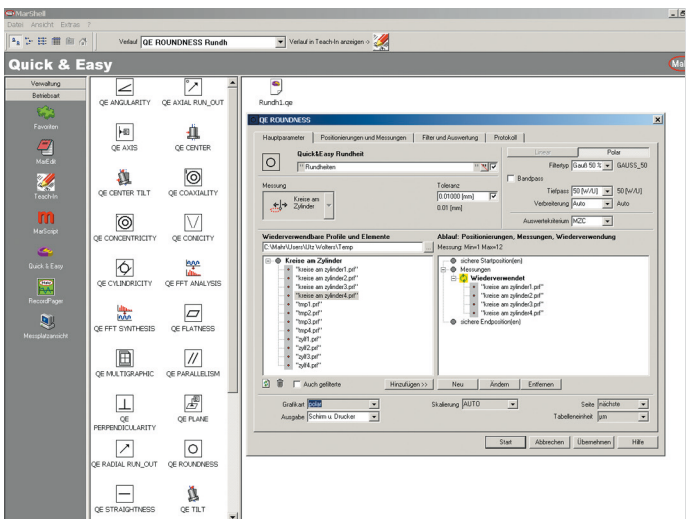

Quick&Easy Roundness



- **QE Determine starting position**
Wizard for organizing and preparing the measurements with selection of the probe elements, messages and display of workpiece / clamping images
- **Measuring station**
For manually controlling the machine's axes and probe arm
- **QE Axial run-out alignment**
Wizard for tilting and leveling the workpiece; based on an axial run-out measurement
- **QE Centering**
Wizard for centering the workpiece; based on a circumferential measurement
- **QE Centering and tilting**
Wizard for centering and leveling the workpiece; based on two circumferential measurements at two different heights

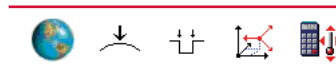

- **QE Set parameters**
Wizard for defining the global and local parameters conveniently
- **QE Zenith**
Wizard for determining the maximum X- or Z-position of a profile

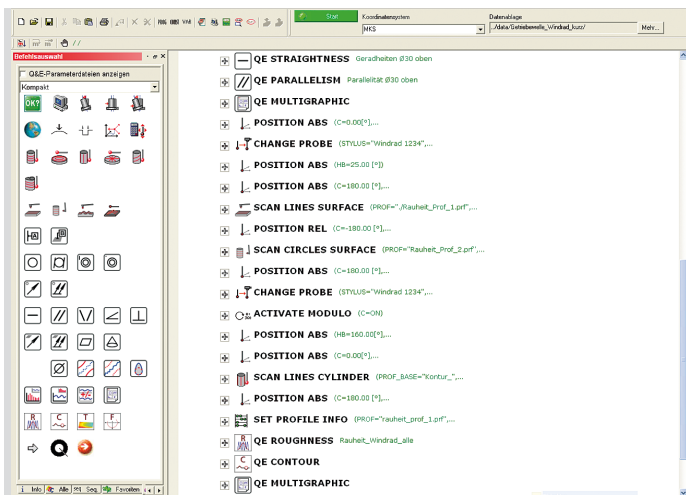

Teach-In Listing

MarWin

Software Wizards

- **QE Edge search**
Wizard for determining an edge position which can then be used to generate a workpiece coordinate system
- **QE Switch coordinate system**
Wizard for defining and naming coordinate systems
- **QE Move to calculated position**
Wizard for moving the probe to a calculated position



- **QE Axis**
Wizard for generating a datum axis; based on at least two circum-ferential measurements performed at different heights or one axial run-out measurement and one circum-ferential measurement
- **QE Plane**
Wizard for generating a datum plane; based on at least two circum-ferential measurements performed at different heights or one axial run-out measurement and one circum-ferential measurement



- **QE Circles on cylinder**
Wizard for polar measurements on the internal or external circumference with the C-axis
- **QE Circles on the flat face/plane**
Wizard for polar measurements with contacting from above or below with the C-axis
- **QE Lines on cylinder**
Wizard for vertical measurements on the internal or external generating line with the Z-axis
- **QE Lines on the flat face/plane**
Wizard for horizontal measurements on the flat face from above or below with the X-axis



- **QE Roundness**
Wizard for measuring, evaluating and recording the roundness; also as local deviation within a sliding window; based on measurements of full and partial circles
- **QE Cylindricity**
Wizard for measuring, evaluating and recording the cylindricity; based on measurements of full and partial circles or straightness measurements along the generating line
- **QE Coaxiality**
Wizard for measuring, evaluating and recording the coaxiality with respect to a datum axis; based on measurements of full and partial circles
- **QE Concentricity**
Wizard for measuring, evaluating and recording the concentricity with respect to a datum profile at the same Z measuring height; based on measurements of full and partial circles



- **QE Radial run-out**
Wizard for measuring, evaluating and recording the radial run-out with respect to a datum axis; based on measurements of full and partial circles
- **QE Total radial run-out**
Wizard for measuring, evaluating and recording the total radial run-out with respect to a datum axis; based on measurements of full and partial circles or linear measurements along the generating line



- **QE Straightness**
Wizard for measuring, evaluating and recording the straightness; also as local deviation within a sliding window; based on linear measurements or a theoretical axis from circular measurements on the generating line
- **QE Parallelism**
Wizard for measuring, evaluating and recording the parallelism relative to a datum axis, datum plane or opposite profile; based on linear and polar measurements or a theoretical axis
- **QE Conicity**
Wizard for measuring, evaluating and recording the conicity relative to a datum axis or opposite profile; based on linear measurements
- **QE Angularity**
Wizard for measuring, evaluating and recording the angularity relative to a datum axis or datum plane; based on linear and polar measurements or a theoretical axis
- **QE Perpendicularity**
Wizard for measuring, evaluating and recording the perpendicularity relative to a datum axis or datum plane; based on linear and polar measurements or a theoretical axis

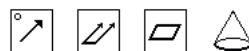

- **QE Axial run-out**
Wizard for measuring, evaluating and recording the axial run-out relative to a datum axis; based on measurements of full and partial circles
- **QE Total axial run-out**
Wizard for measuring, evaluating and recording the total axial run-out relative to a datum axis based on measurements of full and partial circles or linear measurements on an end face
- **QE Flatness**
Wizard for measuring, evaluating and recording the flatness; based on measurements of full and partial circles or linear measurements
- **QE Cone form**
Wizard for measuring, evaluating and recording the cone; based on measurements of full and partial circles or linear measurements. The cone angle can also be computed and output



• **QE Fourier analysis**

Wizard for performing a Fast Fourier Transformation on a polar/ linear profile; result presentation in a histogram or table. Including a tolerance band monitoring function for the amplitude height in the histogram (nominal value read from an ASCII file); RTA analysis based on the FAG standard with calculation and representation of a tolerance band in the Fourier histogram as described in the FAG in-house standard in the form of an RTA analysis

• **QE Fourier synthesis (optional)**

Wizard for generating new profiles from profiles from which some wavelengths have been removed. Instrument for removing any wavelength from a profile. Reversal of a Fast Fourier Transformation and selection of specific wavelengths for generating a new, "synthetic" profile that can then be subject to further evaluation

• **QE Profile arithmetic**

Wizard for calculating profiles and generating new profile information which can then be put to further use. Required in order to determine e.g. the relative thickness profile of two opposite profiles

• **QE Multigraphic**

Wizard for generating multigraphics on a record sheet

• **QE Result export (optional)**

Wizard for exporting measuring results to the Mahr DataTransferTools (optional) and, consequently, to statistical software packages such as qs-STAT, Excel, etc.

• **QE Roughness measurement (optional)**

Wizard for the measurement and evaluation of roughness parameters

• **QE Contour measurement (optional)**

Wizard for the measurement and evaluation of contour features

• **QE Diameter measurement (optional)**

Wizard for the measurement and evaluation of diameter deviation from polar profiles and with LSC evaluation

• **QE QS-STAT (Option)**

Wizard for easy export of result values to the statistics software QS-STAT (separate description upon request)

• **QE Tolerance band evaluation (optional)**

Wizard for defining, measuring and evaluating free forms. The measurement takes place as a comparison to the target profile with the path control or in the "Tracking Mode" for unfamiliar free forms

• **QE Cam evaluation (optional)**

Wizard for defining, importing, measuring and evaluating cam shape and cam-specific features (pg. 22 ff.). The measurement takes place as a comparison to the target profile with the path control or in the "Tracking Mode" for unfamiliar cam geometries.

• **QE Dominant roundness waviness (optional)**

Wizard for the measurement and evaluation of dominant roundness waviness according to MBN 10455. Evaluated are RONWDt, RONWDmax, RONWDc and RONWDn. (separate description upon request)

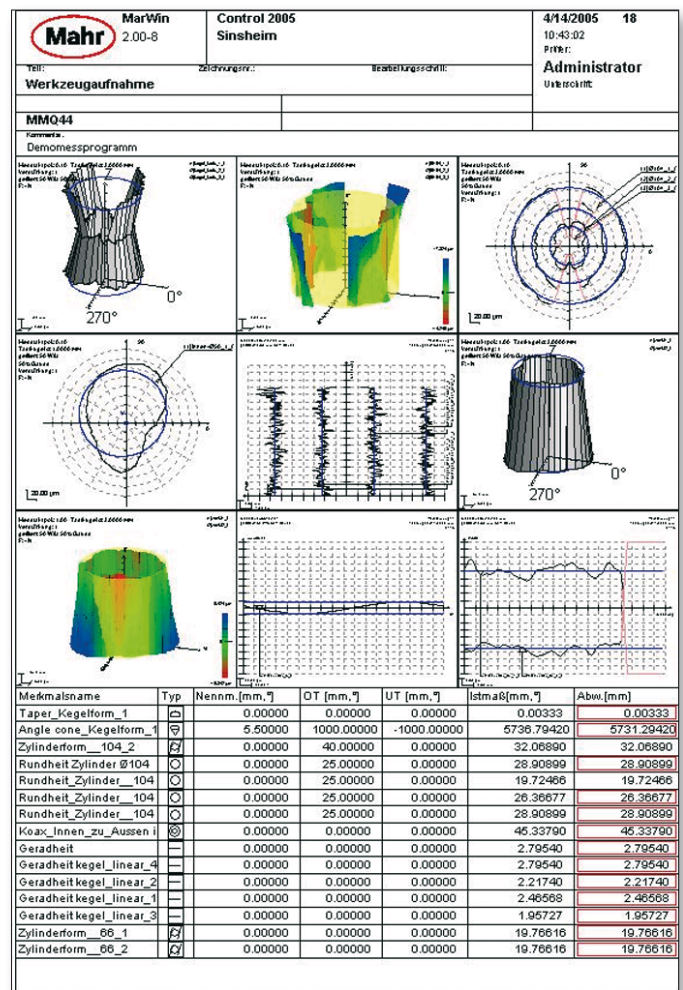

It goes without saying that there is also an informative graphic preview. And on completion of the measurements, of course, you have a comprehensive and informative measuring record.

MarWin

Software Option Roughness Measurement

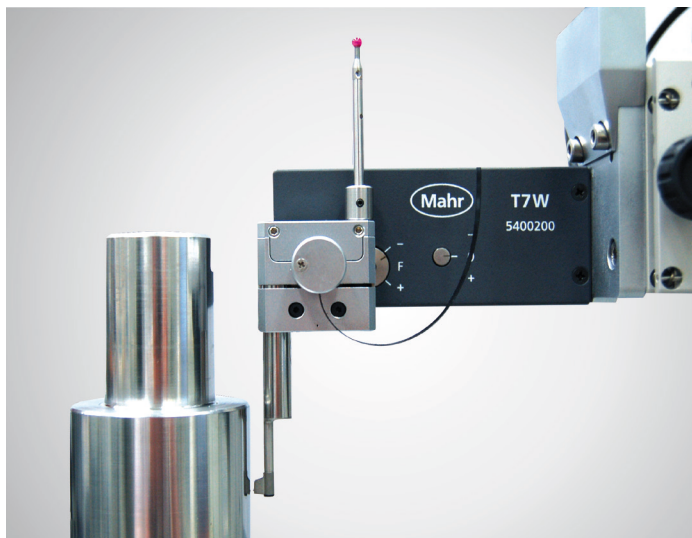

What is more obvious than assessing and documenting the surface roughness parameters of your workpiece while checking it for form and position tolerances?

Why not assess e.g. the Ra and Rz values with a MarForm form measuring instrument?

If you do so, you can be sure of uncompromisingly high quality for the pick-up or probe required for the relevant measuring task is always in optimum measuring position.

Profit from:

- Reduced testing times and costs due to complete workpiece assessment in a single set up and in just one run
- Higher accuracies due to the automatic selection and positioning of the probe or pick-up for each measuring task
- Simple operation due to a software which is equally well suited for surface roughness as well as form and position measurements
- Detailed and telling measuring records
- Well-proven surface roughness metrology combined with equally well-proven form metrology

Delivery scope of:

Option Roughness Measurement for MMQ 400

Order no. 5400240, 5400241

Hardware package

- Roughness probe PHT 6-350 with 90° probe tip, rounding radius 2 µm
- Double probe arm holder unit to support the PHT 6-350 as well as the probe arm for form measurement
- Adapter to connect the PHT 6 to Formtester MMQ 200

Software package

- Software license for roughness evaluation, for use in AdvancedForm
- Software option AdvancedForm for use with MMQ 400

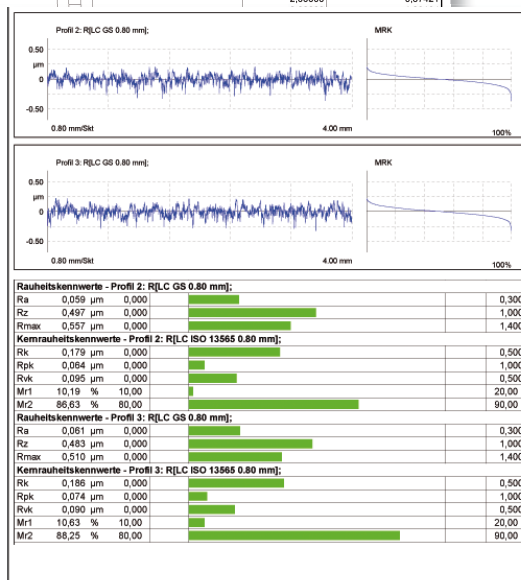
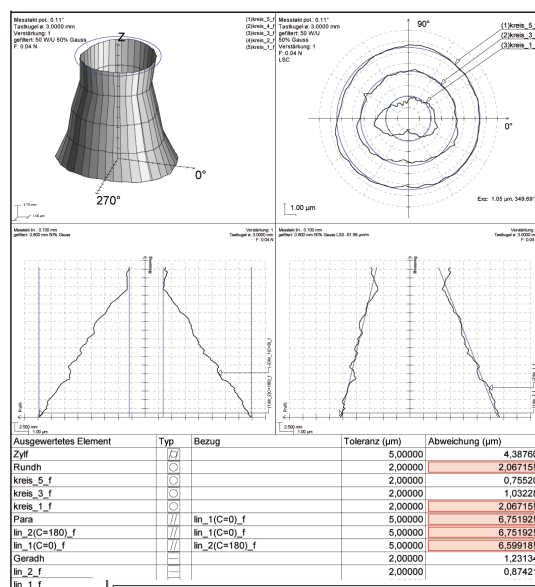

RPHT 6-350 Pick-up	Order no. 6111520
System	Skidded probe
Skid radius	In tracing direction 25 mm, laterally 2.9 mm
Contact point	0.8 mm in front of the probe tip
Measuring range	350 µm
Specification	For level surfaces, For bores from 6 mm Ø to 17 mm depth Grooves from 3 mm width, min. workpiece length = tracing length + 1 mm
Probe tip geometry	2 µm/90° diamond

Software Option Contour Measurements and Contour Evaluation

Industrial production metrology increasingly requires faster and easier measurements of workpiece profiles. The measuring tasks are diverse and constantly require higher precision and optimal measuring strategies of the entire system.

When searching for cost and time oriented solutions of measuring tasks, there is a desire for the measurement of form and position as well as roughness and contour.

Decades of experience in contour metrology as well as numerous wishes and suggestions from our customers have shaped this new generation of units. What began almost 30 years ago with the Conturograph to record contours and compare them with templates has developed today into a contour measuring system of the highest quality and most modern technology. With the Contour Software MarSurf XC 20 and MarSurf XC 2, Mahr customers rely on leading quality and reliability.

What is more obvious than also recording and documenting roughness parameters such as Ra and Rz when testing your workpieces with a MarForm measuring unit? And then, after the measurement of form and location features, to also take care of contour tasks without having to switch the workpiece over to a second measuring station?

Combine the testing of form and position tolerances with the monitoring of contour features and roughness parameters:

With these possibilities, Mahr offers a completely new interpretation of the term "CNC measuring station"!

With the MarForm MMQ 400, the form and position features of the workpiece surface are determined according to ISO 1101 using high-precision roughness and linear axes. A diamond tip records the roughness parameters and a probe tip, common for contour measurements, records the contour by tracing the high-resolution linear axis of the MMQ 400. Based on the software platform MarWin, all features are evaluated and documented.

For the user this means:

No compromises in quality because: The measuring head that is optimal for the respective measuring task always assures the highest accuracy.



Your advantages with MarForm MMQ 400 and the motorized probe T7W.

- **Only with Mahr:** 3-in-1 probe arm for higher accuracy due to automatic selection of the roughness probe, the probe tip for the contour measurement or the probe arm for form and location.
- **Only with Mahr:** Save time and money with only one clamping and one measuring run without operator interference.
- **Only with Mahr:** Easy operation due to one software for form, location and roughness and for contours, all in 3D.
- **Only with Mahr:** MarForm MMQ 400-2 with high-precision linear axes enables high-resolution measuring for recording and evaluating contours.
- **Only with Mahr:** Proven form metrology combined with proven roughness metrology.
- **Only with Mahr:** Clear and detailed records for form, roughness and contour clearly combined on one sheet.

MarWin

Software Option Contour Measurement

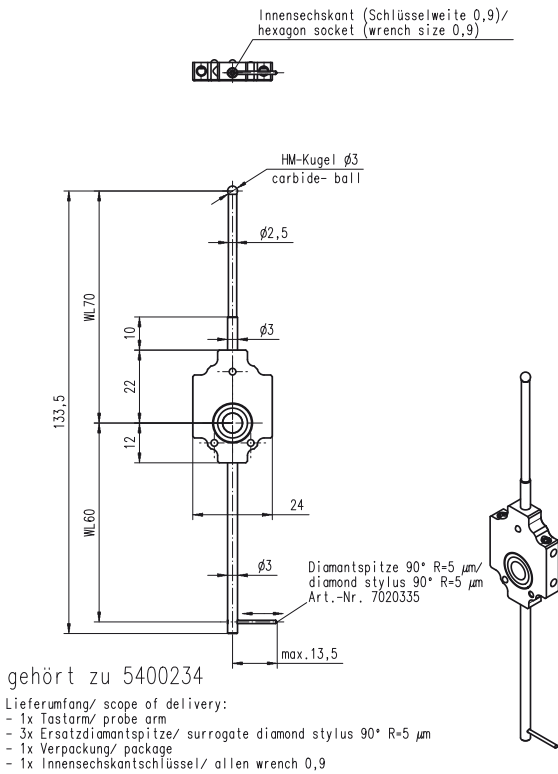

Example of a triple probe arm for form, roughness and contour measuring

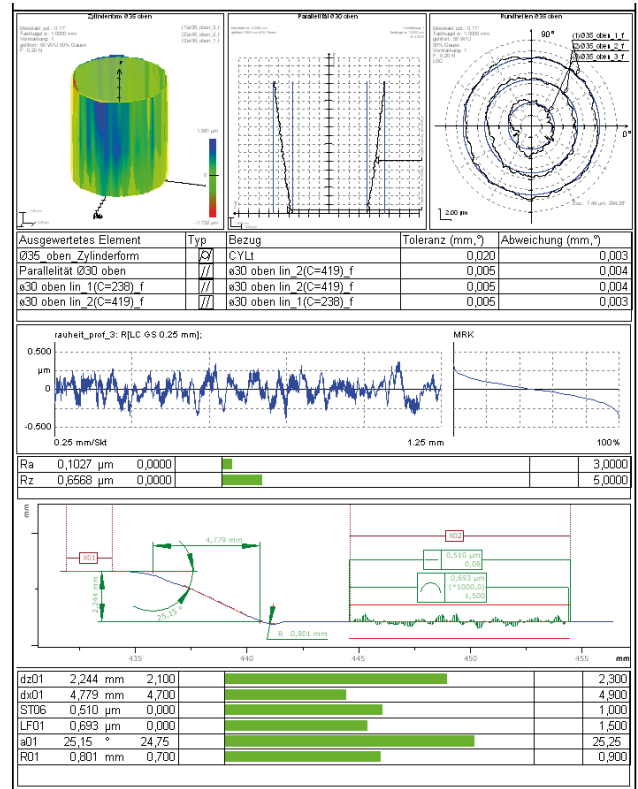

Technical Data

Option contour measurements for AdvancedForm	
Traverse length (in Z)	0.2 mm to 350 mm, 500 mm or 900 mm
Measuring range (in X)	20 mm
Measuring system (in X)	high-precision, incremental measuring system, resolution 0.005 µm
Measuring system (in Z)	high-precision, incremental measuring system, resolution 0.005 µm
Contacting direction (in X)	forwards (+X), backwards (-X)
Traverse direction (in Z)	downwards (-Z), upwards (+Z)
Measuring force of the T7W	adjustable in the MarForm software
Profile inclination to the traverse direction (Z)	70°
Measuring speed (in Z)	0.2 mm/s to 1 mm/s
Probe tip radius	25 µm
Measuring uncertainties U95 when vT = 0.8 mm/sec:	
- Distance	±(3+I/25) µm
- Radius 10 mm	10 µm
- Angle*	3 min

* On plain surfaces (Rz < 2 µm) with inclination ±45° to the Z-axis and side length 5 mm up to 30 mm

Software Option Contour Measurement with MCPC

Even though modern manufacturing processes use sophisticated technology for increasingly complex workpieces, final inspection in a measuring lab still continues to be an important part of quality assurance.

In order to track down even minor errors as early as possible, however, it is indispensable to test workpieces close to the shop floor: By measuring the workpieces in between the different operation steps and manufacturing stages, the stability of the manufacturing process is monitored, making it possible to adopt appropriate measures as soon as action limits are surpassed.

In the past, testing close to the shop floor was performed basically with hand-held measuring equipment, special measuring devices and simple measuring instruments. Today, the high complexity of the parts and the increasingly higher demands on accuracy require quite complex form measuring instruments.

Form measuring instruments usually assess workpiece geometries by moving the probe along a high-accuracy reference axis. So far, contour measurements could only be taken either within the probe measuring range or by repositioning the probe during measurement in accordance with the probe signal (also known as "tracking" or "auto follow"). The latter, however, only worked with speeds below 0.5 mm/s and could not be used with geometries interrupted by bores or grooves.

The new **MCPC (Mahr Continuous Path Control)** of the MMQ 400-2 enables moving along a two-dimensional path (nominal contour) by moving two axes simultaneously. Here, ten-times higher measuring speeds of up to 5 mm/s can be obtained.

The measuring data are continuously recorded in a 3D point cloud. This type of coordinate measurement is thus implemented for the first time ever on a form measuring instrument.

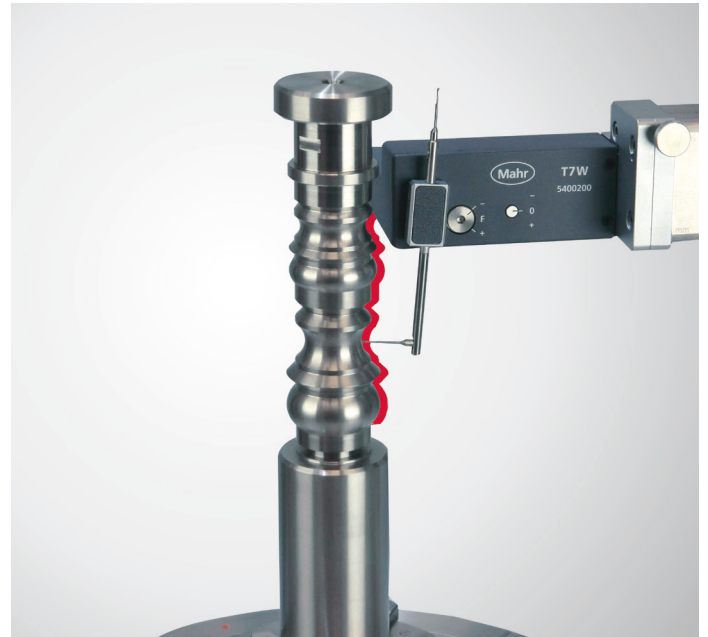

3D contour standard KN100S

The 3D contour standard KN 100 S is also very suitable for the testing of your coordinate measuring machine and your contour measuring unit. The 3D contour standard KN100S is only available from Mahr.

Order no.: 5360581

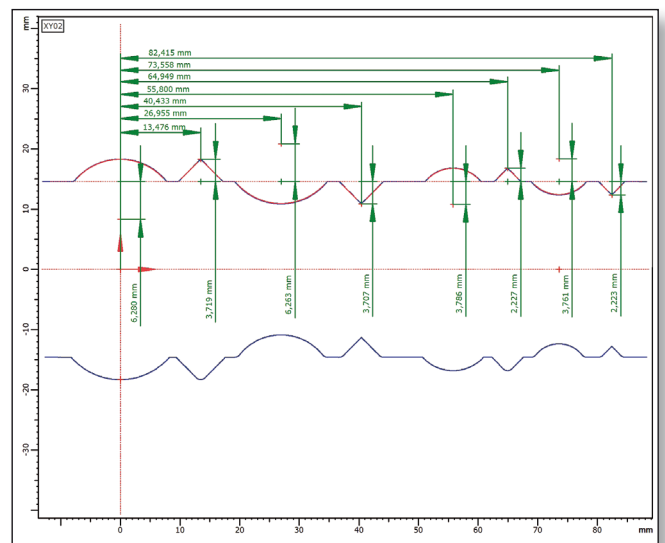
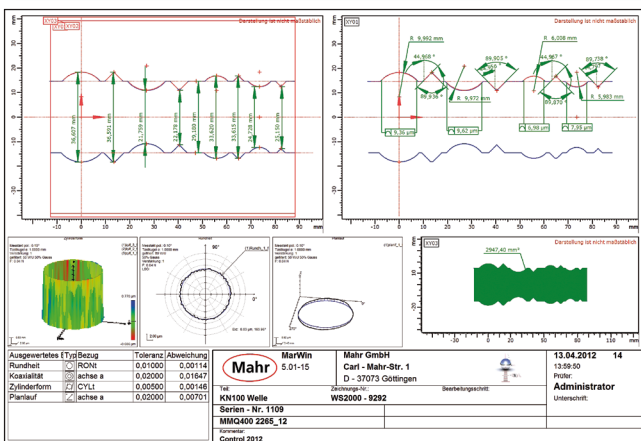

MarWin

Software Option Cam Evaluation

Camshafts make a significant contribution in realizing energy-efficient drive units in a modern powertrain. To meet the increasing demands for precision in the production of camshafts, Mahr has further developed its proven solutions for the measurement and evaluation of form and location tolerances for the testing of the cam shape on camshafts. This new development is now offered for the MarForm measuring machines.

In conjunction with the already established Formtesters for the measuring room, the MarForm series, this new development in the MarWin software represents a major enhancement in the field of camshaft evaluation.

The new generation of the camshaft measurement application has merged all camshaft types in one wizard (Quick&Easy), whether standard, double cams, tripods or eccentric shafts. Concave and convex cam shapes can also be evaluated using this software.

This concentrated functionality allows various cam geometries to be defined by a wizard in one simply described sequence. Through the definition of specific settings, the global parameters, customer-specific measuring sequences, tolerances and evaluations can be standardized.



MMQ 400-2 with camshaft

Areas of Application

A Formtester is required to measure the bearing points of a cam-shaft. As a prerequisite for measuring the cam shape, a path control of the measuring machine in connection with low contact forces is required as well as the inclusion of as many measuring points as possible.

Solve this task with the MarForm **MMQ 400-2** or the **MarForm MFU 100** – the measuring station for high-precision shafts and now also for camshafts. Together with the high-performance software platform MarWin 5 it offers everything needed to completely measure camshafts quickly and efficiently.

The test record is received even more quickly when the camshaft is clamped between centers. The option "motorized tailstock" for **MMQ 400-2** saves lots of time by eliminating the need for work-piece alignment, thus optimizing the measuring process.

The required cam shape can be read as a file or adapted or created in a simple wizard.

MarForm traces this target shape on the cam. You receive your cam profile details together with the user-defined tolerance bands. This graphic can be easily varied with a

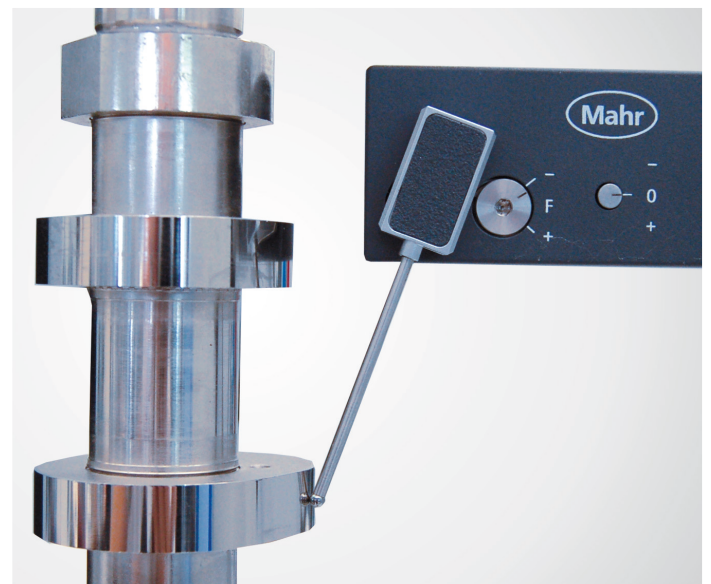

freely selectable form factor between contour representation and the representation of the tolerance band deviation. More cam-specific characteristics such as stroke curves and cam angle can also be evaluated. Special assessments such as the acceleration curve and the velocity curve calculated from the profiles are also included with the scope of this **Quick&Easy CAM**.

The further references for shape and location characteristics can easily be determined with the known AdvancedForm teach-in programming. "What you do is what you get!" is the working principle.

Choose between ball stylus, cutting stylus or disc stylus. Unknown cams are automatically measured by MarForm and can be used as target data for your series (tracking mode).

With this measuring station, workpieces can be tested quickly, efficiently and completely.

Features

- Create your camshaft measuring program quickly and easily
- Attain a high level of measuring reliability thanks to an assistant-guided work method

The MarWin-based measurement and evaluation software, AdvancedForm, offers another new assistant as well. It allows for measurement of the cam shape from a circular movement with X-axis tracking as well as cam shape evaluation and prototyping. The measurement and evaluation of the cam shape fits seamlessly into the user interface of AdvanceForm, where, together with the wizard for form and location measurement, it clearly depicts even very extensive and complex measuring tasks by means of teach-in programming.

This Quick&Easy Cam (QE CAM) is activated by a separate, optional license, so that the scope of the MarForm measuring machine can be easily adapted for future requirements.

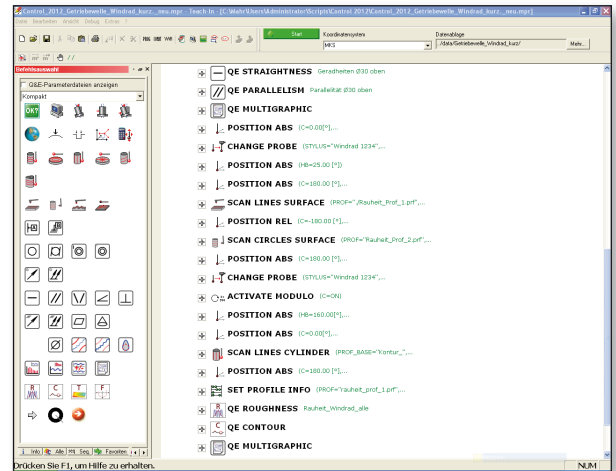

AdvancedForm

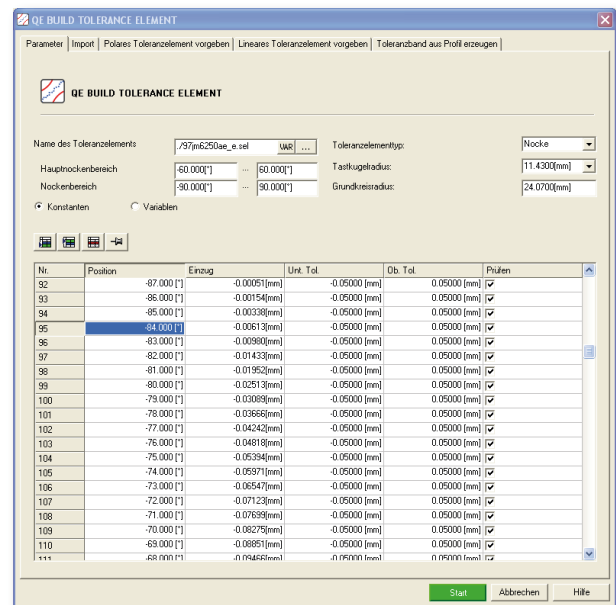

QE BUILD TOLERANCE

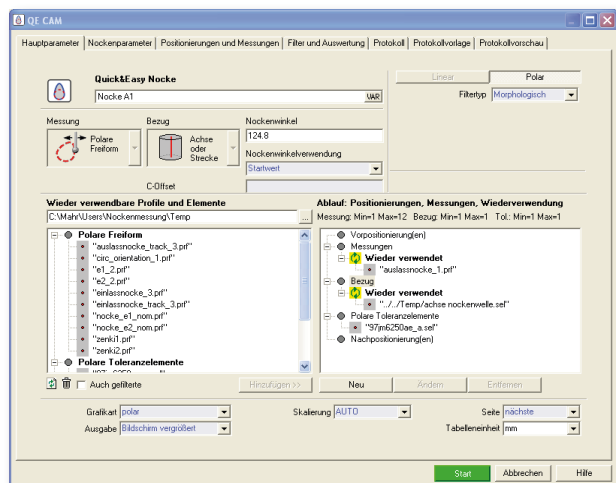

QE CAM

MarWin

Software Option Cam Evaluation

Performance Description

The new option "Cam Evaluation" is offered for the MarForm machine types **MFU 100**, **MFU 110** and **MMQ 400-2**. The measurement takes place using the T7W probe and a tactile probe element. The option "Cam Evaluation" is available for use together with MarWin.

Evaluation/Measurement

- Cam evaluation is carried out with a wizard (**Quick&Easy**) for cam shape measurement and evaluation, with the optional **QE CAM** in AdvancedForm and in ProfessionalForm. The wizard is activated with a separate software license
- Measurement through circular axis movement (C-axis) with implementation of path control (**MCPC**) or with tracing the X-axis of the Formtesters (tracking mode **SCAN CIRCLES CYLINDER**)
- Creation of tolerance band e.g. in MS Excel (not in the scope of the option)
- Loading a tolerance band into **QE CAM** from a file (.txt, .csv formats)
- Measuring a track on the cam with C-axis with X-axis tracking or by reusing an already measured profile
- Comparison/evaluation of the profile deviation with the loaded tolerance band
- Use of morphological filter with conversion to the respective tracing geometry or to the geometry of the flat or roller tappet or conventionally with GAUSS filter

Measuring Record

Determination and output of parameters with the possibility of tolerance monitoring:

- Max. error of the tolerance band
- Form growth (greatest pitch error on the periphery)
- Angular position of the cam to the reference
- Representation of the cam profile as a
 - polar graph
 - linear graph, each with selectable form factor (0 and 1) between 0 and 100 %
- Representation of the first and second mathematical derivative of the cam profile (valve speed and valve acceleration) as a linear graph
- Output of a table with the values/deviations from the cam profile tolerance band

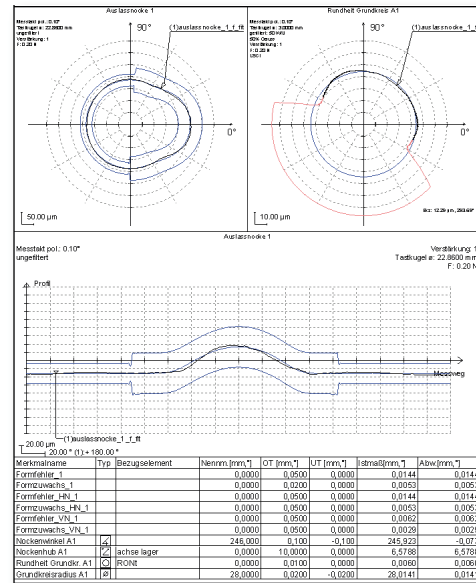

Measuring record: cam shape deviation

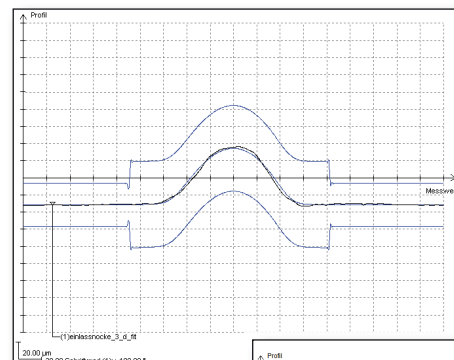

Cam measurement: cam stroke

Cam measurement First derivative: valve speed

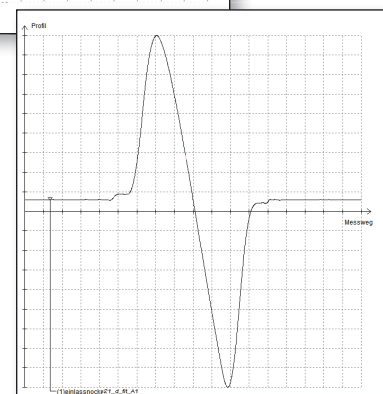

Cam measurement Second derivative: valve acceleration

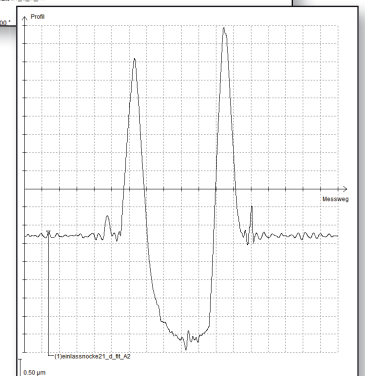

Software Option Diameter Measurement

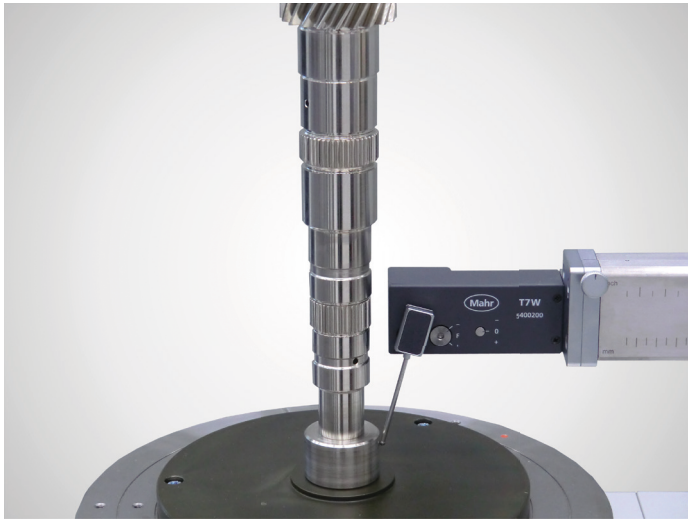

Calibration measurement

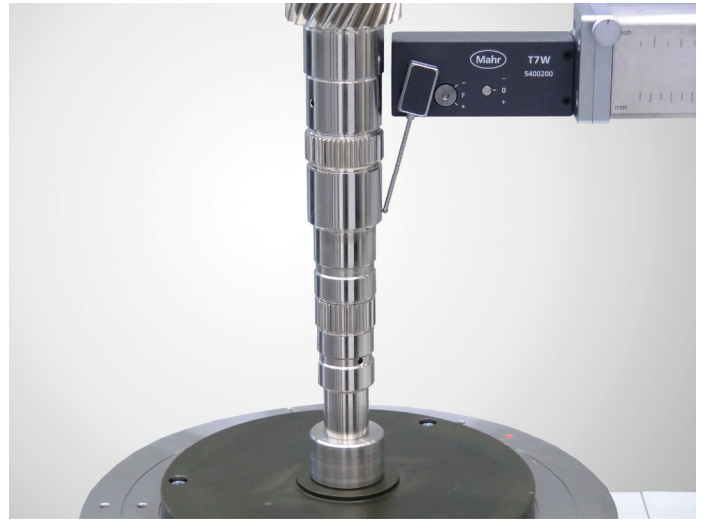

Diameter measurement

Diameter measurements and evaluation with MarForm MMQ 400-2 and the option QE DIAMETER

A wizard, called "Quick&Easy" in the Mahr software, guides the user through the reference measurement and determination of the diameter and creates the corresponding and informative measuring record directly after the evaluation. The measuring record not only includes the diameter measuring results, but also offers a visualization of the roughness deviation.

The calibration measurement and diameter evaluation are based on circular measurement with a high measuring point density of, for example, 3600 points per 360 degrees. The calculation of the reference circle LSC according to the Gaussian method assures a high mathematical reproducibility.

The essential features are:

- Easy operation due to a set-up comparable to QE ROUNDNESS
- Determination of diameter from circle measurements
- Determination of reference from circle measurements
- Outside and inside measurements
- Standard evaluation of the reference circle via LSC
- Evaluation procedures for the diameters to be determined: LSC, MZC, MIC or MCC
- Competent measurements with diameter tolerances of 20 µm
- Output of reference diameter and correction value
- Activation via license (Option: Order no.: 5480190)

With the new option diameter measurement and diameter evaluation for MarForm MMQ 400-2 the performance scope of the form measuring units are expanded with the possibility to evaluate and document diameter deviations in addition to roundness deviation. For this purpose, the measuring probe and the X-axis of the MarForm machine are prepared for this measuring task in a measurement of a preceding calibration measurement.

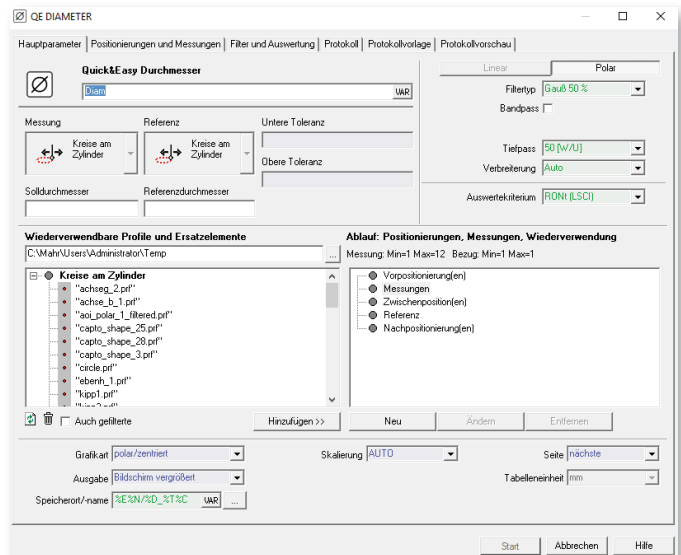

MarWin

Software Option Dominant Roundness Waviness

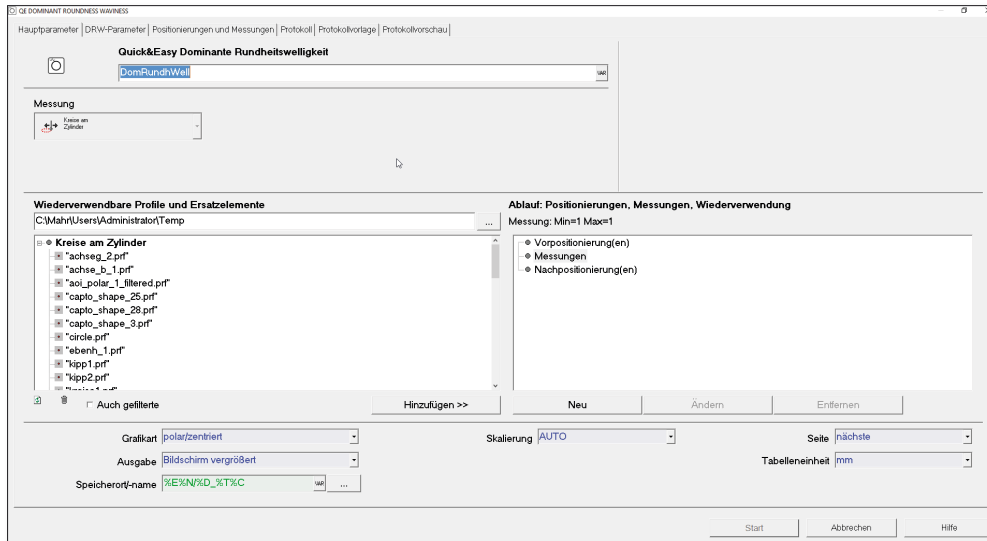

QE Dominant Roundness Waviness

The software option "Dominant Roundness Waviness" is based on the DAIMLER company standard MBN 10 455. It deals with periodically occurring waves in roundness profiles. Based on the dominant waviness analysis of profile profiles (VDA 2007), an evaluation method is described which recognizes the periodic dominant characteristics existing at the circumference, evaluates them via a roundness profile and derives parameters from them.

Furthermore, tolerance specifications are defined for this evaluation, which are easy to vary depending on the functional case.

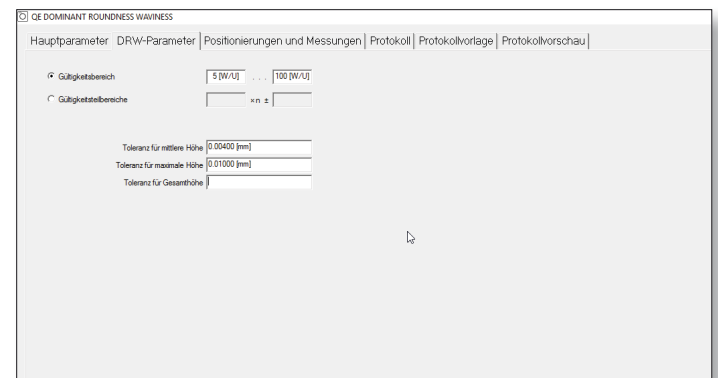

Setting Range of Validity and Tolerances

Measured value acquisition and processing

The Dominant Roundness Waviness is a software-based evaluation method that is applied to the raw data set (detected polar circumference) after a standard roundness measurement. The shorter and longer-wave components that do not belong to the dominant characteristic are eliminated by the method of the zero bandpass..

Measurement conditions:

- Number of measuring points on the circumference = 3600 points (corresponds to 0.1 ° measuring cycle)
 - Selection of the probe ball diameter according to VDI 2631-3, example:
 - Expected max. Wave depth: 5µm
 - $N = 500W / U$
 - workpiece diameter = 40mm
 - Outside probing
- max. possible probe ball diameter = 1.3mm
→ chosen: 1mm probe ball diameter

Application

The evaluation method of the Dominant Roundness Waviness is used for cylindrical components or component sections in which periodic structures in the circumferential direction lead to functional impairments. This applies above all to sealing surfaces and seating surfaces of bearings on undulating components.

Structures extending circumferentially periodically either in subregions or repeat over the entire circumference (chatter marks) are detrimental to a variety of applications. Depending on the functional case and functional partner, the effects, such as Noise or increased wear, depend on the number of structures on the circumference or a multiple thereof and on the amplitude of the structures.

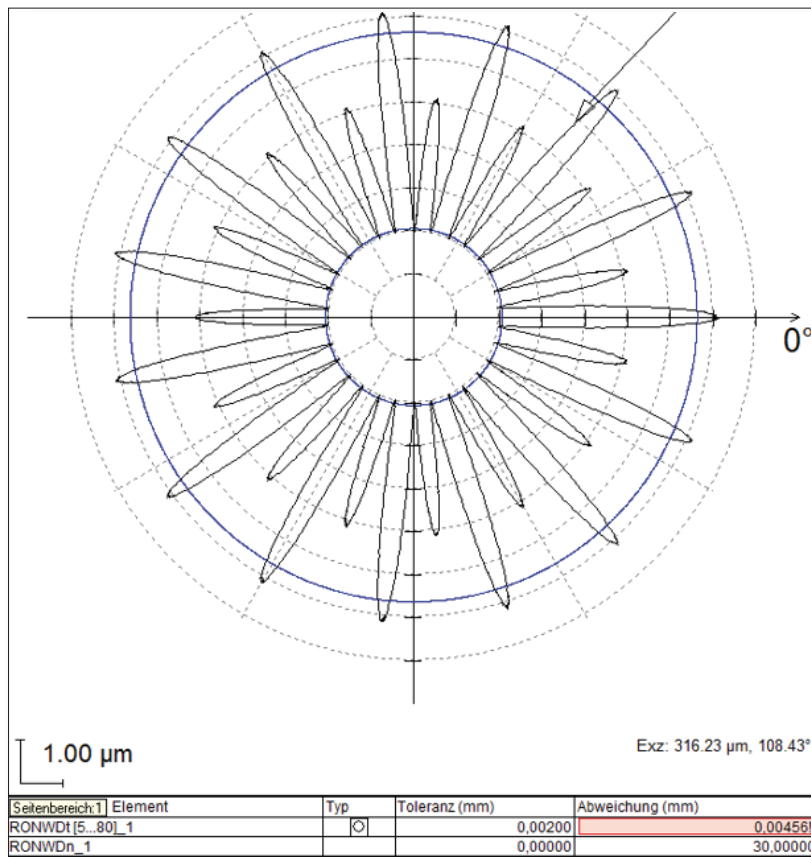

Evaluation and reporting

The basis of the recognition is the amplitude spectrum of the unfiltered roundness profile, in which each order (wave number at the circumference) is assigned a corresponding amplitude. In the amplitude spectrum, the test is for dominance of a periodic expression. This is the case if firmly defined horizontal and vertical limit criteria are met.

The characteristics of Dominant Roundness Waviness are always evaluated depending on the given validity range. The parameters are:

- RONWDc = mean height of Dominant Roundness Waviness
- RONWDt = total height of Dominant Roundness Waviness
- RONWDmax = Maximum height of the Dominant Roundness Waviness ripple
- RONWDn = number of waves of Dominant Roundness Waviness

The representation of the parameters c, RONWDt, RONWDmax in measuring reports always takes place in connection with the scope of validity. If dominance is outside the scope, it will not be used for tolerance considerations. In this case, 0D ist written in the result table.

RONWDn is always output with the integer value in the existing expression without scope.

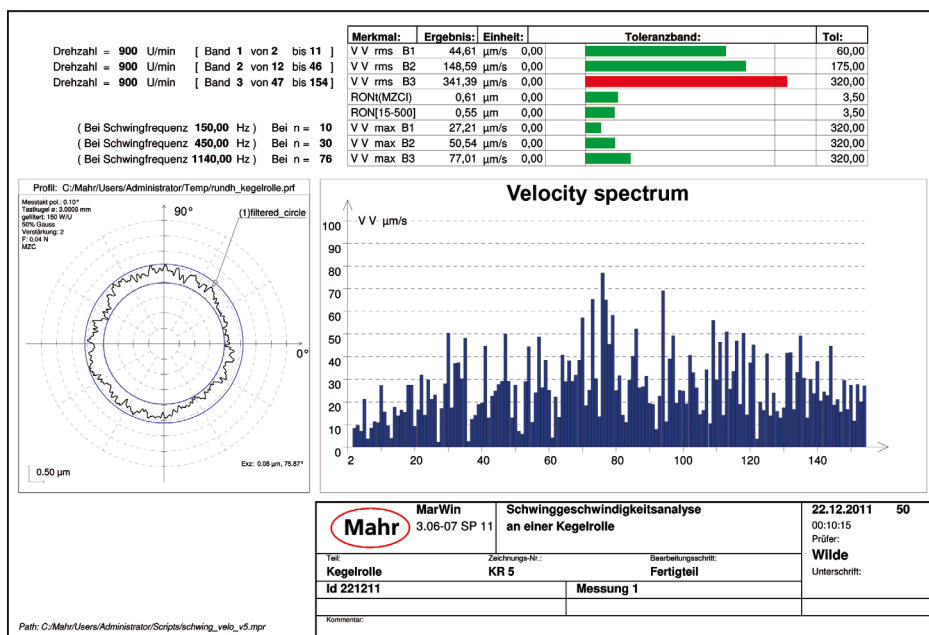

Manufactured parts for roller bearings come out of machining processes with roundness and waviness deviations from their ideal geometry. In components for high speed bearings (such as those found in computer hard disks, for example), form deviations of raceways from the ideal, smooth circle can lead to uneven running, development of noise, and reduced service life due to increased wear.

It is therefore important for the manufacturers of such bearings to have the ability to test for conformance to specified tolerances relating to the roundness deviations and waviness amplitude sizes of the individual components, preferably before the bearing is assembled. Velocity analysis is a very powerful tool in this respect, as the method permits speed-dependent, quantitative prediction and assessment of the influence and effects that any form deviations of the individual components will have on the subsequent behavior of the fully-assembled, rotating bearing.

The software can be operated with
EasyForm
AdvancedForm and
ProfessionalForm.

The velocity analysis software option is an independent analysis software that can be used with raw profiles that have been captured at an earlier time using MarForm measuring machines (fully-closed radial (axial) profiles at raceways normal to the circumferential surfaces (perpendicular to the end-faces) of the corresponding bearing components).

Before a velocity analysis can be carried out on a bearing component, it is necessary to first measure a fully-closed polar profile (full circle over 360° with no gaps) in the area of the raceway (normal to circumferential surface/perpendicular to end-face) using a MarForm measuring machine. The axis of the bearing component must first be aligned mechanically with the rotational axis of the measuring machine.

The velocity analysis software initially calculates the **Fourier amplitude spectrum** (FFT analysis) from either the complete frequency range of the unfiltered raw profile or just a user-defined frequency band of the raw profile.

Each term in this spectrum is weighted (multiplied) by the ordinal number of the term (= the number of vibration periods associated with a complete rotation of the component), by the notional rotational frequency for the term specified by the user, and by an additional fixed factor. This allows the software to calculate the **velocity spectrum** corresponding to the specification provided.

In each measuring record sheet, parameter values are calculated for three bands of the spectrum which are then output in the result table of the measuring record. The limits of each band are freely selectable and set by specifying the ordinals of the threshold spectrum terms. These parameters are the value and ordinal number with the maximum vibration speed in each band and the RMS (root mean square) 'sum' of all vibration speeds in each band. The RMS parameters serve as a measure of the vibration energy produced in the respective spectral bands during the subsequent rotational motion of the bearing components. The energy is due to the reciprocating movements induced by any radial and/or axial form deviations of the raceway.

Evaluations with up to 15 bands are easily possible in this manner.

Users can pre-configure (and freely modify at any time) complete parameter sets for five types of raceways: raceways at the generated surface of the rolling element (for balls, cylinder rollers, and cone rollers), at end face of the rolling element, at the rim of the inner bearing ring and at the circumferential surfaces of the outer and inner bearing rings.

These **parameter** sets each comprise:

- Description and band thresholds for three spectral analysis bands in the vibration speed spectrum
- Definition of a notional rotational speed for each band
- Definition of the tolerance for the sum of vibration speeds
- in each of the three bands

These memory spaces can also alternatively be used for the five most common bands.

In addition, a **cut-off wave number** can be specified, which can be used to exclude higher wave numbers of the measured raw profile prior to calculating the velocity spectrum.

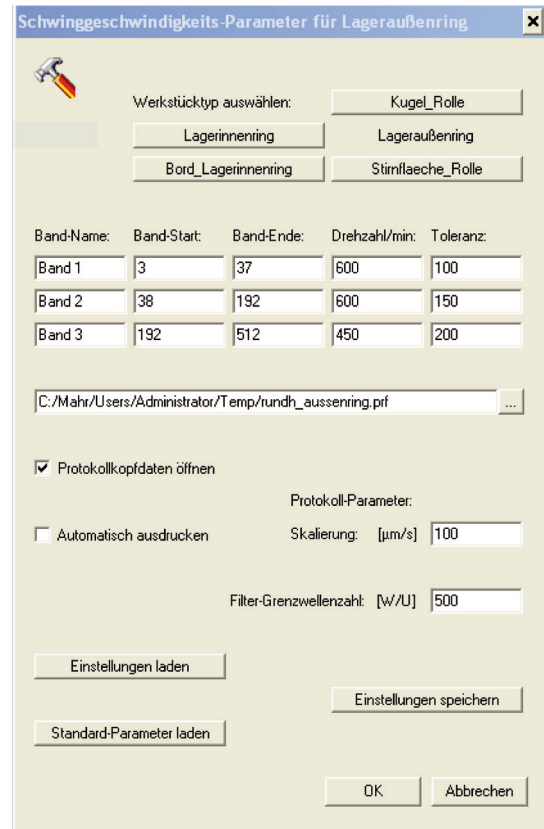

The user can also select the maximum value on the speed scale to be used when displaying the spectrum in a diagram on the measuring record.

Each of the five parameter sets configured by the user can be stored and reloaded at a later date for use in other analyses. It is possible to switch between the parameter sets for the five types of raceways at any time using the **input dialog** box displayed when the velocity analysis program is started.

A unique default dataset can also be set up by Mahr according to customer specifications for each raceway type (when the software option is first commissioned), which the user can then use to reset modified parameters back to the specified default values as necessary.

MarWin

Software Package Lead Testing and Analysis

Measured value acquisition

The surface structure of the seal face of a shaft influences the flow behavior of the fluid that is to be sealed and therefore greatly influences the sealing function.

A lead structure on the seal face can interfere with the interplay of shaft surface, fluid and sealing lip support creating leakage due to a conveying effect.

Lead is a surface feature appearing over the entire scope on rotation symmetrical surfaces. The evaluation of the macro lead is conducted with the option lead testing as per the Mercedes Benz Standard 31007-7.

Measurement of n generating lines (72 as per MB Standard, MBN 31007-7)

A probe arm for T7W, equipped with two styli, is used to record measured values:

- Stylus # 1 with HM ball dia. 3 mm for mechanical centering and tilting of the workpiece on the MMQ 400 Formtester
- Stylus # 2 with diamond stylus tip for measuring lead and form parameters

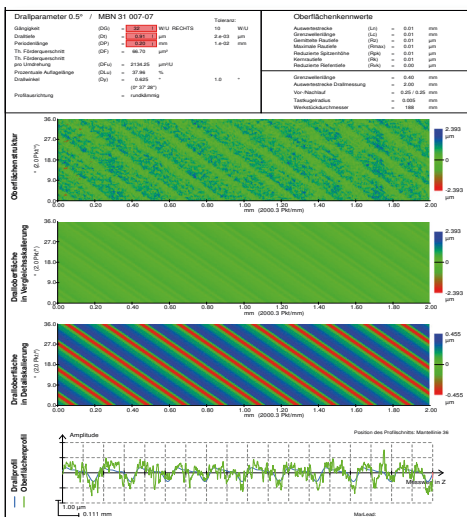
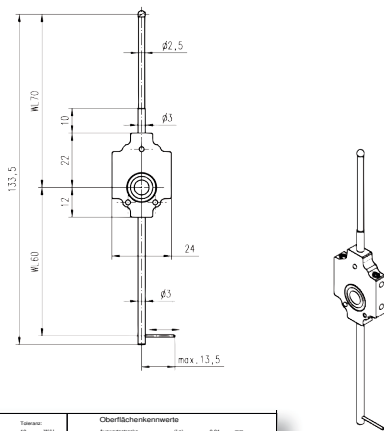

Scope of application

External measurement on workpiece diameters
dia. = 2 - 200 mm

Form and lead evaluation

- Form/positional evaluation/parallelism parallel to lead evaluation
- Form/positional/lead evaluation of several wavelengths

Evaluation and recording

After the measurements have been performed, measurement records with the following content are generated:

Lead parameters (MBN 31007-7):

The following are measured as parameters for lead evaluation:

- Number of threads DG (upr)
- Period length DP (mm)
- Lead angle D_{λ} (degree)
- Lead direction
- Lead depth Dt (μm)
- Theoretical supply cross-section DF (μm^2)
- Theoretical supply cross-section per turn DFu (μm^2)
- Contact length

Graphic output

The measured profiles are output in the record as a graphic. Various graphic output types are available:

- 3D-cylinder in color, traditional and unwound
- Display of individual generating lines as a straightness profile for individual assessment of form and position parameters
- Amplitude spectra of the linear profiles in a bar graph

or as per MBN 31007-7: 3D cylinder unwinding, color,

- Surface structure
- Lead surface
- Display of surface profile and lead profile.

Software Package Piston Measurement

Expansion package for piston measurement and evaluation

- Software package for piston-specific evaluation based on **MarWin** evaluation software
- Probe arms for piston measurement optional and customized on request

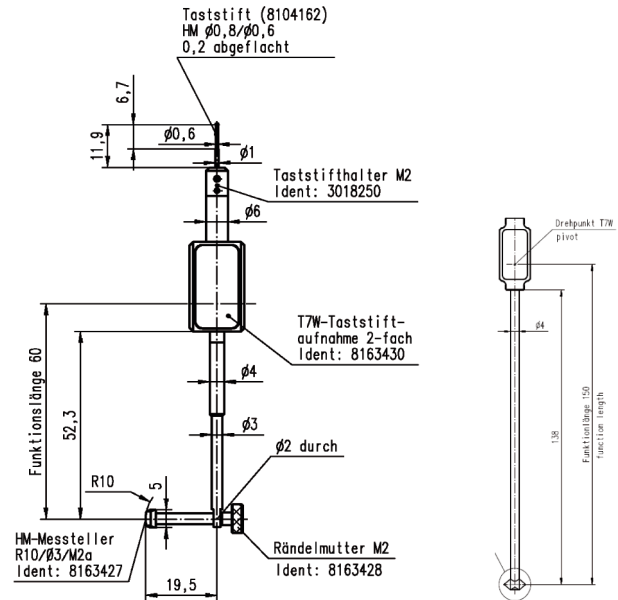

Features

Alignment of the piston

- Fully automatic and CNC alignment of the piston

Measurement on piston shape

- Measurement of the bore
- Measurement of the ovality
- Measurement of the meridian

Measurement on piston groove

Measurement of the piston pin bore shape

- Measurement of the bore shape (linear)
- Measurement of the bore shape (polar)

Evaluation piston measurement

Evaluation of the ovality

- Evaluation of the tolerance band (ovality indents) in different distances [°],
- Angle between oval main axis and bore axis in measuring height
- Determination of the head offset in X and Y (specification of the offset of the oval to piston axis)

Evaluation of the meridian

- Evaluation of the tolerance band (linear indents) in different heights [°]

Evaluation of the groove measurement

Evaluation of the radial distance

- Angle between profile and reference
- Total angle between top edge and lower edge
- Straightness of the measured radial distances

Evaluation of plane/axial circles

- Flatness of the profiles with filter 0 - 50 [W/U]
- Flatness of the profiles with filter 15 - 50 [W/U]

Evaluation of the piston pin bore

- Evaluation of the piston pin bore (linear) with evaluation of the tolerance band (linear load) in any height [mm],
- Evaluation of the piston pin bore (polar) with evaluation of the tolerance band (ovality load) in any distance [°],
- Twisting of the bore oval axis to the position of the rotary table

MarWin

Software Package Piston Measurement

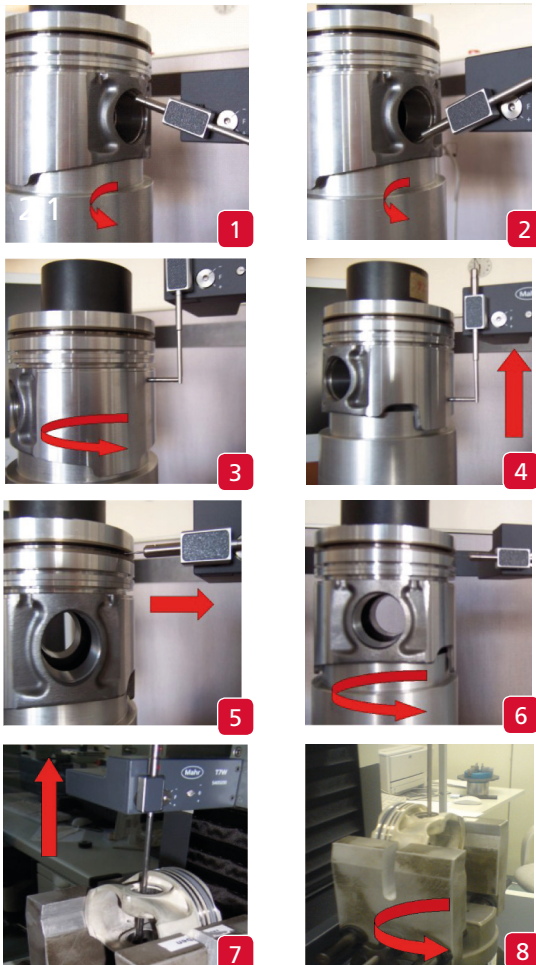

Measurement of the piston shape

- Measuring the bore**
 In order to find the angle between the oval main axis, bore axis and measuring point for meridian measurement, several reference circle measurements in the cylindrical part of the bore must be conducted (Fig. 1 and Fig. 2)
- Measuring the ovality**
 Using probe 1 and the spring axis of the form measuring machine, the measurement is conducted in 3 – 7 radial circles, in freely selectable heights of the work piece coordinate system (Fig. 3).
- Measuring in the meridian**
 In relation to the bore axis, an internal measuring point specification takes place, on which both meridian measurements can be carried out (Fig. 4).

Measurement on the piston groove

The second probe element of probe 1 measures the groove. Here the radial distances and plane circle are measured in 3 groove edges (Fig. 5 and 6).

Measuring the piston pin bore

In order to measure the form of the bore with a form measuring machine, a special clamp is needed. It must be provided by the customer. Probe 2 is needed for this measurement (Fig. 7).

Measuring the shape of the bore (linear) (Fig. 7)

Measuring the shape of the bore (polar) (Fig. 8)

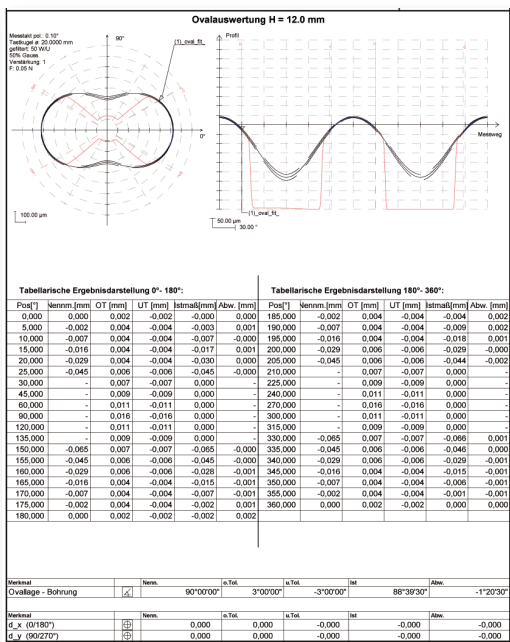

Evaluation of the piston measurement

Measurement and evaluation of the ovality and meridian measurement are conducted in a separate measuring program.

Evaluation of the ovality

- Evaluation of the tolerance band (ovality indents) in different distances [°].
- Angle between oval main axis and bore axis in measuring height.
- Determination of the head offset in X and Y (specification of the offset of the oval to piston axis).
- It is possible to print out the presentation on 2 pages if preferred. In this case, the graphic and chart are set up separately.
- A form factor can expand the graphic of the tolerance band.
- The produced and printed out measuring protocol can additionally be saved as a graphic file.

Evaluation the meridian

- Evaluation of the tolerance band (linear indents) in different heights [mm].
- It is possible to print out the presentation on 2 pages if preferred. In this case, the graphic and chart are set up separately.
- A form factor can expand the graphic of the tolerance band.
- The produced and printed out measuring protocol can additionally be saved as a graphic file.

Evaluation of the groove measurement

The groove measurement and evaluation are conducted in a separate measuring program.

Evaluation of the radial distances

- Angle between profile and reference.
- Total angle between top edge and lower edge.
- Straightness of the measured radial distances.
- It is also possible to measure and evaluate less than 3 grooves.

Evaluation of the axial circles

- Flatness of the profiles with filter 0-50 [W/U].
- Flatness of the profiles with filter 15-150 [W/U].
- It is also possible to measure and evaluate fewer than 3 grooves.

Evaluation of the piston pin bore

The measurement and evaluation of the piston pin bore is conducted in a separate measuring program.

Evaluation of the piston pin bore (linear)

- Evaluation of the tolerance band (linear load) in any height [mm].
- It is possible to print out the presentation on 2 pages if preferred. In this case, the graphic and chart are set up separately.
- A form factor can expand the graphic of the tolerance band.
- The produced and printed out measuring protocol can additionally be saved as a graphic file.

Evaluation of the piston pin bore (polar)

- Evaluation of the tolerance band (ovality load) in any distance [°].
- Twisting of the bore oval axis to the position of the rotary table.
- It is possible to print out the presentation on 2 pages if desired. In this case, the graphic and chart are set up separately.
- A form factor can expand the graphic of the tolerance band.
- The produced and printed out measuring protocol can additionally be saved as a graphic file.

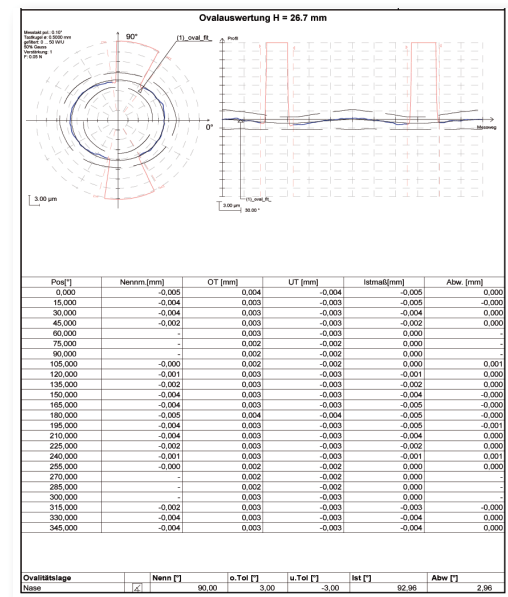
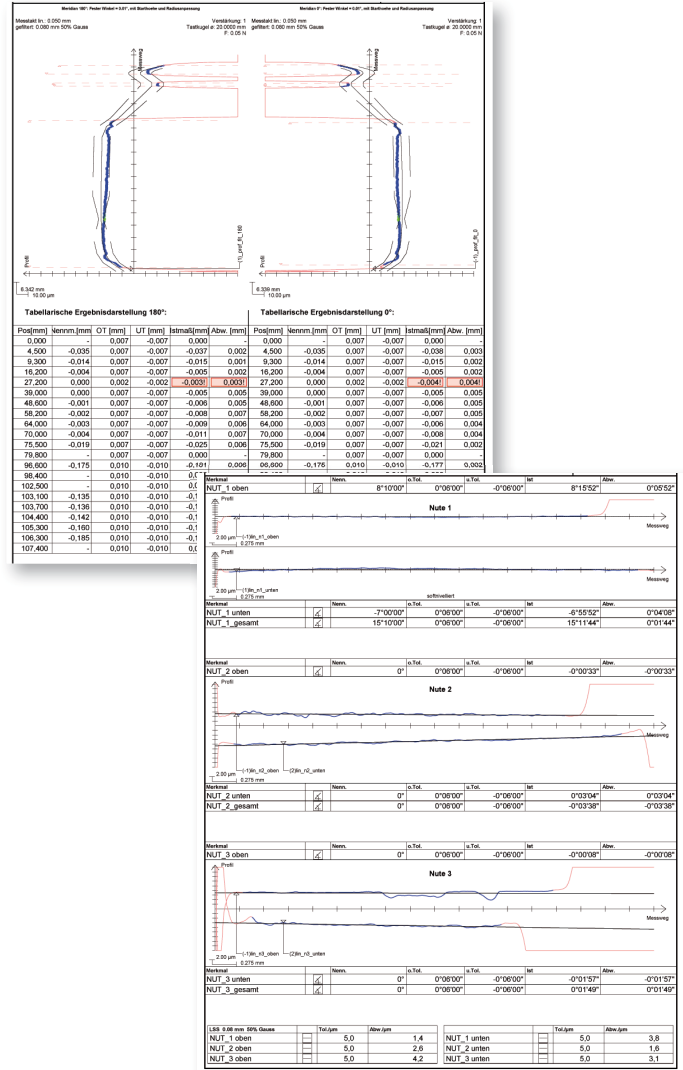

MarWin

Software Package Commutator Analysis

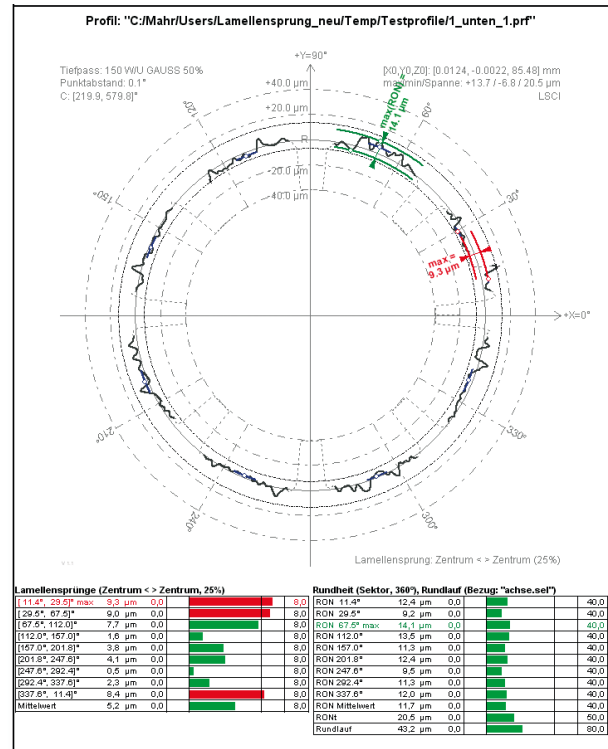

Software package for analysis of segment gap on commutators

Segment gap refers to the difference in height between the various segments on a commutator. This segment gap is a contributory factor in the wear of carbon brushes and brush fires in electric motors.

Using this software package it is possible to use MarWin analysis software with roundness measurements obtained from MarForm measuring machines in order to investigate and assess segment gaps.

Four calculation methods are provided for the evaluation of two neighboring segments (maximum segment gap):

1. Segment gap: center of segment

Difference in the radii measured at the respective centers of two neighboring segments.

The centers can optionally be expanded to ranges by entering their size as a percentage of the segment width; all radii are then averaged over this range.

2. Segment gap: max./min. radius

Difference between the respective maximum and minimum radii of two neighboring segments

3. Segment gap: difference between max. radii

Difference between the respective maximum radii of two neighboring segments

4. Segment gap: end of segment–start of segment

Difference between radii of two neighboring segments, measured at the end of one segment and the start of the next. The end and start points can optionally be expanded to ranges by entering their size as a percentage of the segment width; all radii are then averaged over this range.

The results evaluated are the values of the individual segment gaps and their mean values. The form deviations of the commutator are also recorded (individual roundnesses, corresponding mean value, overall roundness), as is the radial run-out.

Measuring Strategies

— Straightness, including by section

1 ... n
Measurement Z ↔

1 ... n
Measurement X ↔

3 ... n
Measurement C ↔

▭ Flatness

1 ... n
Measurement C ↔

⊘ Cylindricity

2 ... n
Measurement C ↔

Measurement C+Z ↔
(3D helix)

3 ... n
Measurement Z ↔

○ Roundness

1 ... n
Measurement C ↔

// Parallelism

1 ... n
Measurement Z ↔
Datum: Axis

1 ... n
Measurement Z ↔
Datum: Measurement Z ↔

Measurement X ↔
Datum: Measurement X ↔

Measurement X ↔
Datum: Measurement ↔

Measurement C ↔
Datum: Axis

Measurement C ↔
Datum: Measurement Z ↔

Measurement C ↔
Datum: Measurement C ↔

⊥ Perpendicularity

Measurement Z ↔ Datum: Measurement X

Measurement Z ↔ Datum: Measurement C

Measurement X ↔ Datum: Axis

Measurement X ↔ Datum: Measurement Z

Measurement X ↔ Datum: Measurement C

Measurement X ↔ Datum: Measurement C

Measurement C ↔ Datum: Measurement Z

Measurement C ↔ Datum: Measurement C

Measurement C ↔ (Cylinder axis) Datum: Measurement C

∠ Angularity

Measurement Z ↔ Datum: Measurement X

Measurement Z ↔ Datum: Measurement C

Measurement X ↔ Datum: Measurement Z or Datum: Axis

Measurement X ↔ Datum: Measurement X

Measurement X ↔ Datum: Measurement C

Measurement C ↔ Datum: Measurement Z or Datum: Axis

Measurement C ↔ Datum: Measurement X

Measurement C ↔ Datum: Measurement C

Measurement Z ↔ Datum: Measurement Z or Datum: Axis

Run-out

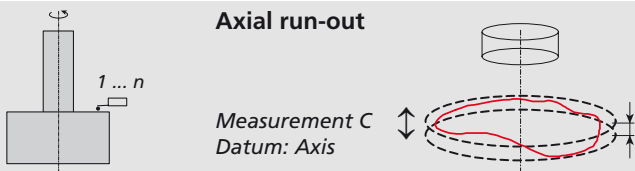
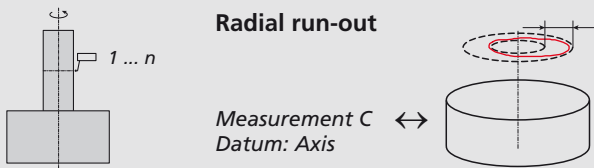

Total run-out

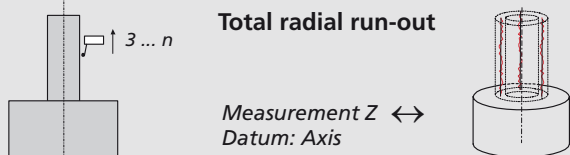
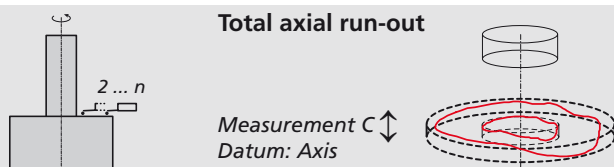
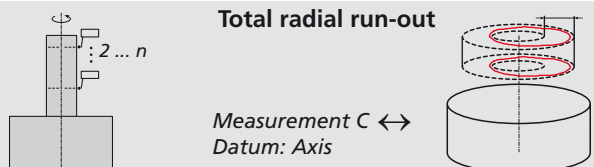

Conicity

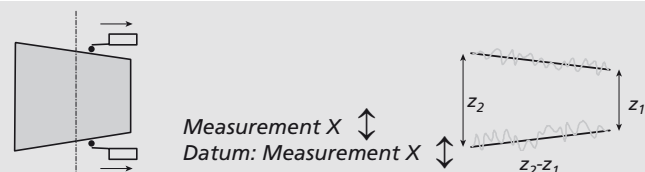
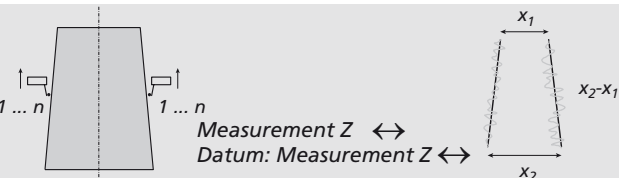
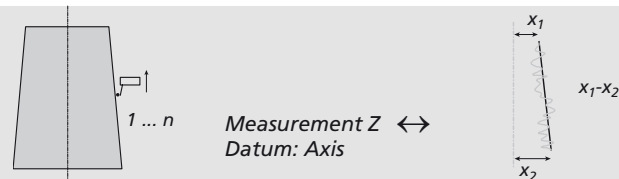

Concentricity and coaxiality

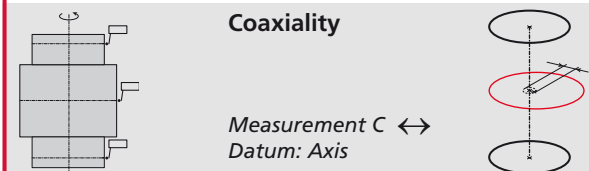
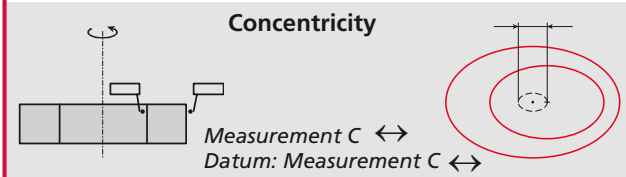

Cone form

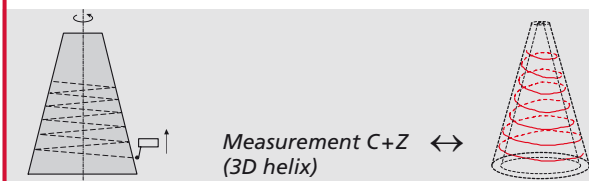
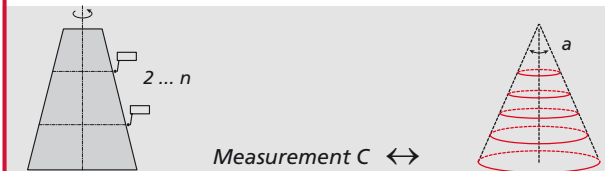

Angle sector

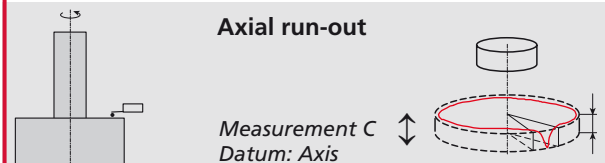
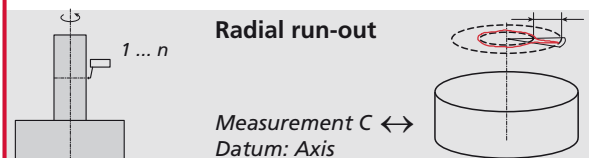
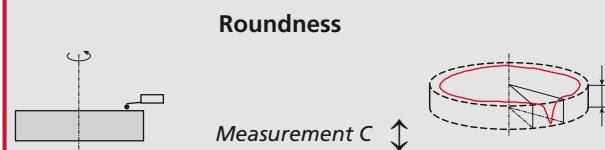
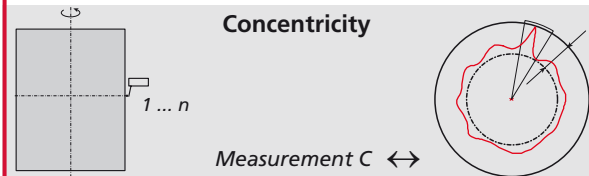

Note: Measurement with 3D helix optimal

MarForm

Accessories Probe

The optimal solution using accessories

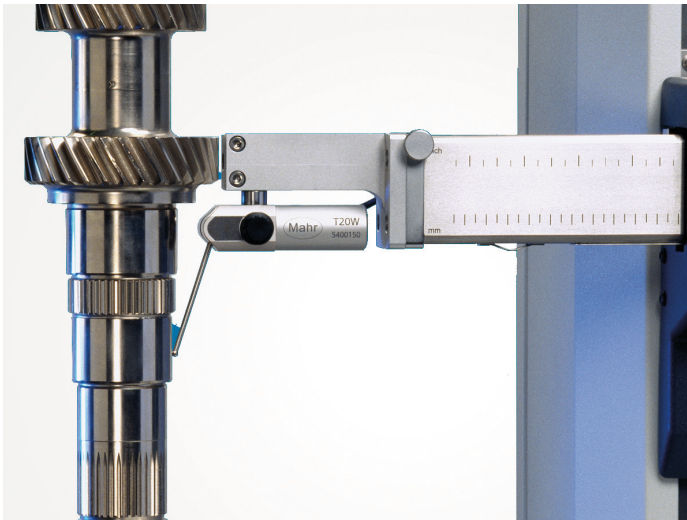

T20W Probe

The inductive **T20W** probe is a universal device. The fact that the probe arm can be moved in a range of 190° and that there are a variety of clamping options for the probe means that measurements can also be performed in areas that are difficult to access. Easily exchangeable probe arms can be combined with a variety of styli in order to adapt the probe to the relevant measuring tasks or workpieces.

T20W probe with probe arm range of 190°

- Measuring range $\pm 1,000 \mu\text{m}$
- Measuring force adjustable up to 0.15 N
- Measuring direction switchable
- Exchangeable probe arm
- Free travel limitation can be adjusted in contacting direction
- Clamping shaft dia. 8 mm (0.315")

Order No. 5400151 for MMQ 400

Probe arms for T20W probes

Probe arm 60 mm, ball dia. 1.0; M2 longitudinal	5400161
Probe arm 60 mm, ball dia. 3.0	5400160
Probe arm 60 mm, ball dia. 1.0; M2 transverse	5400163
Probe arm 60 mm, ball dia. 1.0; M2 longitudinal; shaft dia. 0.8 L=30 mm	5400170
Probe arm 120 mm, ball dia. 1.0; M2 longitudinal	5400162
Probe arm 120 mm, ball dia. 1.0; M2 transverse	5400164
Probe arm 160 mm, ball dia. 1.0; M2 transverse CFK	5400165
Probe arm 200 mm, ball dia. 1.0; M2 transverse CFK	5400166
Probe arm 250 mm, ball dia. 1.0; M2 transverse CFK	5400167

Multi-point probe arm kit for T20W

Basis for multiple probe arms; with one probe arm holder, two vertical probe arms and one horizontal probe arm, as well as two styli: 1 ruby stylus of L=10 mm and dia. 1.0 mm and 1 ruby stylus of L=20 mm and dia. 1.0 mm

400168

Styli M2

Stylus Teflon dia. 3 mm, M2	5400169
Stylus L=10 mm, ball dia. 0.3 mm ruby	4662093
Stylus L=10 mm, ball dia. 0.5 mm ruby	4662090
Stylus L=10 mm, ball dia. 1.0 mm ruby	3016272
Stylus L=10 mm, ball dia. 1.5 mm ruby	8154125
Stylus L=10 mm, ball dia. 3.0 mm ruby	8154398
Stylus L=20 mm, ball dia. 5.0 mm ruby	8159402
Stylus L=10 mm, ball dia. 1.0 mm carbide	8162168
Stylus L=10 mm, ball dia. 1.5 mm carbide	8049415
Stylus L=10 mm, ball dia. 2.0 mm carbide	8162164
Stylus L=10 mm, ball dia. 3.0 mm carbide	8159618
Stylus L=20 mm, ball dia. 5.0 mm carbide	8049416
Wrench for stylus arms/styli	5440192

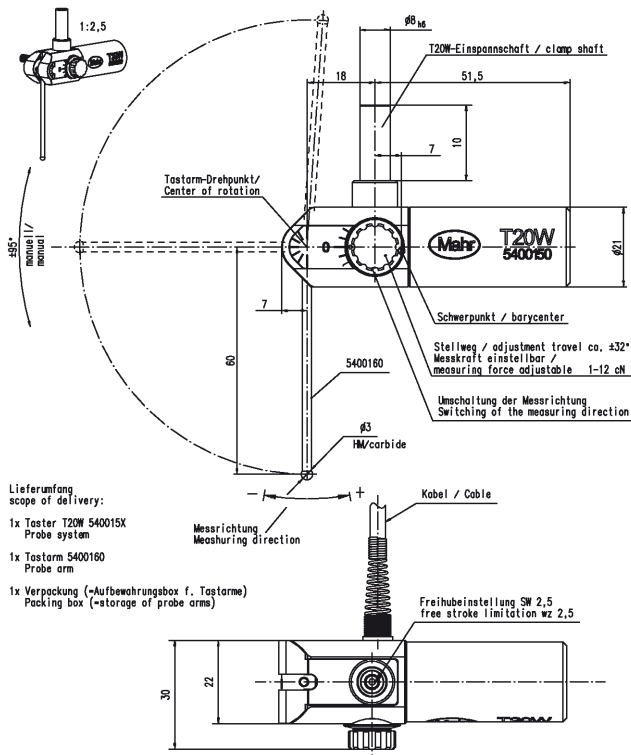

Probe Arms for T20W Probe

Ident-Nr.: 5400160

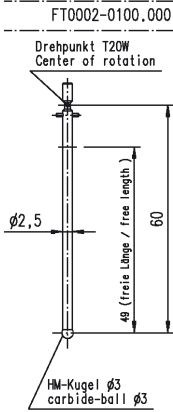

Ident-Nr.: 5400161

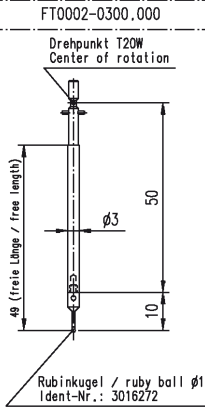

Ident-Nr.: 5400162

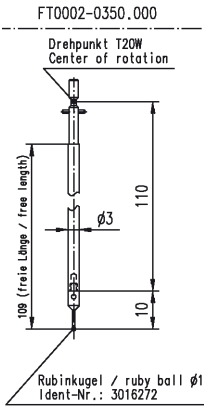

Ident-Nr.: 5400170

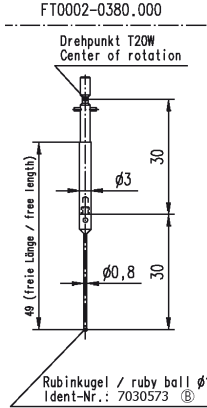

Ident-Nr.: 5400163

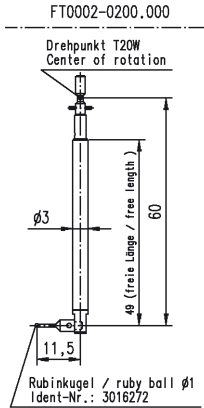

Ident-Nr.: 5400164

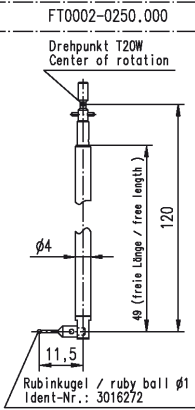

Ident-Nr.: 5400169

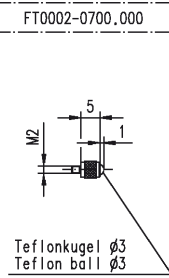

Ident-Nr.: 5400165

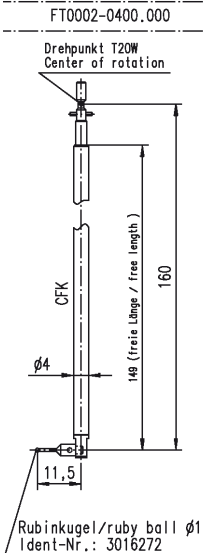

Ident-Nr.: 5400166

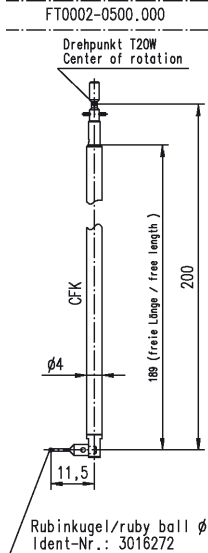

Ident-Nr.: 5400167

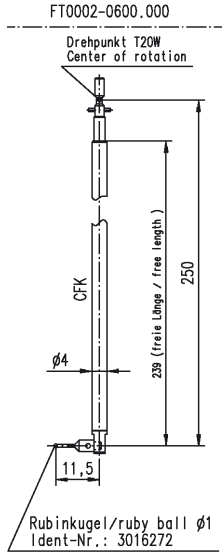

Stylus arms/styli M2

Ident-Nr.	Kugel- ϕ [mm] ball- ϕ [mm]	Material	Wirklänge [mm] operation length [mm]
4662093	0,3	Rubin/ruby	10
4662090	0,5	Rubin/ruby	10
3016272	1,0	Rubin/ruby	10
8156089	1,0	Rubin/ruby	20
8154125	1,5	Rubin/ruby	10
8154398	3,0	Rubin/ruby	10
8159402	5,0	Rubin/ruby	20
8162168	1,0	HM/carbide	10
8049415	1,5	HM/carbide	10
8162164	2,0	HM/carbide	10
8159618	3,0	HM/carbide	20
8049416	5,0	HM/carbide	20

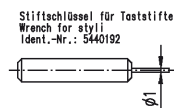

Ident-Nr.: 5400168

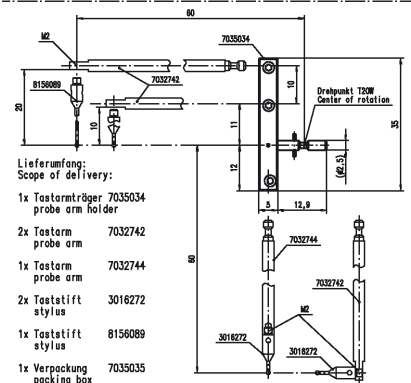

- Lieferumfang:
Scope of delivery:
- 1x Testarmträger 7035034 probe arm holder
 - 2x Testarm 7032742 probe arm
 - 1x Testarm 7032744 probe arm
 - 2x Teststift 3016272 stylus
 - 1x Teststift 8156089 stylus
 - 1x Verpackung 7035035 packing box

MarForm

ACCESSORIES FOR PROBE

The optimal solution using accessories

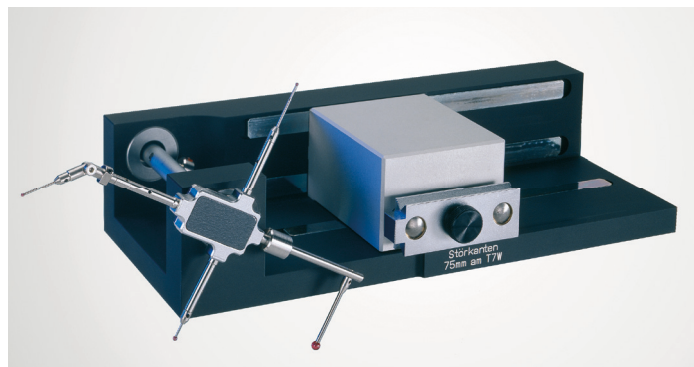

Device for balancing probe arms



Motor-driven T7W Probe

The T7W probe is fitted with a motor-driven rotational axis. This makes it possible to move the probe arm gradually to the required contacting position. As a result, measurements can be performed on cylindrical surfaces and end faces. As a zero position probe, the T7W can also switch automatically between internal and external measurements or between end face measurements from above and below without operator intervention. Fully automatic measurement processes on complex workpieces can be carried out without operator intervention too. The probe arms of the T7W are exchangeable. Its motor-driven rotational axis enables the construction of "multi-point probe arms" - i.e. probe arms with a variety of contacting elements - making it possible to switch between different stylus ball geometries within a single measurement run.

Motor-driven T7W probe with probe arm range of 360° for MMQ 400 and MMQ 400 CNC Order No. 5400200

- Total meas. range of 2,000 μm (0.079")
- Zero probe with a working range of $\pm 500 \mu\text{m}$ ($\pm 0.0197''$)
- Measuring force adjustable from 0.01 to 0.2 N
- Two-way measuring direction
- Contacting angle freely selectable in 1° steps
- 360° adjustable (motor-driven)
- Probe arms easily exchangeable (magnetic mount)
- Flexible multi-point probe possible
- Mechanical and electrical overload protection

Accessories for Motor-driven T7W Probe

Probe arm module for T7W Order No. 5400221

In storage case, consisting of

- Stylus arm dia. 0.5 mm, L=20 mm, M2a
- Stylus arm dia. 1.0 mm, L=20 mm, M2a
- Stylus arm dia. 1.0 mm, L=15 mm, M2a
- Stylus arm dia. 1.5 mm, L=10 mm, M2a
- Stylus arm dia. 3.0 mm, L=10 mm, M2a
- Stylus arm dia. 3.0 mm, L=25 mm, M2a
- Weight 1.5 g
- Weight 1.0 g
- Weight 2.0 g
- Weight 3.0 g
- Weight 0.5 g
- Weight 10.0 g
- Weight 5.0 g
- Probe arm L=15 mm 2x M2
- Stylus arm extension 10 mm, M2
- Stylus arm extension 20 mm, M2
- Stylus arm extension 30 mm, M2
- Stylus arm extension 40 mm, M2
- Rotary swivel joint M2
- Hex head screwdriver A/F 1.5
- Hex head screwdriver A/F 0.9
- Rotary part M2, concentric
- Wrench 1.0
- Stylus arm holder M2i transverse
- Stylus arm holder M2i axial
- Stylus M2i transverse
- Mount 2x M2i transverse
- Guide
- Adjuster

Probe Arm for T7W Probe

Probe arm set for T7W

Consisting of one each of probe arms 5400225, 5400226, 5400229 and 5400230

Order No. 5400211

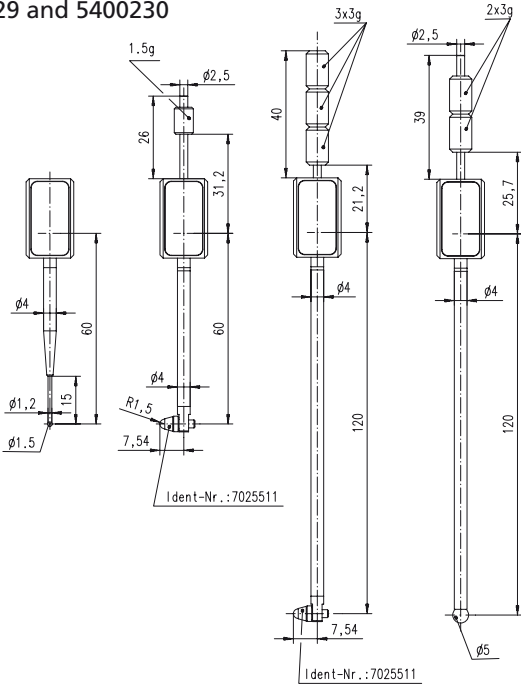

Probe arm set # 2 for T7W

for measuring small workpieces, consisting of a probe arm holder and three exchangeable M2 styli

Order No. 5400220

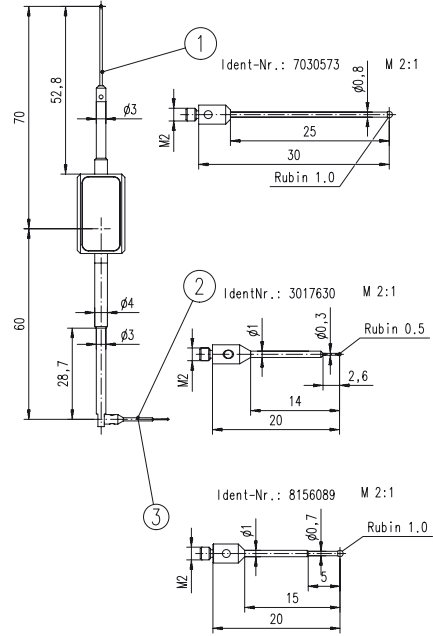

Probe arm module for T7W

for universal measurement of various workpieces.

Order No. 5400221

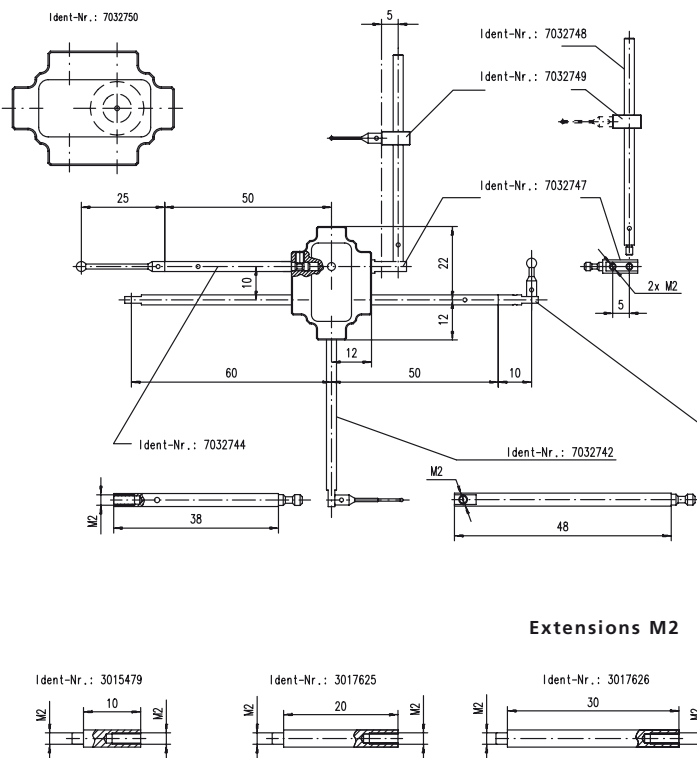

Stylus arms M2

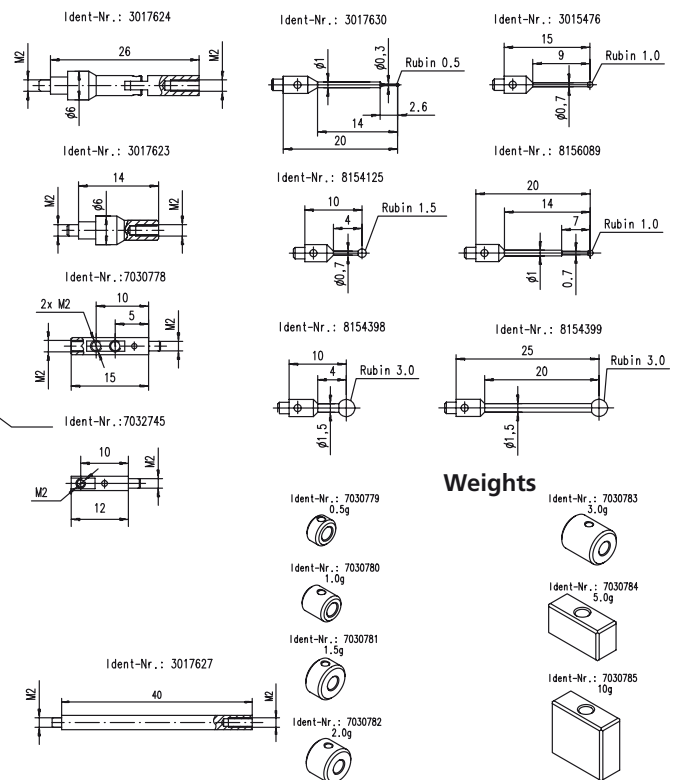

Weights

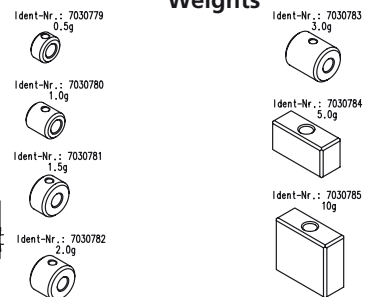

MarForm ACCESSORIES

Clamping and Chucking Devices



Three-jaw chuck, dia. 100 mm with mounting flange of dia. 160 mm, reversible jaws for external and internal clamping. Clamping range: external 1 to 100 mm, internal 36 to 90 mm. Total height with flange 47 mm. Adjustment by means of rotating ring.

Order No. 6710620

Rim chuck with 8 jaws, dia. 150 mm with mounting flange of dia. 198 mm; separate jaws for internal and external clamping. Clamping range: external 1 to 152 mm, internal 24 to 155 mm.

Total height with flange 52 mm. Cannot be used for Formtester MMQ 10/ MMQ 100. Adjustment by means of rotating ring.

Order No. 6710518

Three-jaw chuck, dia. 110 mm with mounting flange of dia. 164 mm; clamping range: external 3 to 100 mm, internal 27 to 100 mm.

Total height with flange 73 mm (2.87").

Adjustment by means of rotating ring.

Order No. 6710629

Three-jaw chuck, dia. 80 mm with mounting flange of dia. 124 mm; clamping range: external 2 to 78 mm, internal 26 to 80 mm. Total height with flange 65.5 mm.

Adjustment by means of T-wrench.

Order No. 9032206



For collet chucks: Type 407 E

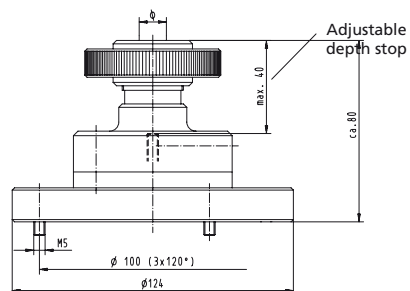

Quick-clamping device (collet chuck)

Dia. 1 to 12 mm with mounting flange of dia. 124 mm, for external clamping.

Supplied with collet chucks of dia. 1 mm to 8 mm in 0.5 mm steps. Total height 80 mm.

Further collet chuck devices are available on request.

For collet chucks: Type 444 E

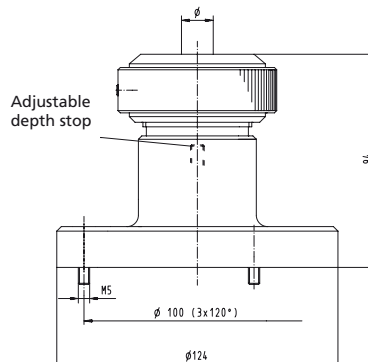

Quick-clamping device (collet chuck)

Dia. 2 to 25 mm with mounting flange of dia. 124 mm, for external clamping. Supplied with stand but no collet chucks.

Total height 94 mm.

Further collet chuck devices are available on request.

Clamping disks

Clamping disk set. Adjustable workpiece stop for pre-centering and clamping in series measurements. For clamping diameters of 36 mm to 232 mm depending on machine type. Comprises two stop disks with slot and an eccentric clamping disk.

Order No. 6850808

Clamping jaws 2x

With M5 fastening thread. Clamping height 40 mm.

Order No. 6710628

Further workpiece-specific clamps are available on request.

Equipment Tables and Other Accessories



Equipment Table for MarForm MMQ 400

Size: 1,150 mm x 750 mm x 720 mm (L x W x H)
We recommend using work table 5440708 in addition to this equipment table (see photo on the bottom left)

Order No. 5440701

Work table for MMQ 400

Size: 1,200 mm x 800 mm x 720 mm (L x W x H)
with mount for PC unit.
For use in addition to equipment table 5440701 or 5440707 (shown in photo on the bottom right)

Order no. 5440708

(Photo shows options)



Enclosure for MarForm MMQ 400

(MMQ 400 Type A with Z = 350 mm and Type B with Z = 500 mm)
as a standing workstation with integrated touch screen monitor with regulated, pneumatic vibration isolation system

Order No. 5440302

Equipment table for MMQ 400

Size: (L x W x H)
1000 mm x 800 mm x 700 mm
with passive controlled anti-vibration system and granite plate
total weight 450 kg
air connection G1/4
app. 10 l/min. consumption

Order No. 9049028



We recommend using work table 5440708 in addition to this equipment table.

MarForm

Testing and Calibration Standards

Roundness Standard

High-precision glass hemisphere

Testing of the measuring spindle's radial run-out accuracy.
Calibrating the sensitivity of the signal transmission chain.
For testing the radial deviation of the rotational guide (C-axis).

Diameter	approx. 55 mm (2.165 in)
Roundness deviation	max. 0.04 μm (1.57 μin)
Weight	approx. 1.8 kg (3.968 lbs)

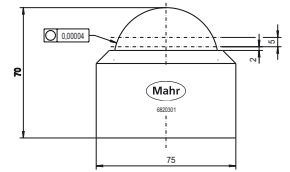

Roundness standard

without calibration certificate
DAkKS/DKD calibration certificate incl.
Mahr calibration certificate incl.

Order no. 6820300
Order no. 9964115
Order no. 9964307

Ceramic Roundness Standard

High-precision calibration ball

Testing of the measuring spindle's radial run-out accuracy.
Calibrating the sensitivity of the signal transmission chain.
For testing the radial deviation of the rotational guide (C-axis).

Diameter	approx. 13 mm (2.165 in)
Roundness deviation	max. 0.05 μm (1.97 μin)

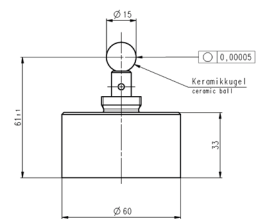

Roundness standard

without calibration certificate
DAkKS/DKD calibration certificate incl.
Mahr calibration certificate

Order no. 5400013
Order no. 9964115
Order no. 9964307

Magnification Standard

Cylinder with one slightly flattened section (Flick)
For checking the signal amplification.

Diameter	20 mm (.787 in)
Length	50 mm (1.969 in)
Flattening	approx. 10 μm (393.7 μin)
Cylindricity deviation	max. 1 μm (39.37 μin)
Weight	approx. 0.4 kg (.882 lbs)

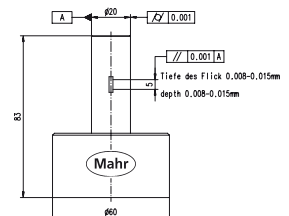
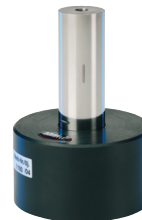

Magnification Standard

without calibration certificate
DAkKS/DKD calibration certificate
Mahr calibration certificate

Order no. 5400147
Order no. 9964148
Order no. 9964311

Universal Cylinder Square

High-precision cylinder square
With two flattened sections (Flicks).
For checking the vertical guide.
Two surfaces for calibrating the signal transmission chain
and testing the measuring constancy.
Calibrating the sensitivity of the signal transmission chain.
For testing the straightness and parallelism of the axes.

Diameter	20 mm (.787 in)
Length	150 mm (5.906 in)
Flattening	approx. 4/12 μm (157.48/472.44 μin)
Roundness deviation (cyl.)	max. 0.2 μm (7.87 μin)
Straightness deviation (cyl.)	max. 0.2 μm (7.87 μin)
Parallelism deviation (cyl.)	max. 0.2 μm (7.87 μin)
Weight	approx. 0.4 kg (.882 bs)

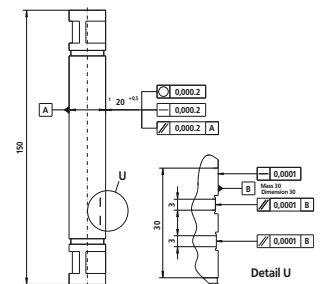

High-precision cylinder square

DAkKS/DKD calibration certificate incl.
Mahr Calibration certificate incl.

Order no. 5400143
Order no. 5400140

Flatness Standard - optical flat



Testing and adjusting the horizontal measuring device.
Testing the axial deviation of the rotational guide.
Testing the straightness of the linear guide.



Optical flat

without calibration certificate
DAkks/DKD calibration certificate incl.
Mahr calibration certificate incl.

Order no. 6820210
Order no. 9964321
Order no. 9964310

Diameter	150 mm (5.906 in)
Flatness deviation	0.2 μm (7.87 μin)
Weight	approx. 2 kg (4.409 lbs)

Multi-Wave Standard



Dynamic testing of the signal amplification.
Calibrating the sensitivity of the signal transmission chain.
Calibrating the vertical and horizontal profile components.
Testing of filters / Fourier analysis.

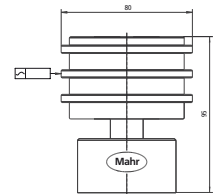
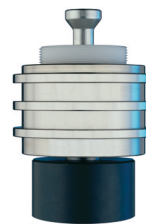

Multi-Wave Standard

without calibration certificate
DAkks/DKD calibration certificate
Mahr Calibration certificate

Order no. 5400142
Order no. 9964149
Order no. 9964312

Diameter	80 mm (3.150 in)
Sinusoidal waves on the outside diameter	15, 50, 150, 500 upr
Weight approx.	2.3 kg (5.071 lb)

Straightness Standards - Cylinder Squares



Testing and adjusting the vertical guide relative to the measuring spindle axis. For testing the straightness of the linear guides.
For testing the parallelism.

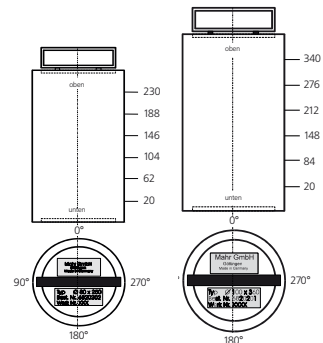

Cylinder square

Type 1: 80 mm

DAkks/DKD Calibration certificate incl.
Mahr-Calibration certificate incl.

Order no. 6820204
Order no. 6820202

Type 2: 100 mm

DAkks/DKD-Calibration certificate incl.
inkl. Mahr-Calibration certificate incl.

Order no. 6820206
Order no. 6820201

Type 1: 80 mm cylinder square	
Diameter	80 mm (3.150 in)
Length	250 mm (9.843 in)
Cylindricity deviation	max. 1 μm (39.37 μin)
Roundness deviation	< 0.7 μm (27.56 μin)
Weight	approx. 11.5 kg (25.353 lbs)

Type 2: 100 mm cylinder square	
Diameter	100 mm (3.937 in)
Length	360 mm (14.173 in)
Cylindricity deviation	max. 1 μm (39.37 μin)
Roundness deviation	< 0.7 μm (27.56 μin)
Weight	approx. 13 kg (28.660 lbs)

Customer Master

For testing, adjusting and calibrating the measuring device without conversion work. You can use your own test items/workpieces as the master/standard, provided these have been issued with a calibration certificate by the Mahr calibration laboratory.

Customer Master

DAkks/DKD Calibration certificate incl.
Mahr-Calibration certificate incl.

Order no. 9964313
Order no. 9964314

* German Calibration Service

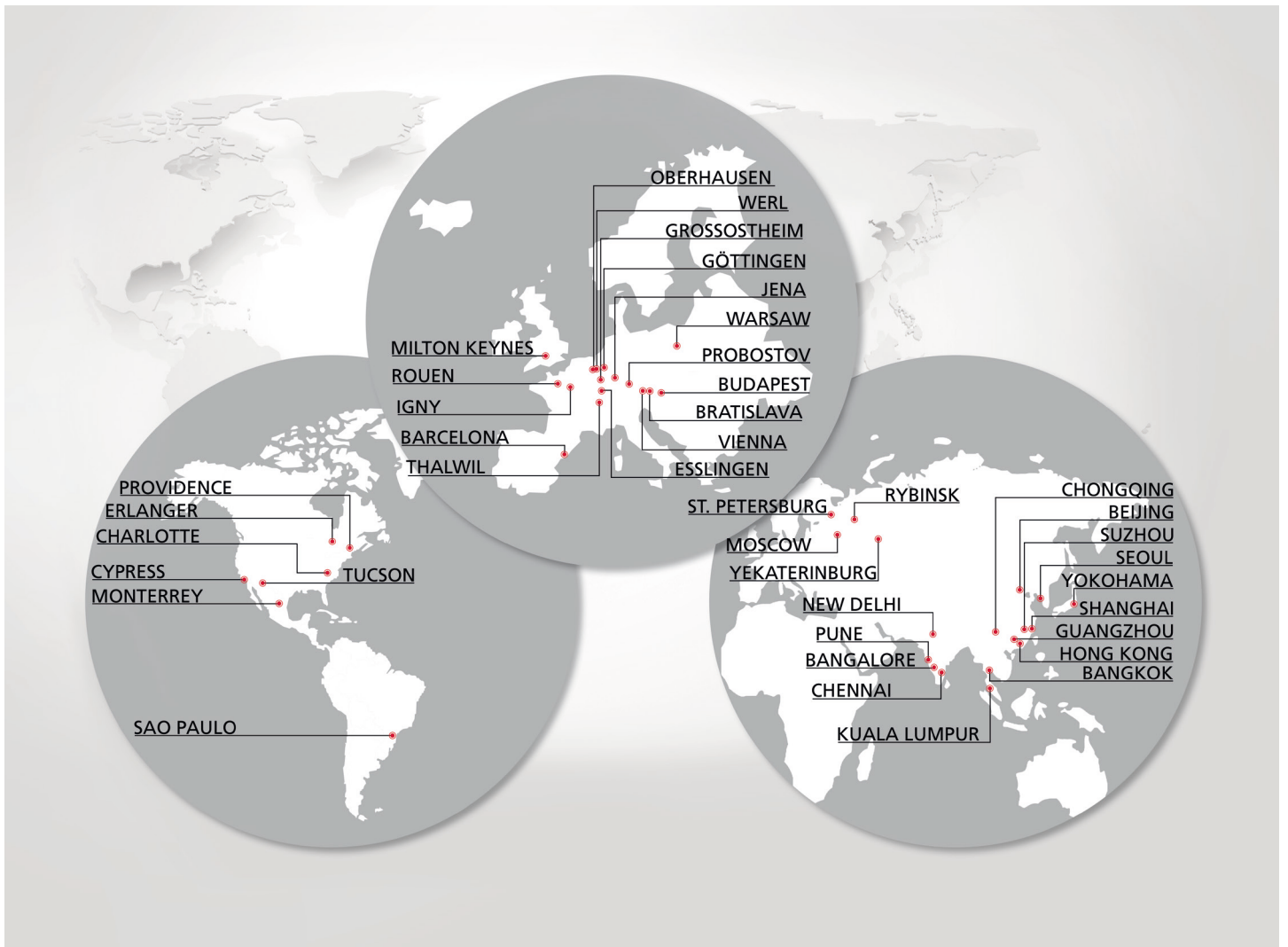

Partner for manufacturing companies worldwide.

Close to our customers.

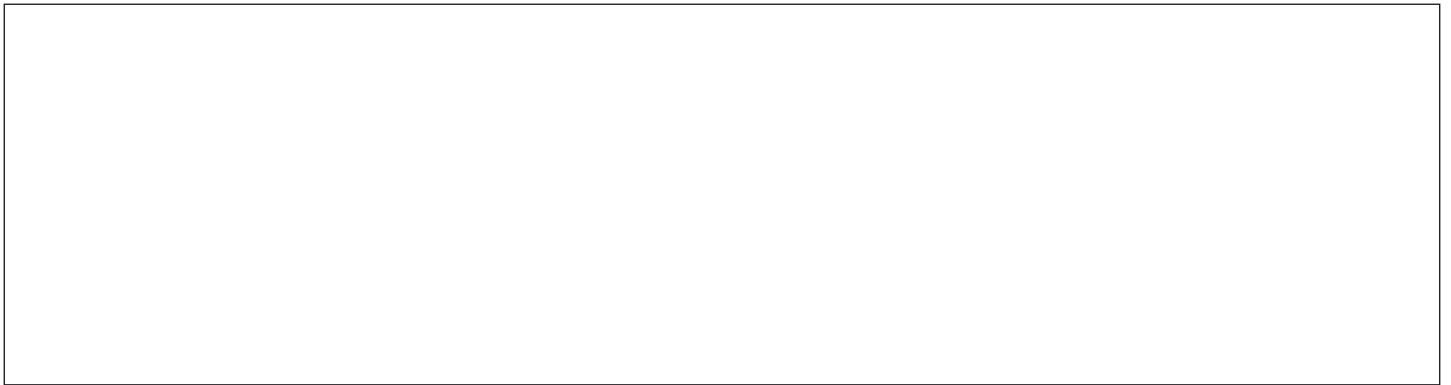

- 0 +



Mahr GmbH
 Carl-Mahr-Straße 1, 37073 Göttingen
 Reutlinger Str. 48, 73728 Esslingen
 Phone +49 551 7073-800, Fax +49 551 7073-888



© Mahr GmbH
 We reserve the right to perform modifications to our products, particularly technical improvements and further developments. Illustrations and numerical data are therefore not binding.

E X A C T L Y

info@mahr.de, www.mahr.de

3760593 | 04.2019