



KANOMAX
The Ultimate Measurements

CAPTURE HOOD

MODEL 6715

INSTRUCTION MANUAL



Be sure to read this manual thoroughly before using the instrument ,
fully understand and pay attention to each cautions mentioned.

Please well-keeping this manual for long time service reference.



01001

14.07

CONTENTS

Product Configuration	3
Caution	4
1. Introduction	6
1.1. Features	6
1.2. Specifications	6
2. Outlook & Structure	7
2.1. Base structure	7
2.2. Micromanometer	8
3. Set tubg up	8
3.1. Capture Hood	8
3.2. Velocity Matrix	9
3.3. Pitot tube	9
3.4. Micromanometer testing	10
3.5. Shoulder Strap	10
4. Operating Instruction	10
4.1. Power supply	10
4.2. Start On / Power Off	11
4.3. Keypad operation	11
5. Function test	13
5.1. User Interface	13
5.2. Single Mode	13
5.3. Average Mode	14
5.4. Back Pressure Mode	14
6. Menu setting	15
6.1. Basic setting	15
6.1.1. Date	15
6.1.2. Time	15
6.1.3. Units	16
6.1.4. Auto Off	16
6.1.5. Backlighting	16
6.1.6. Communication	17

6.1.7. Tools	18
6.2. Test setting	18
6.2.1. ID application	18
6.2.2. Test Mode	18
6.2.3. Data record	19
6.2.4. Standard/Actual test	20
6.2.5. Compensation factor	20
7 Error and Troubleshooting	21
8 Warranty and Service	22
8.1. Product Warranty	22
8.2. After service	22

Product Configuration.

Standard:

Model	Functions
6715	Measuring: Air volume/ velocity/ differential pressure/ temperature/ humidity/ absolute pressure

Accessories:

Item.	Qt'y
Micromanometer 6715-DP	1
Instrument Base	1
Fabric Hood: 2ftx2ft	1
Carrying case	1
Portable handle	1
Frames	1
Poles	4
Communication cable	1
CD-Rom (Manual and software inside)	1
Quick-Guide	1

Optional Parts:

Items.	Specifications
Pitot kits : 6715-PT	
Velocity Matrix kits: 6715-MX	
Shoulder Strap	
Communication cable	
Printer	
AC Adapter	DC5V
Power plug	
Tri-pod Stand	Up to 3.5m with capture hood
Carrying case	
Fabric Hood	2ftx4ft
	1ftx4ft
	3ftx2ft
	3ftx3ft

Caution.

The symbols for warning mentioned in this manual are defined below:

(symbols classifications)

 **Danger:** To Prevent Serious Injury or Death

Warnings in this classification indicate a danger that may result in serious injury or death if not observed.

 **Caution:** To Prevent Damage to the Product

Warnings in this classification indicate a risk of damage to the product that may void the product warranty if not observed.

(Description of Symbols)









△ This symbol indicates a condition that requires caution (including danger). The subject of each caution is illustrated inside the triangle .



⊘ This symbol indicates a prohibition. Do not take the prohibited action shown inside or near this symbol.

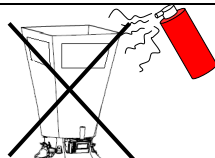

● This symbol indicates a mandatory action. A specific action is given near the symbol.

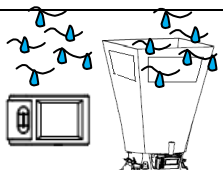
 WARNING		
 Heated forbidden	<ul style="list-style-type: none"> ○ Never bring the fabric hood to a flammable gas atmosphere. ... otherwise, the heat may cause a fire or explosion. 	
 Disassemble prohibition	<ul style="list-style-type: none"> ○ Do not disassembly or refit the instrument. ... otherwise, may cause the electric shock or a fire. 	
 Using properly	<ul style="list-style-type: none"> ○ Using properly under the instruction manual. ... otherwise, may cause sensor damaged or an electric shock even a fire. 	
 Using properly	<ul style="list-style-type: none"> ○ If abnormal smells, noises or smoke occur, or if liquid enters the instrument, pull out the AC adapter and remove the batteries immediately. Then send it to the maintenance Dept. of KANOMAX for after service. ... or, there is possible of an electric shock or a fire or instrument malfunction. 	
 Forbidden	<ul style="list-style-type: none"> ○ Do not expose the fabric hood, base and the instrument nomenon in the rain. ... otherwise, may cause an electric shock, an fire and an person injure. 	

 **CAUTION**



Using properly

- Always unplug when the instrument not in use.
- … Failure to do so may cause an electric shock, an fire or circuit damage.



Using properly

- Remove the batteries when storing the instrument for a long period. Do not leave the exhausted batteries in the battery comparement and exchange the battereis on time.
- … Failure to do so may cause the batteries leakage and the instrument damage.



Using properly

- Matching the correct AC adapter outward as requested.
- … or may cause the instrument damage.



Forbidden

- Do not wipe the instrument with a volatile solvent.
- … the body may deform or deteriorate. Use a soft dry cloth to remove stains. If stains persist, soak the cloth in a neutral detergent and wipe the instrument with the soft cloth. Never use volatile solvents such as thinner or benzene.



Forbidden

- Do not use or leave the instrument in a high temperature, high humidity or dusty environment. Do not leave the instrument under direct sunlight.
- … otherwise, the instrument may not function properly out of the specified operating conditions or the inside components damaged.

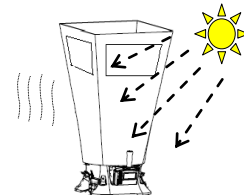

Forbidden

- Never dropping the unit or placing heavy objects on it
- … It may cause damage or malfunction to the instrument

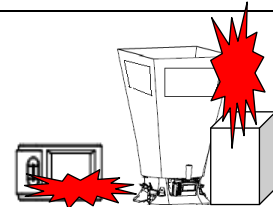

1. Introduction

Capture Hood Model 6715 is a kind of intelligent test instrument with multi functional of airflow test, velocity test and micro- Differential pressure test. It's widely used in air flow and velocity testing of air - conditioning, HAVC system and other places, especially for the high precision micro differential pressure test.

1.1. Features

- ◆ 3.5 inch true color LCD.
- ◆ Available measuring the air flow, velocity, temperature and humidity at the same time.
- ◆ Two kinds of tests are available of in flowing and exhaust flowing.
- ◆ Back pressure compensation.
- ◆ Ultra-large Storage capacity: 8000 records
- ◆ Blue tooth communication makes remote monitoring and data transferring available.
- ◆ Light weight, compact configuration for easy carrying.
- ◆ Data printing or transferring to the computer.

1.2. Specifications

Items		Specifications
Air flow	Test range	40~4300 m ³ /h
	Accuracy	±3% of readings ± 10m ³ /h (>85m ³ /h)
	Resolution	1 m ³ /h
Air velocity	Test range	0.15~40 m/s (Pitot Tube)、0.15~15 m/s (Velocity Matrix)
	Accuracy	±3% of readings ±0.05m/s (>0.25m/s)
	Resolution	0.01m/s
Differential pressure	Test range	-2500~2500 Pa
	Accuracy	±0.25% of readings ±1Pa
	Resolution	0.001 Pa
Temperature	Test range	0~60°C
	Accuracy	±0.5°C
	Resolution	0.1°C
Humidity	Test range	0~100%RH
	Accuracy	±3%RH (10~90%RH)
	Resolution	0.1%RH
Absolute pressure	Test range	70~130 kPa
	Accuracy	±2% of readings
	Resolution	0.1 kPa
Operation Temp.		0~60°C (non condensing)
Storage Temp.		-20~70°C (non condensing)
Power Source		4 pcs of AA-size battery (approx. 9hrs available) or DC5V Adapter
Weight		3.6kg approx.

2. Outlook & Structure



2.1. Base structure

1. Outlook

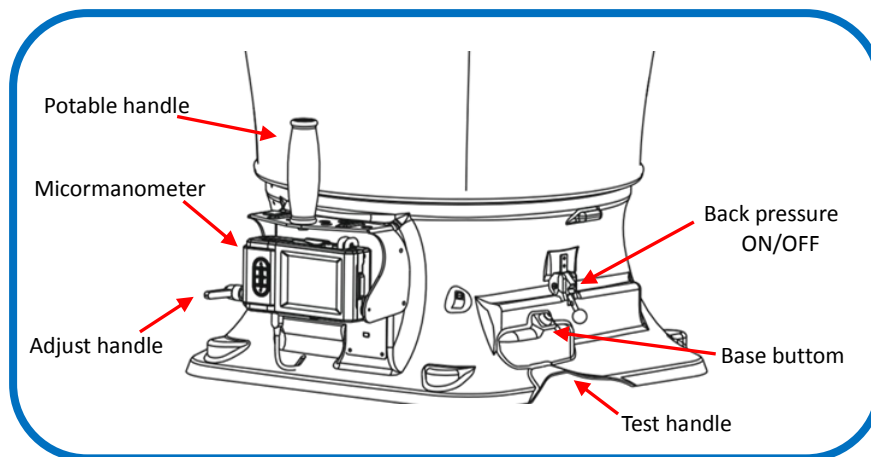

2. Internal view

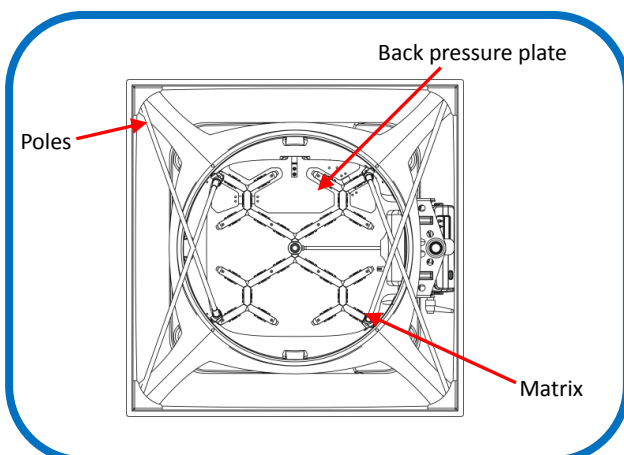

3. Matrix

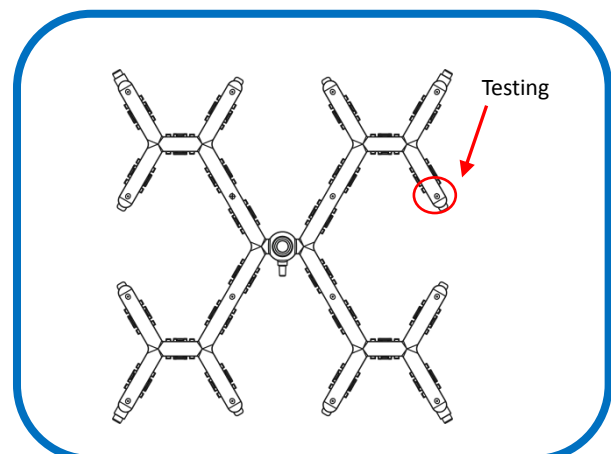

2.2. Micromanometer

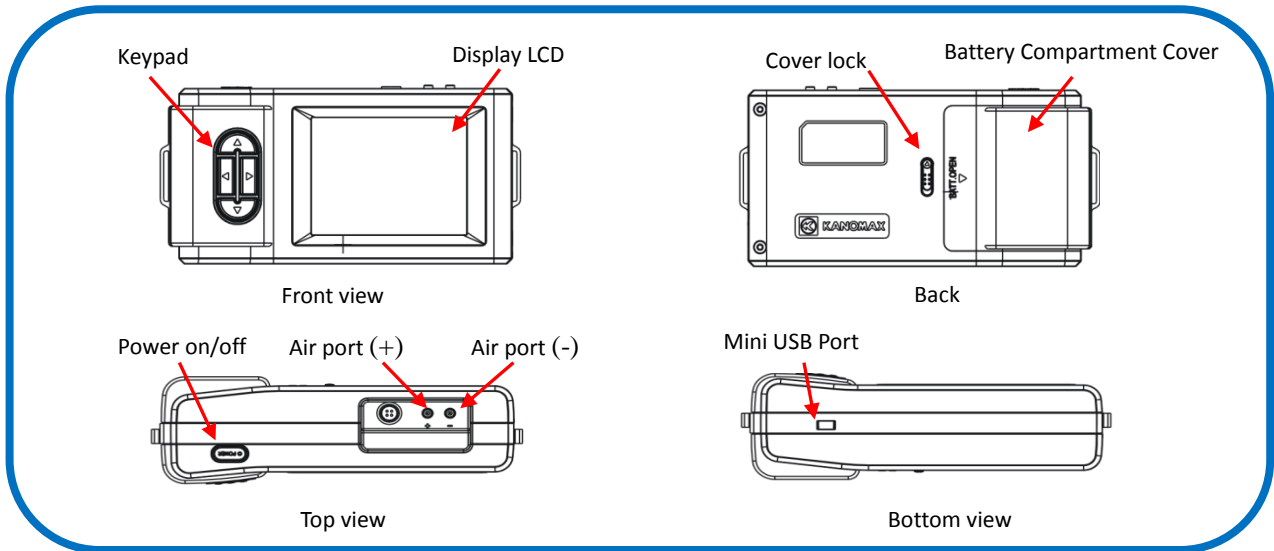

3. Setup up

3.1. Capture Hood

1. Fabric Hood & basement

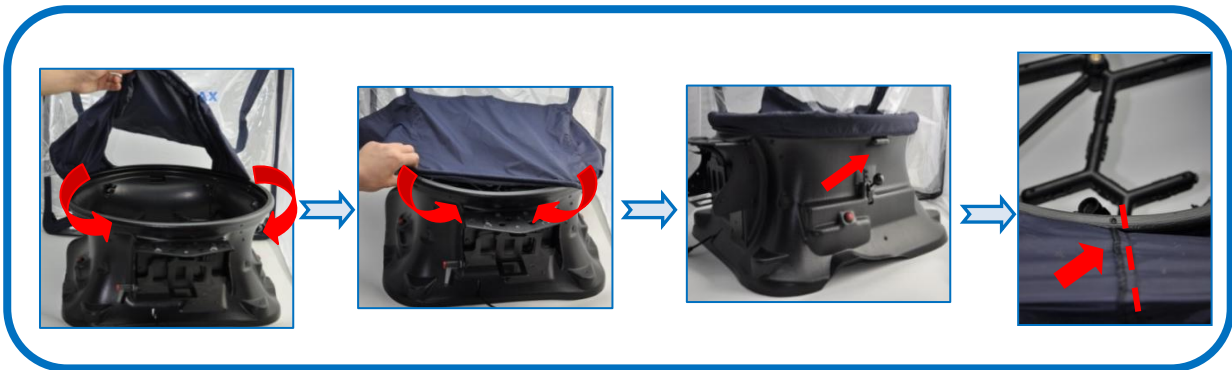

Note: Make 4 position holes on base stitching as a guide to ensure the hood fully wraps around the base.

2. Frame Poles



Note: The poles always cross in an "X" shape when assembling. To remove the poles, simply reverse the steps.

3. Potable handle

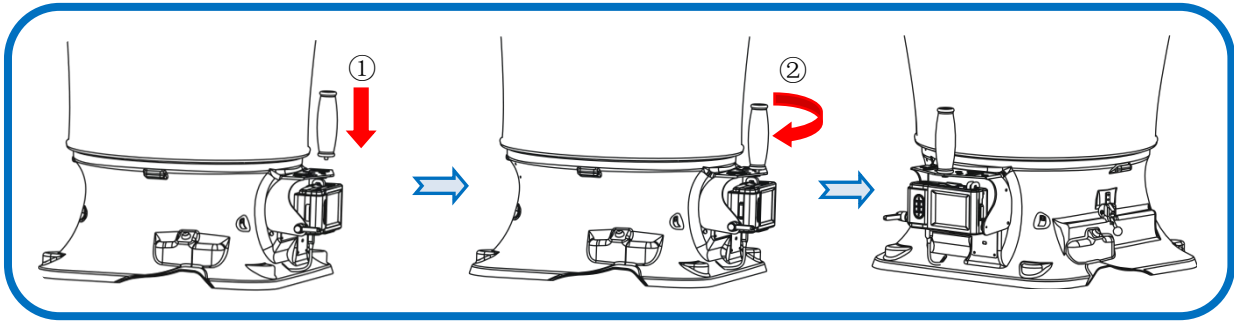

Note: Release the poles and portable handle when packing in the carrying case to avoid case damaged.

4. Micromanometer & basment

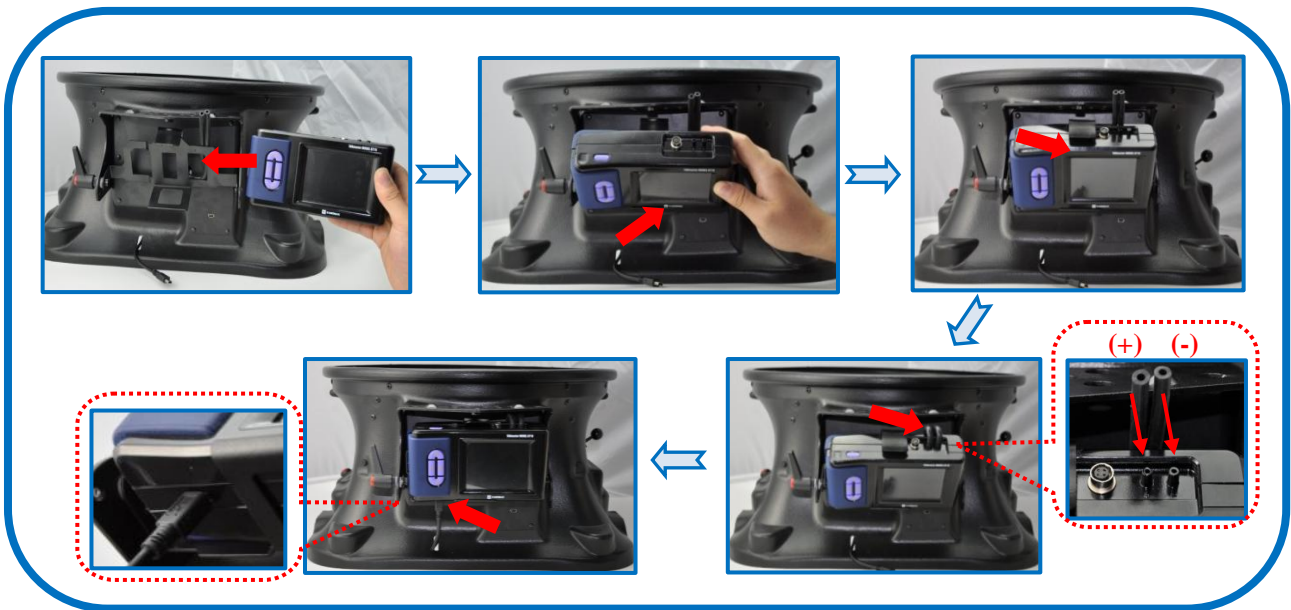

Note: 1) Correct install the micromanometer to the base with the same S/N No.

2) Do not cross- insert the Air pines just refer to the figure as above.

3.2. Velocity Matrix

Air velocity testing can be achieved when micromanometer work together with the velocity matrix.

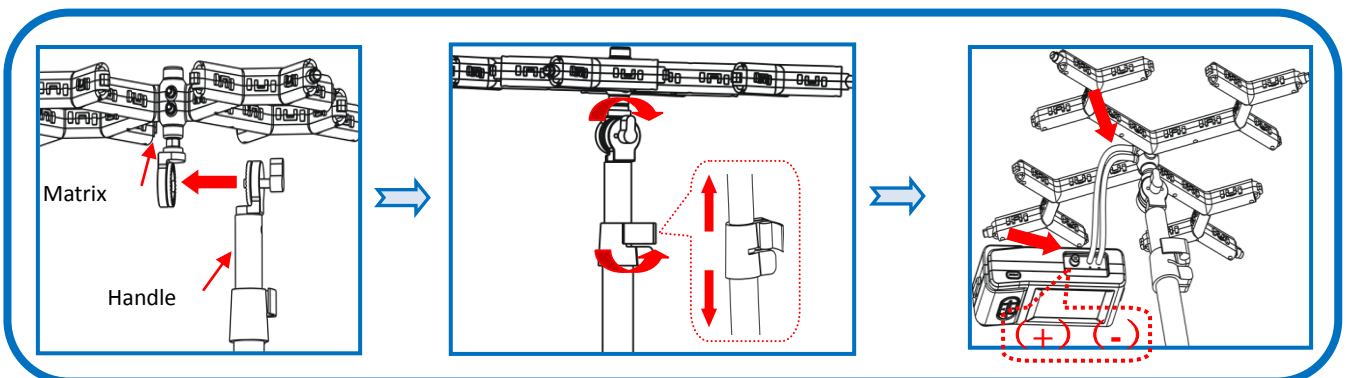

Note: Mounting angle between the matrix and handle can be adjusted as request.

3.3. Pitot tube

Air flow and velocity testing can be achieved when micromanometer work together with Pitot tube.

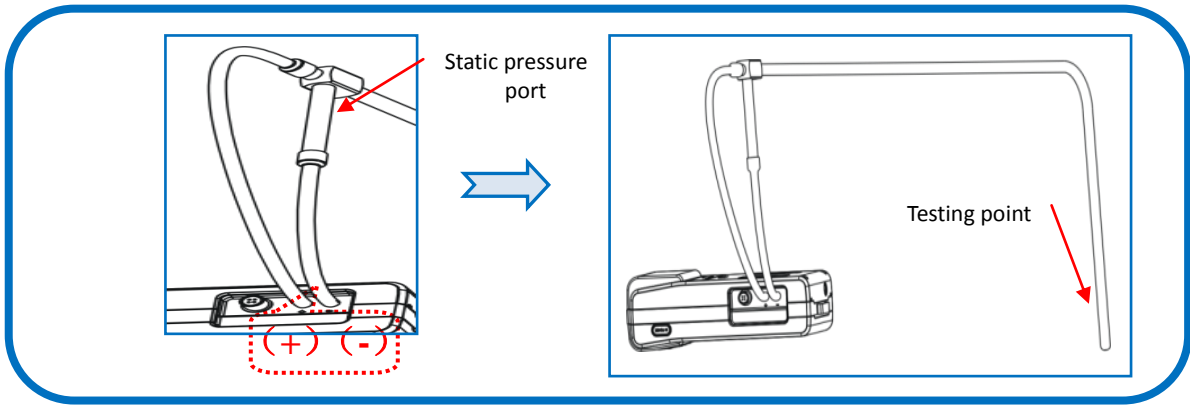

3.4. Micromanometer testing

Differential pressure testing can be achieved by using the micromanometer.

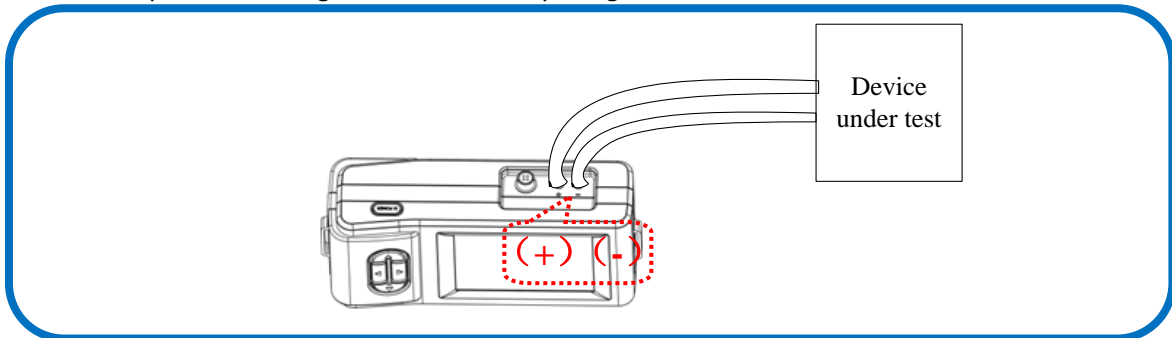

3.5. Shoulder Strap

When testing by Velocity Matrix, Pitot tube, Micromanometer as the tool, for convenient view and easy operation, the shoulder strap can be fit for using.



4. Operating Instruction

4.1. Power supply

1. Power by AC adapter. AC adapter will be as the priority power supply when the AC adapter and batteries are all available using. The specification of the AC adapter is: I/P:AC 110-240V 50/60HZ O/P:DC 5V/2A.

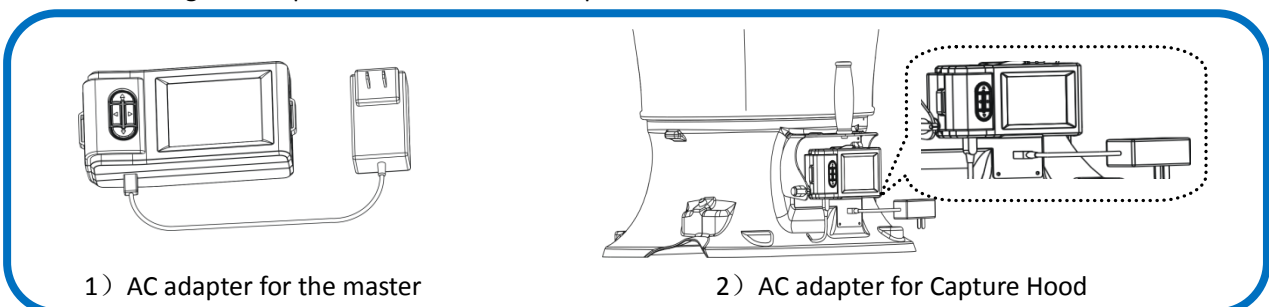

2. Power by battery

- ◆ 4 AA-size batteries can be used for a power supply.
- ◆ Press the compartment cover lock (refer to figure indicating ①/②), and then slide the cover off to open the battery compartment.
- ◆ Put 4 AA-size batteries in and make certain the batteries are correctly oriented.
- ◆ New alkaline battery or rechargeable Ni-MH battery can be used. Never mix battery types, or battery leakage or damage to the instrument may occur.
- ◆ Replace the compartment cover (refer to figure ③). The compartment cover will be automatically locked.

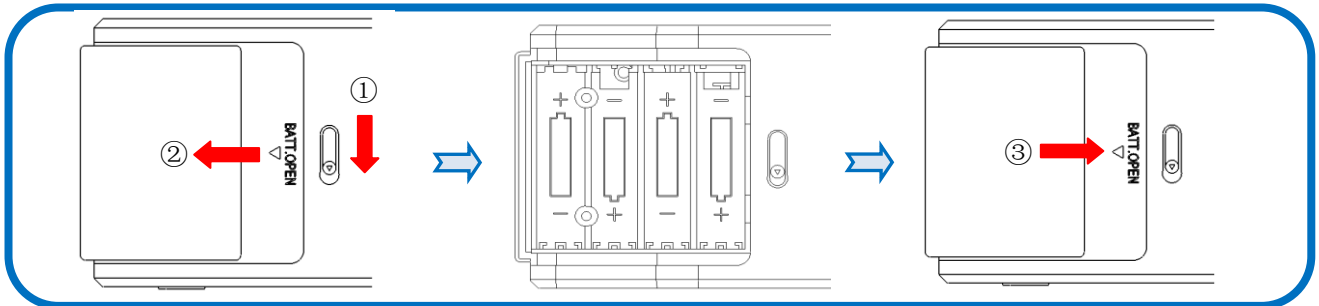

- ◆ When power is supplied with batteries, the current charge value will be displayed on the upper of the LCD. When the batteries run out of power, the instrument will turn off.

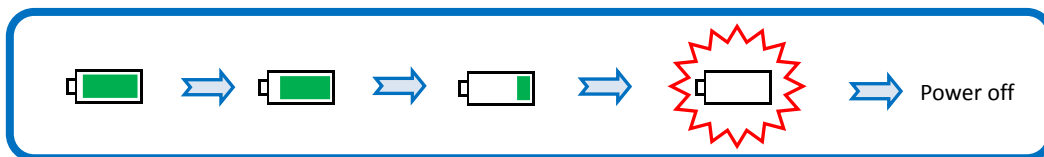

Note:

- 1) Do not test with low battery power.
- 2) Do not mixing use full power battery with low power ones for ensure testing well.
- 3) Change the batteries in time when power shows low for ensure testing well.

4.2. Start On / Power Off



1. Start On

Press button **【POWER】** for 2 seconds for start On, displaying “KANOMAX” then enter into the testing interface.

2. Power Off

Press **【POWER】** for 2 seconds, shut down and power off.

4.3. Keypad operation

Keypad panel includes control buttons, back-pressure switch and LCD adjusting keys.

1. Control buttons:

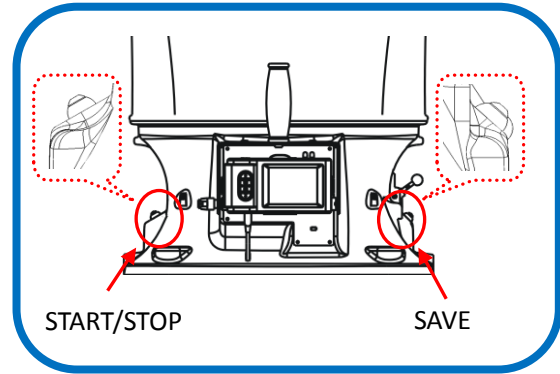
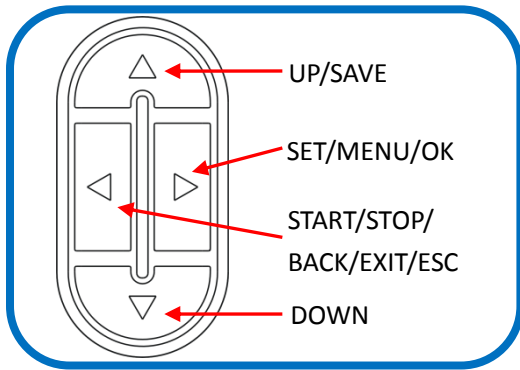

UP: Value increasing or Cursors upward moving.

SAVE: Save the current test results

SET: Store changes or enter into the selected option's next level interface

MENU: On the main screen holding this down for 2 seconds will enter into the main "MENU"

OK: In the "General Setting", pressing for 2 seconds will save the date or time ;

While in the "Record Processing", pressing for 2 seconds will delete saved data.

START: Begin a measurement in main menu

STOP: Stop a measurement in main menu

BACK: Cancel or end an operation or return to the previous screen

EXIT: Return to the main menu

ESC: Stop printing when printing

DOWN:: Value decreasing or Cursors downward moving

2. Back pressure switch for on/off

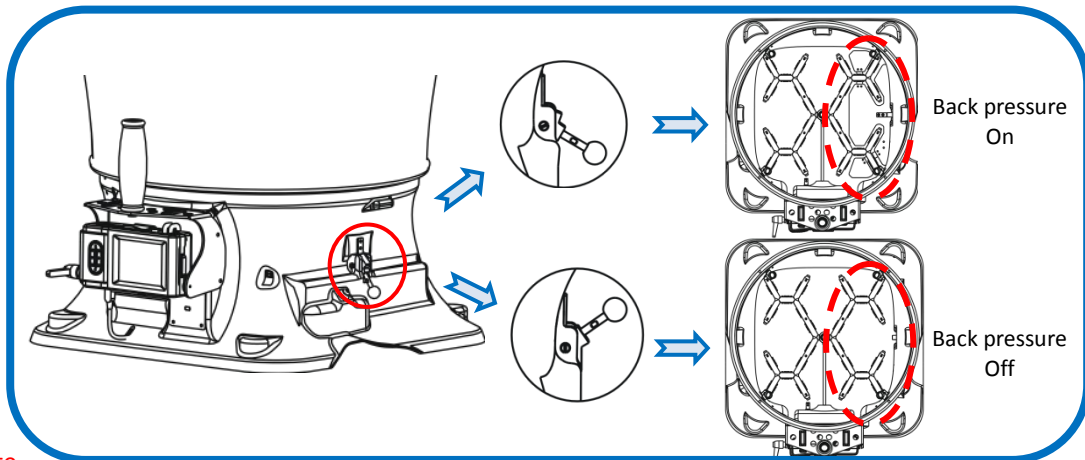

Note :

- 1) in Non-back pressure Mode, shut down the back pressure plate and lock the switch for avoiding testing error.
- 2) when airflow larger than 1500m³/h , testing in back-pressure Mode is recommended and step by step according to testing procedures.

3. LCD adjusting

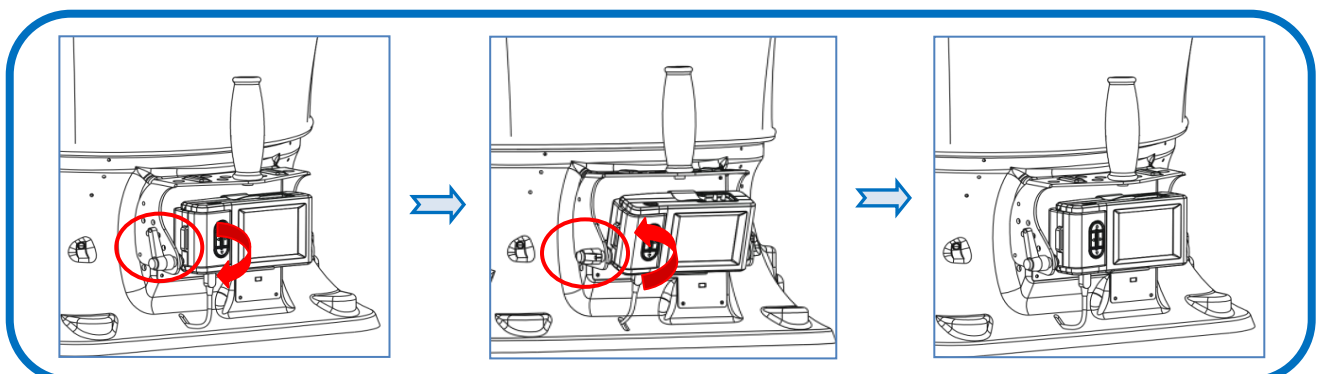

Note :

- 1) Please switching the handle slow gently during LCD adjusting.
- 2) Stop turning when reach to the bound, for avoiding over turning and handle falling down.

5. Function test

Besides the airflow test, if along with other optional products, test air velocity and micro-differential pressure is available.

5.1. User Interface

Testing information, parameter settings and the testing conditions will be displayed on the main interface.

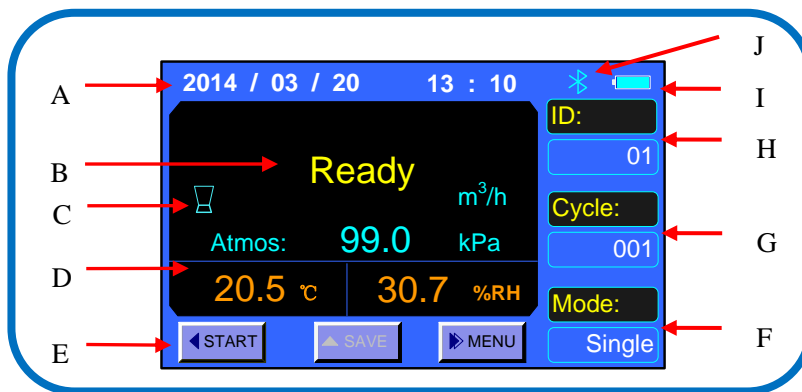

- A. Date and time —— real-time display the current date and time
- B. Testing data display —— airflow 、 air velocity 、 differential pressure and etc.
- C. Tools icon —— working tools display
- D. Testing condition —— temperature 、 humidity or absolute pressure displaying according to the working tools.
- E. Keypad —— current status indicating and the grey state is not available.
- F. Testing mode —— display the current testing mode
- G. Cycle—— recorded Cycle quantity
- H. ID—— current ID quantity
- I. Power supply —— AC adapter or batteries
- J. Blue tooth status —— when blue tooth working, the icon display or no icon display with closed.

5.2. Single Mode

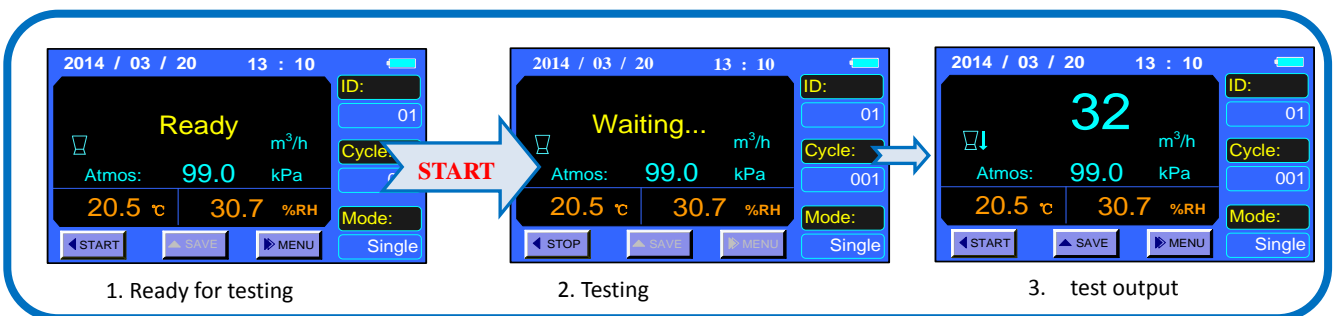

Note:

- 1) START: Left-button for the Micromanometer or instrument base
- 2) After testing start for about 8s with stably measuring,output displaying the test data and testing wind direction.
- 3) Testing stop when finish outputting.

- 4) Press SAVE for data record with adding 1 to the Cycle value.
- 5) Same testing method with the capture hood when using the Velocity Matrix, Pitot tube, Micromanometer.

5.3. Average Mode

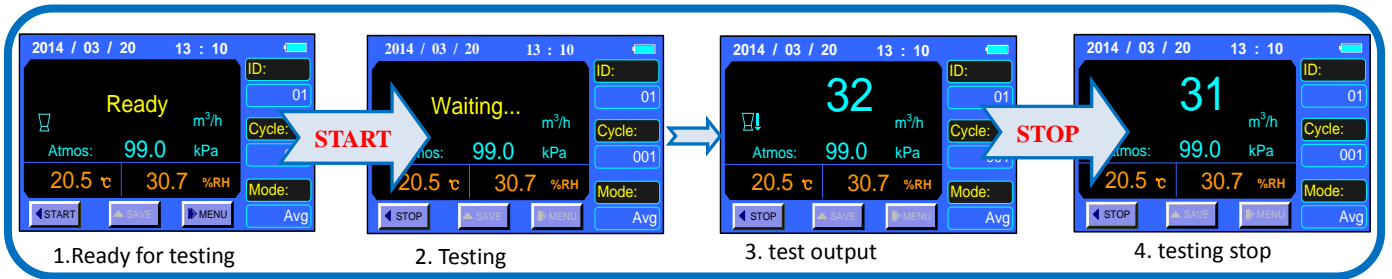

Note:

- 1) START: Left-button for the Micromanometer or instrument base.
- 2) After testing start for about 8s with stably measuring, output displaying the test data for the first time.
- 3) Go on the testing with frequency of 1s for data updating.
- 4) The continuously outputting is as the average data and be related with the “AvgTime” set by user. More larger of the value of “AvgTime” will get more stable of the testing data.
- 5) If auto-save function On, testing data will be recorded automatically according to the setting “AutoSave” and value of “Cycle” will be added automatically.
- 6) Press “STOP”, testing stop. And “STOP” will be as the Left-button for the Micromanometer or instrument base.
- 7) Same testing method with the capture hood when using the Velocity Matrix, Pitot tube, Micromanometer.

5.4. Back Pressure Mode

In order to reduce the measure error of the pressure loss, which causing from the hood to the system and get the more real air flow, we suggest testing under the Back Pressure Mode when air flow more than 1500 m³/h.

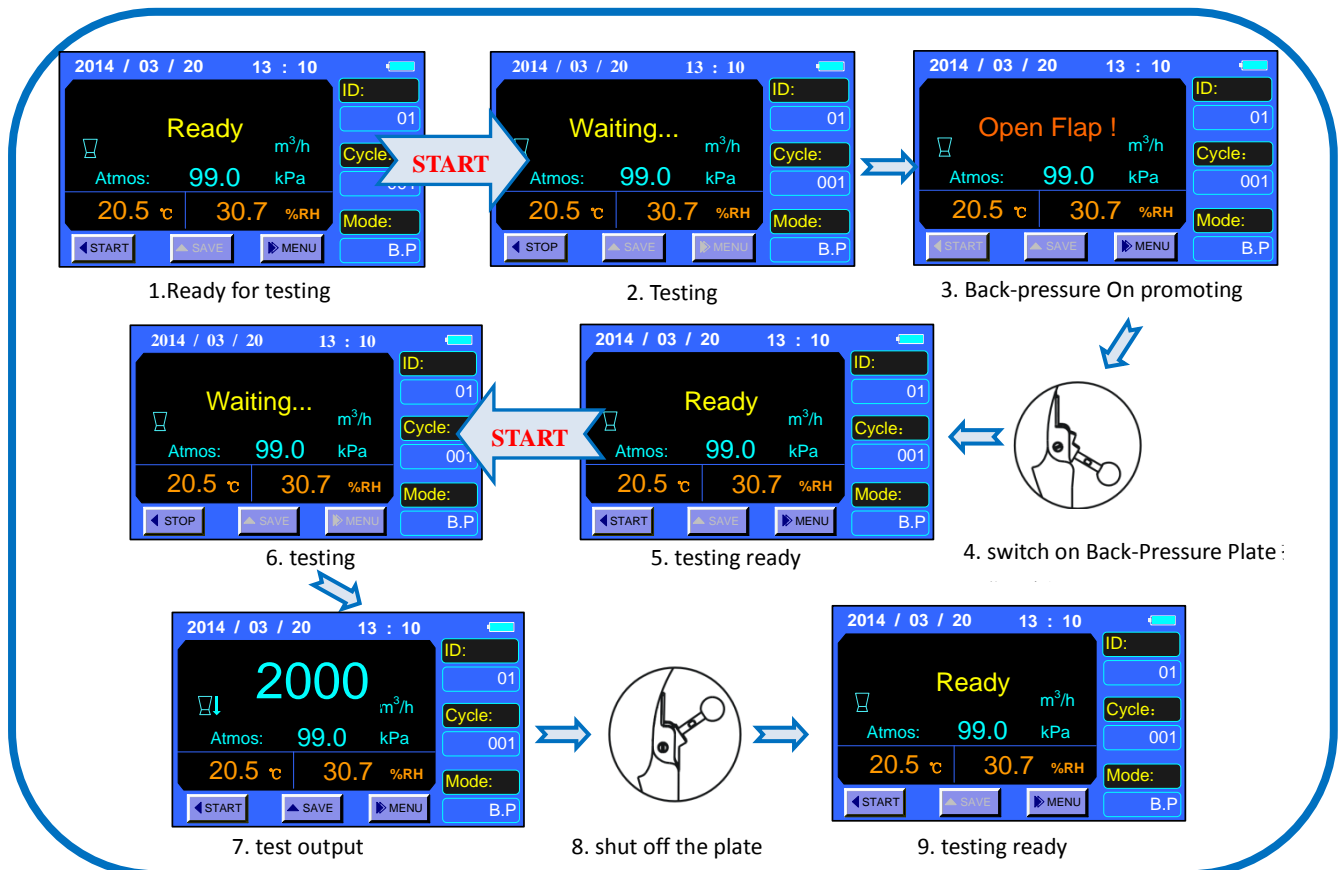

Note:

- 1) START: Left-button for the Micromanometer or instrument base.
- 2) After testing start for about 8s , indicating "Open Flap". It's time for switching on the Back-Pressure Plate as needed.
- 3) When Back-Pressure Plate opened On, tip of "Open Flap" disappear.
- 4) Press START for about 8s, testing stop, real airflow outputting with back pressure compensation.
- 5) Press SAVE for testing data record and the meanwhile, value Cycle added 1.
- 6) When select Velocity Matrix 、Pitot tube 、Micromanometer for testing, Back-Pressure compensation will be not available.

6. Menu setting

when stop for ready, press  for 2s for enter into the menu.

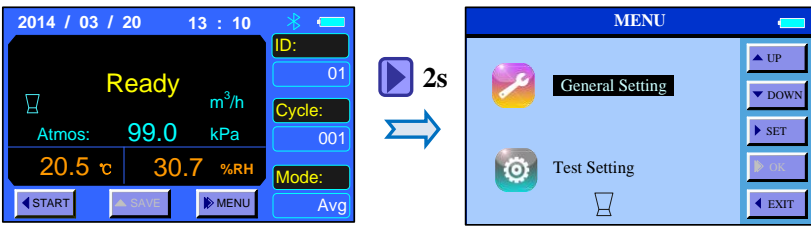

(1) 2 optional settings:

- 1) Basic setting
- 2) Test setting
- 3) Working tool displaying below

6.1. Basic setting

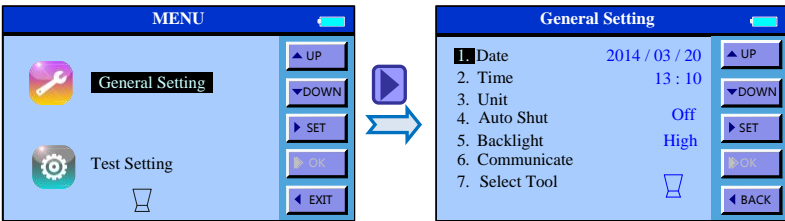



(1) Basic setting:

- 1) Date
- 2) Time
- 3) Unit
- 4) Auto Shut
- 5) Backlight
- 6) Communicate
- 7) Select Tool
- 5) Backlight
- 6) Communicate
- 7) Select Tool

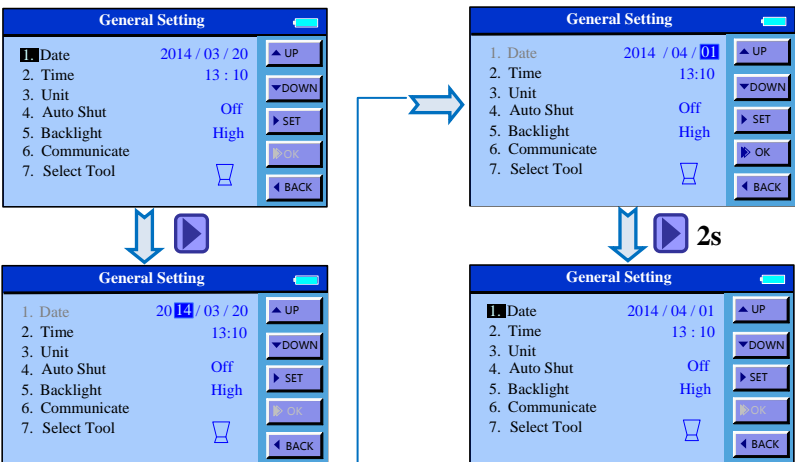
6.1.1. Date



(1) press  or  for data modify.

(2) press , for selecting Year/Month/day.

(3) Press  for 2s for save settings.

(4) Press  for quit.

6.1.2. Time

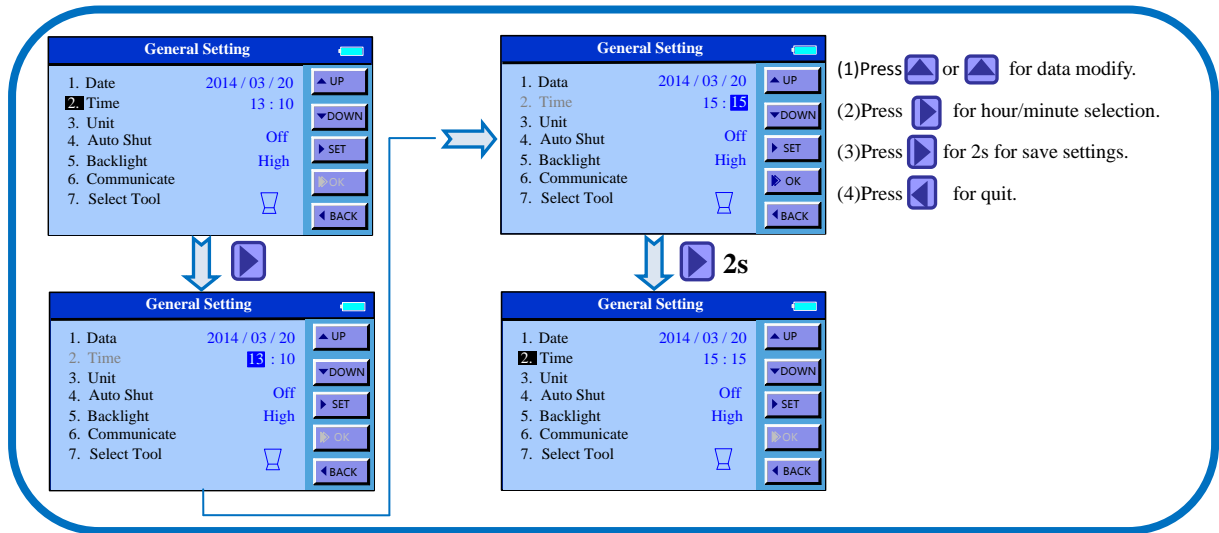

6.1.3. Units

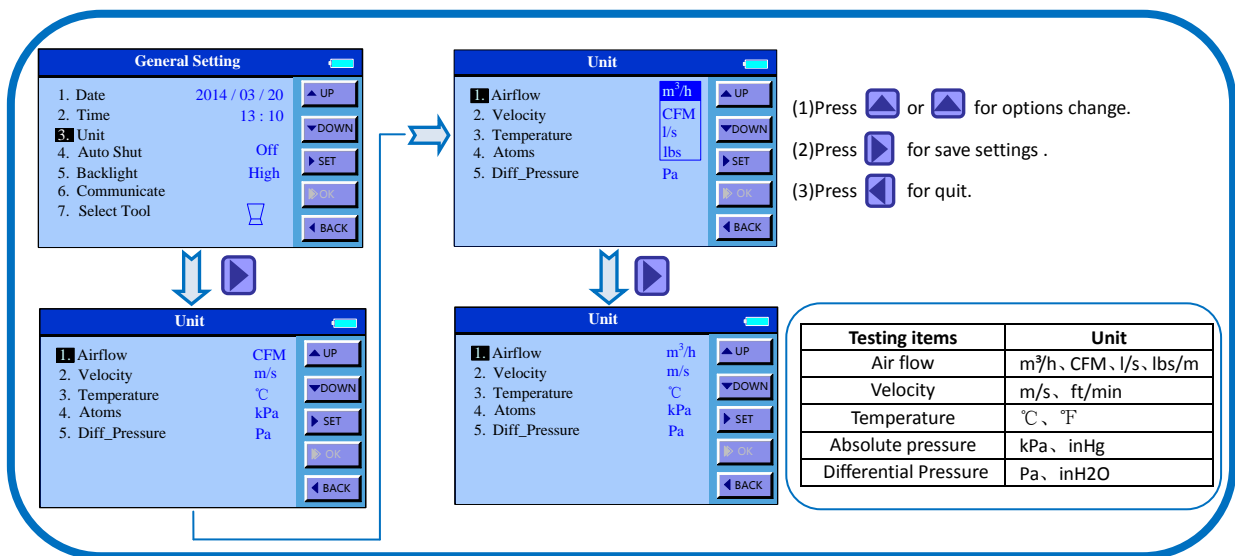

6.1.4. Auto Off

When instrument not in use, it will be turn off automatically according to Auto-Off time setting to avoid power waste.

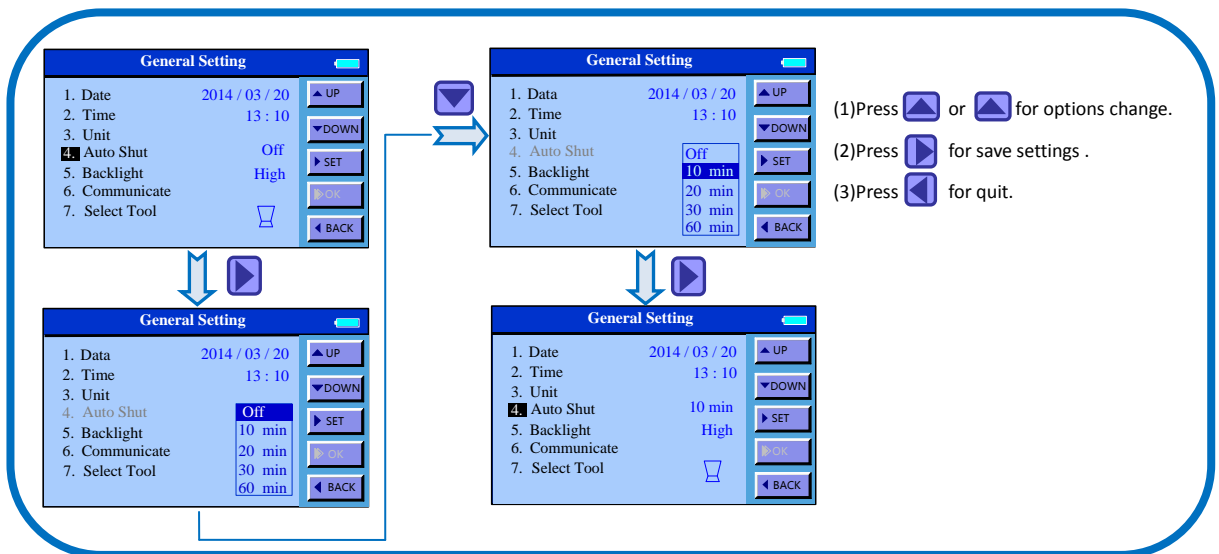

6.1.5. Backlighting

Adjust the LCD lighting according to the environmental brightness for the best viewing. And meanwhile, the lower the brightness, the less battery power will be needed.

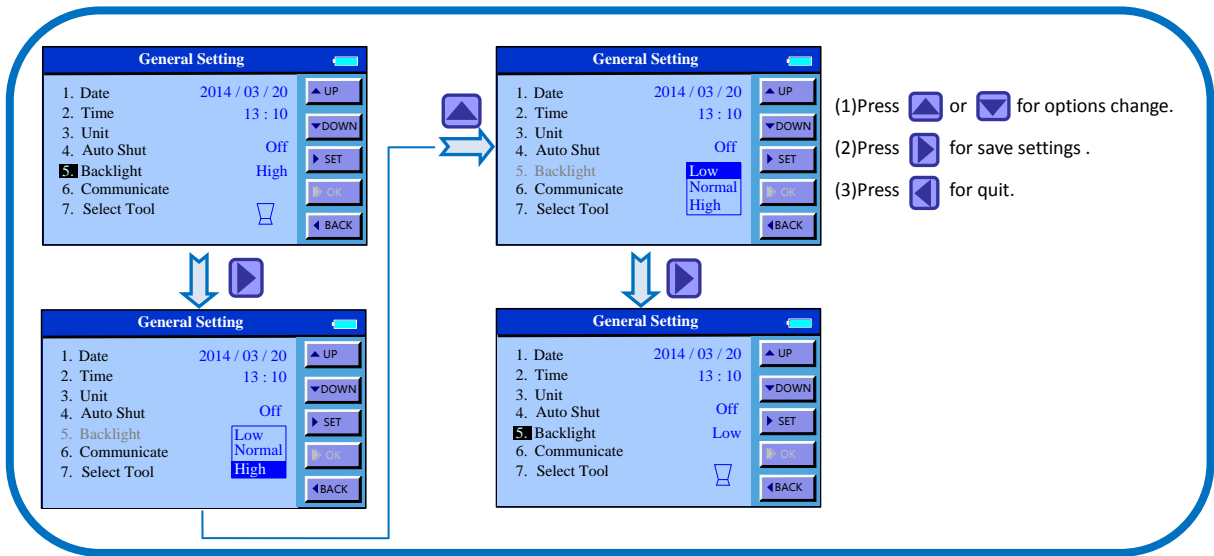

6.1.6. Communication

Communicate with PC, printer and Bluetooth are available. Data transfer or remote monitoring is available by selecting communicating way.

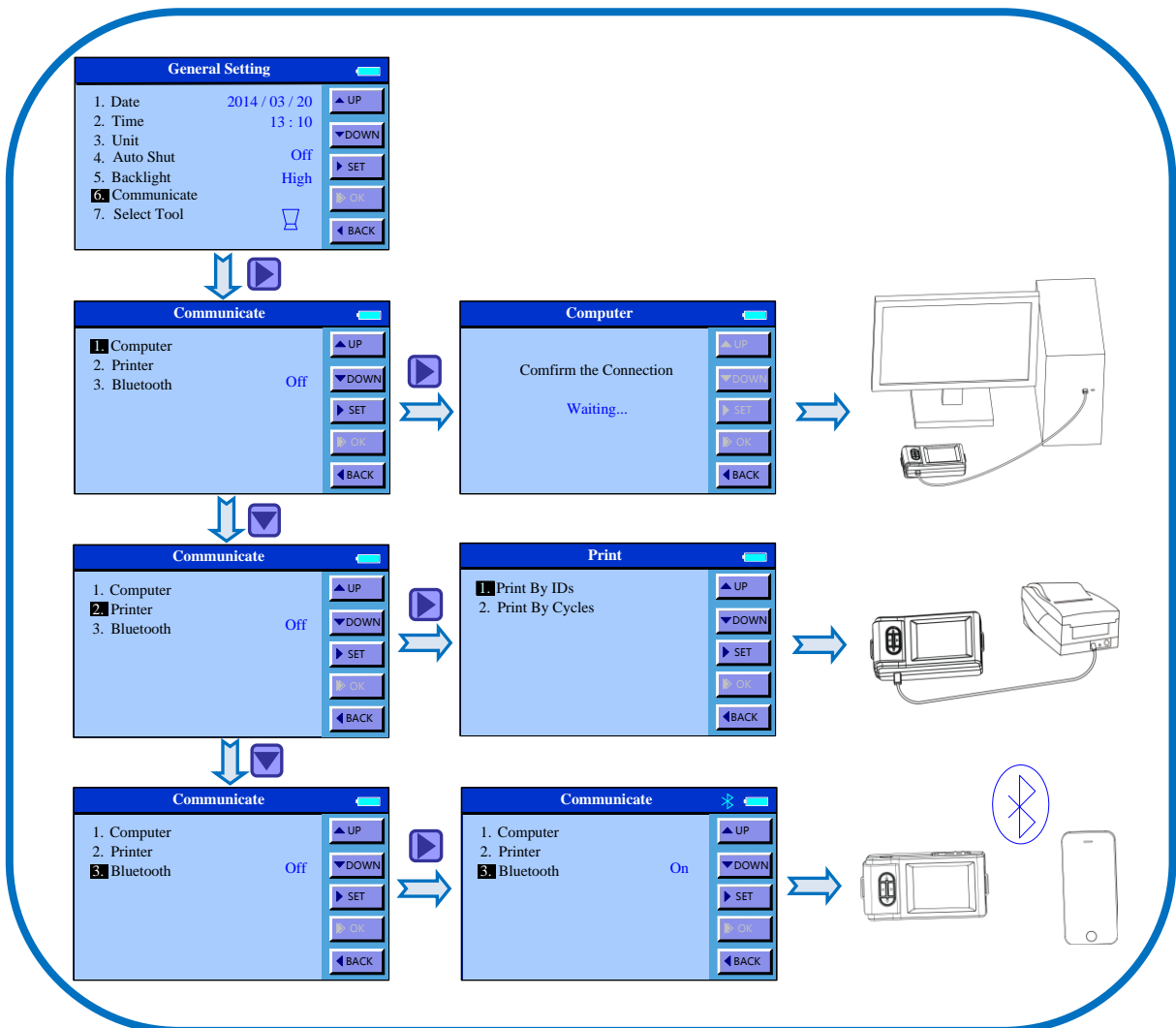

Note:

- 1) PC communication means to save the testing record to the computer. And the communication cable and software reserved for data-fetching are necessary for using together. Refer to the << Manuel for Data fetching Software>> .

- 2) For printing out the testing record, the optional printer and cables for special are necessary. Printer baud rate is set to 19200 bps and Do not change it. Refer to the << Manuel for RD series Mini printer >> .
- 3) Bluetooth make the remote control and data monitoring available by Hand phone or tablet PC. And our APP software is necessary for using together. Refer to the << Manuel for Bluetooth software>>.
- 4) Shut off the switch when not use the Bluetooth communication for improving battery life.

6.1.7. Tools

Capture Hood model 6715 is a intelligent instrument with airflow testing , air velocity testing and differential pressure testing. Different testing tools with different testing items will be achieved. Refer to the Chapter 3 and Chapter 5 in the Manuel for details.

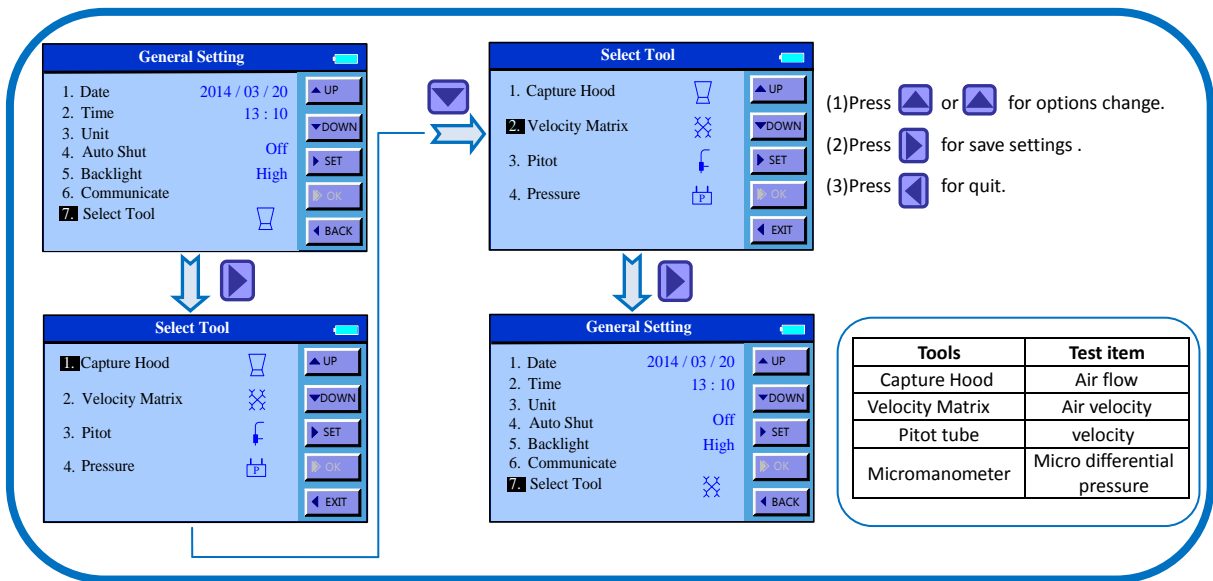

6.2. Test setting

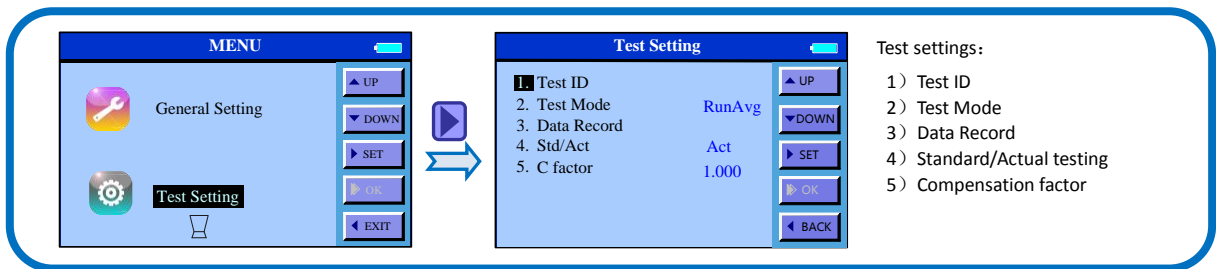

6.2.1. ID application

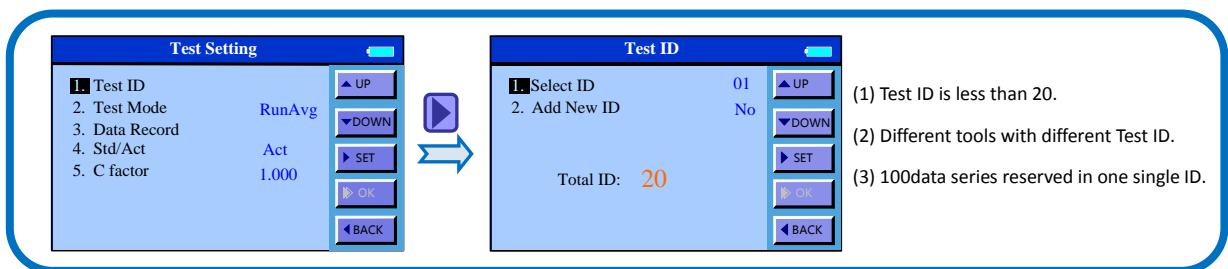

6.2.2. Test Mode



6.2.3. Data record

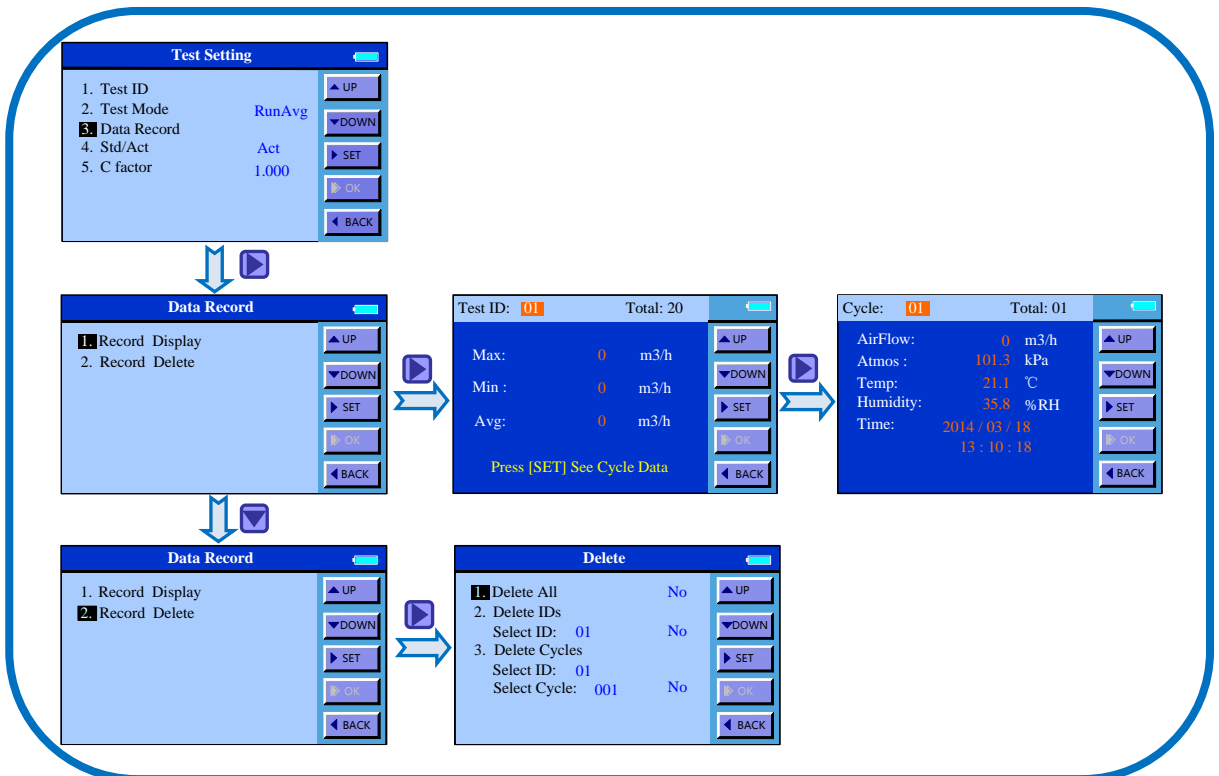

Note:

- 1) Browsing or deleting test data in current testing tools is available for allowed.

- 2) Data exporting by communication function and deleting the non-valid data in time for the effective storage space.

6.2.4. Standard/Actual test

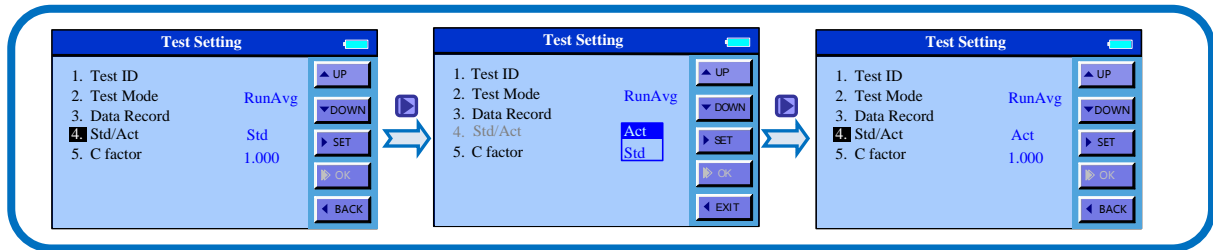

Note:

- 1) Standard Test (Std): in the condition of atmosphere 101.3kPa and temperature 21.1°C.
- 2) Actual Test(Act): in actual condition with the compensation for the atmosphere and temperature.
- 3) No Std/Act selection when in Micromanometer testing.
- 4) When doing actual testing under Velocity Matrix and pitot tube, manually input the current temperature is needed for the compensation. Refer to the figures as below:

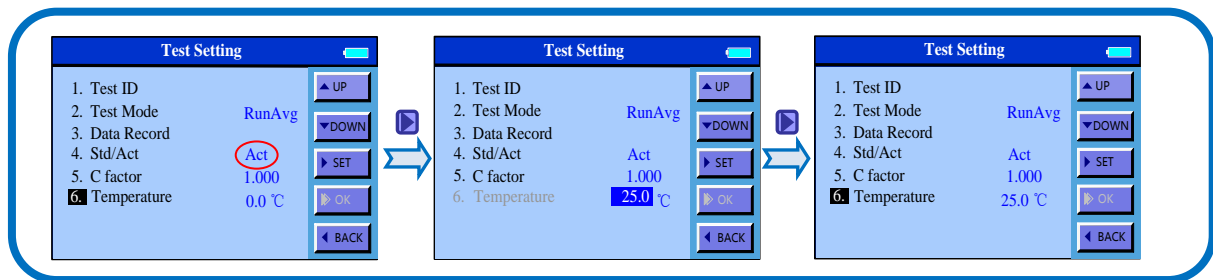

6.2.5. Compensation factor

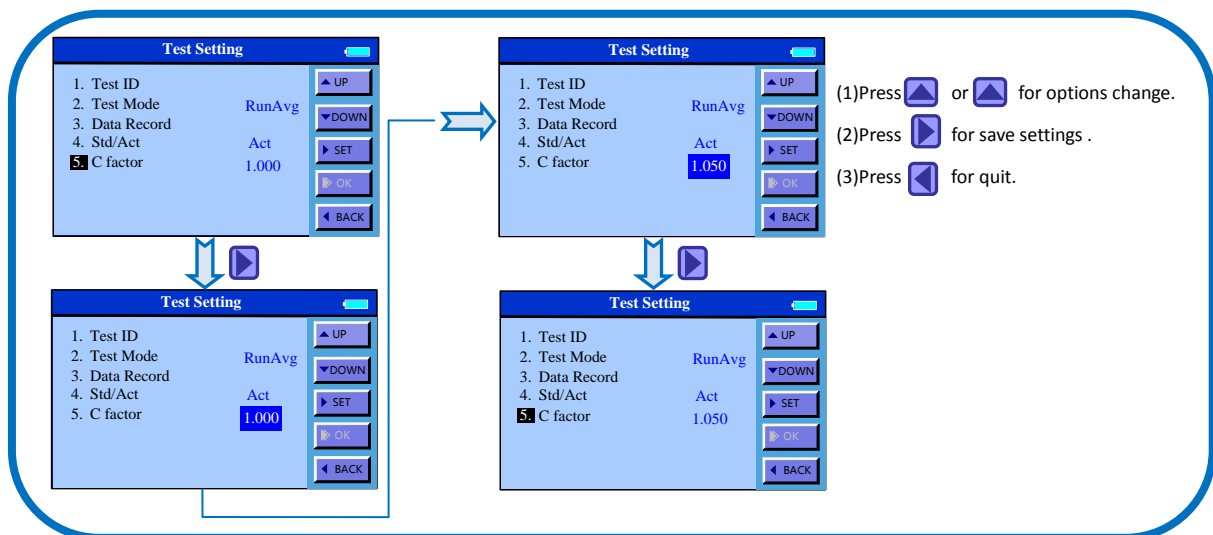

Note:

- 1) Under Capture Hood and Velocity Matrix testing, C- factor is used for testing data compensation in order to get more accuracy result.
- 2) Under Pitot tube testing, C- factor is the factory standard coefficient and each pitot with its own independent factor.
- 3) No C- factor setting under the micromanometer testing.

7 Error and Troubleshooting

Symptom	Possible causes	Corrective action
No display when power On	incorrect specification of the AC Adapter	Check and refer to Chapter4.1 in Manuel
	Battery installation error	Check and refer to Chapter4.1 in Manuel
	Low or dead battery power	Replace the batteries
Display "Connect Error"	Connection cable loss with the base	Reseat the connect cable
Display "DATA Error"	Back-Pressure mode using incorrect	Refer to Chapter 5.4 in Manuel
Press "START" but no response	Low battery charge	Replace new batteries
	Back Pressure Plate opened On	Shut off the plate
Testing record can not be saved	Over-limit Cycle quantity in current ID	Add new ID or delete some data
New ID can not be added	ID over-limit	Delete some ID
	Current ID is without "Cycle"	Using the current ID
Printing unreadable code	Unmatched printer	Using our special optional printer supplied by us.
	Wrong baud rate setting	Reset referring to the Printer Manuel

8 Warranty and Service

8.1. Product Warranty

The limited warranty set forth below is given by KANOMAX GROUP COMPANIES with respect to the KANOMAX brand capture hood and other accessories (hereafter referred to as “PRODUCT”) purchased directly from KANOMAX GROUP COMPANIES or from an authorized distributor.

Your PRODUCT, when delivered to you in new condition in its original container, is warranted against defects in materials or workmanship as follows: for a period of one (1) year from the date of original purchase, defective parts or a defective PRODUCT returned to KANOMAX GROUP COMPANIES, as applicable, and proven to be defective upon inspection, will be exchanged for a new or comparable rebuilt parts, or a refurbished PRODUCT as determined by KANOMAX GROUP COMPANIES. Warranty for such replacements shall not extend the original warranty period of the defective PRODUCT.

This limited warranty covers all defects encountered in normal use of the PRODUCT, and does not apply in the following cases:

- (1) Use of parts or supplies other than the PRODUCT sold by KANOMAX GROUP COMPANIES, which cause damage to the PRODUCT or cause abnormally frequent service calls or service problems.
- (2) If any PRODUCT has its serial number or date altered or removed.
- (3) Loss of damage to the PRODUCT due to abuse, mishandling, alternation, improper packaging by the owner, accident, natural disaster, electrical current fluctuations, failure to follow operation, maintenance or environmental instructions prescribed in the PRODUCT's operation manual provided by KANOMAX GROUP COMPANIES, or service performed by other than KANOMAX GROUP COMPANIES.

NO IMPLIED WARRANTY, INCLUDING ANY IMPLIED WARRANTY OF MERCHANTABILITY OR FITNESS FOR A PARTICULAR PURPOSE, APPLIES TO THE PRODUCT AFTER THE APPLICABLE PERIOD OF THE EXPRESS LIMITED WARRANTY STATED ABOVE, AND NO OTHER EXPRESS WARRANTY OR GUARANTY, EXCEPT AS MENTIONED ABOVE, GIVEN BY ANY PERSON OR ENTITY WITH RESPECT TO THE PRODUCT SHALL BIND KANOMAX GROUP COMPANIES. KANOMAX GROUP COMPANIES SHALL NOT BE LIABLE FOR LOSS OF STORAGE CHARGES, LOSS OR CORRUPTION OF DATA, OR ANY OTHER SPECIAL, INCIDENTAL OR CONSEQUENTIAL DAMAGES CAUSED BY THE USE OR MISUSE OF, OR INABILITY TO USE, THE PRODUCT, REGARDLESS OF THE LEGAL THEORY ON WHICH THE CLAIM IS BASED, AND EVEN IF KANOMAX GROUP COMPANIES HAS BEEN ADVISED OF THE POSSIBILITY OF SUCH DAMAGES. IN NO EVENT SHALL RECOVERY OF ANY KIND AGAINST KANOMAX GROUP COMPANIES BE GREATER IN AMOUNT THAN THE PURCHASE PRICE OF THE PRODUCT SOLD BY KANOMAX GROUP COMPANIES AND CAUSING THE ALLEGED DAMAGE. WITHOUT LIMITING THE FOREGOING, THE OWNER ASSUMES ALL RISK AND LIABILITY FOR LOSS, DAMAGE OF, OR INJURY TO THE OWNER AND THE OWNER'S PROPERTY AND TO OTHERS AND THEIR PROPERTY ARISING OUT OF USE OR MISUSE OF, OR INABILITY TO USE, THE PRODUCT NOT CAUSED DIRECTLY BY THE NEGLIGENCE OF KANOMAX GROUP COMPANIES. THIS LIMITED WARRANTY SHALL NOT EXTEND TO ANYONE OTHER THAN THE ORIGINAL PURCHASER OF THE PRODUCT, OR THE PERSON FOR WHOM IT WAS PURCHASED AS A GIFT, AND STATES THE PURCHASER'S EXCLUSIVE REMEDY.

8.2. After service

- ◆ When you have a problem with your instrument, please check out the “Common Trouble Shooting” section first.
- ◆ If that does not help, please contact your local distributor, or contacts on the last page.
- ◆ During the warranty period, we will repair at no charge a product that proves to be defective due to material or workmanship under normal use. (See Section 14.1 Warranty)
 - All return shipping charges are the responsibility of the customer.

- ◆ Repair after warranty expiration:
 - Upon request, we will repair the instrument at the customer's expense, if the instrument's performance is found to be recoverable by providing the repair.
- ◆ Replacement parts are available for a minimum period of five (5) years after termination of production. This storage period of replacement parts is considered as the period during which we can provide repair service. For further information, please contact your local distributor, or contacts on the last page.

When making an inquiry, please provide the following information:

- * PRODUCT NAME Capture Hood
- * Model No. 6715
- * Serial No. -----
- * Description of the problem in detail:
- * Data of Purchase: Day, Month and Year



KANOMAX
The Ultimate Measurements

Kanomax Group Companies

Americas, Europe, Mid-East, Africa, Oceania

KANOMAX USA, INC.

219 US Highway. 206, Andover, New Jersey 07821

Tel: 1-800-247-8887(USA) / 1-973-786-6386

FAX: 1-973-786-7586

URL : www.kanomax-usa.com

E-Mail: info@kanomax-usa.com

Se Habla
Espanol

Japan & Asia

KANOMAX JAPAN, INC.

2-1 Shimizu Suita City, Osaka Japan 565-0805

Tel: 81-6-6877-0183

FAX: 81-6-6879-2080

URL : www.kanomax.co.jp

E-Mail: sales@kanomax.co.jp

China

Shenyang Kano Scientific Instrument Co., Ltd

#2610, 51 Wulihe Street Heping District, Shenyang City, PRC

Tel: 86-24-23845309

FAX: 86-24-23898417

URL : <http://www.kanomax.com.cn/>

E-Mail: sales@kanomax.com.cn