

O₂ SENSOR CHECKER

Instruction Manual

SK-8402

KAISE CORPORATION



INTRODUCTION

Thank you for purchasing KAISE "SK-8402 O2 SENSOR CHECKER". To obtain the maximum performance of this instrument, read this Instruction Manual carefully, and take safe measurement.

CONTENTS

SAFETY PRECAUTIONS	1~5	BASIC CONNECTION DIAGRAM	23
OPERATING PRECAUTIONS	6~7	NORMAL TEST	
FEATURES	8	1. Measurement Flow Chart	24
UNPACKING AND INSPECTION	9	2. Measurement Procedure with Check Harness	25~31
NAME ILLUSTRATION	10	3. Measurement Procedure with Test Pin	32~33
SPECIFICATIONS		SIMULATION TEST	34~38
1. General Specifications	11~12	MAINTENANCE	
2. Measurement Specifications	13	1. Battery Replacement	39
3. LCD Specifications	13~14	2. Periodical Check and Calibration	39
4. Simulation Test	14	TROUBLE SHOOTING	40
BEFORE USE		WARRANTY	41
1. Types of O2 Sensors	15		
2. Battery Installation	16		
3. Confirmation of O2 Sensor Cables	17		
4. Colors of O2 Sensor Cables	17		
PREPARATION FOR USE			
1. Inspection of Check Harness and Test Lead	18~20		
2. Check Harness Connection	21~22		

SAFETY PRECAUTIONS (strict observance is required)

This instruction manual contains the important contents to prevent harm to user or others and damage of property, and to use the instrument safely and correctly.

Read this manual carefully and obey the contents after having understand the following terms and symbols.

■The points where the following symbols are attached in this manual describe the degree of harm and damage that would be caused by incorrect usage due to neglect of this description.

**WARNING**

This symbol in this manual advises the user of an electrical shock hazard that could result in serious injury or even death.

**CAUTION**

This symbol in this manual advises the user of an electrical shock hazard that could cause injury or material damages.

■The points where the following symbols are attached in this manual describe the matters which must obey in accordance with the each meanings. (following symbols are some examples.)



This symbol shows the warnings and cautions.



This symbol shows the prohibited matters.



This symbol shows the matters that is forced to do.

SAFETY PRECAUTIONS (strict observance is required)

⚠ WARNING

Be careful about your hands, gloves and clothes not to be caught in the engine belt or cooling fan.

Important to prevent injury.



Do not to touch the heated part of the engine such as exhausting parts.

Important to prevent burn injury.



Be careful not to catch your feet in the test leads.

Important to prevent injury.



Confirm that the shift lever is set to "Parking" position (set to "Neutral" for stick shift car).

The car runs accidentally and could cause unexpected accident, electric shock, or damage to the instrument or the car.



Confirm that the parking brake is applied.

The car runs accidentally and could cause unexpected accident, electric shock, or damage to the instrument or the car.



Take the measurement or its preparation under well-ventilated environment.

Carbon monoxide poisoning may occur due to the engine running during the measurement.



Use the supplied test leads and cables when taking the measurement.

Important to prevent any accident, electric shock, or damage to the instrument or the car.











Use the "car lift" when lifting the car for measurement preparation.

Important to prevent any accident.



SAFETY PRECAUTIONS (strict observance is required)

 **WARNING**

<p>Keep the instrument away from babies or children. Important to prevent any accident, injury, or electric shock hazard.</p>	
<p>Do not work under the car when it is jacked up. Unexpected accident may occur.</p>	
<p>Do not drive the car keeping the instrument connected. Unexpected accident, electric shock, fire, or damage to the instrument or the car may occur.</p>	
<p>Do not open the battery cover keeping the instrument connected to the car. Electric shock may occur.</p>	
<p>Do not replace the battery with the wet hands. Electric shock may occur.</p>	
<p>Do not point the tip of Test Pin or Check Harness at the person. Loss of eyesight or injury may occur.</p>	
<p>Do not work in the dark place. Unexpected accident, electric shock, fire, or damage to the instrument or the car may occur.</p>	
<p>Do not get the instrument wet. Fire or electric shock may occur.</p>	

SAFETY PRECAUTIONS (strict observance is required)

 **WARNING**

Do not use the faulty instrument that can recognize such as display trouble, switch failure.

Stop using the instrument immediately and consult with your local dealer.
Using the faulty instrument may cause the unexpected accident, fire, or electric shock.



Do not use the instrument if it is in the abnormal condition.

Stop using the instrument immediately and consult with your local dealer when recognizing smoke, strange smell, or abnormal noise.
Using the faulty instrument may cause the unexpected accident, fire, or electric shock.



Do not attempt to disassemble or modify the instrument.

Fire, electric shock, or damage to the instrument may occur.



Do not use the Test Lead or Check Harness with which coating were damaged by heat.

Fire or electric shock may occur.



SAFETY PRECAUTIONS (strict observance is required) **CAUTION****Be careful about the instrument or the cables not to be caught in the engine belt or cooling fan.**

Short circuit or wire breaking may occur that could cause unexpected accident, electric shock, or damage to the instrument or the car.

**Be careful about the instrument or the cables not to touch the heated part of the engine such as exhausting parts.**

Important to prevent any accident, electric shock, or damage to the instrument or the car.

**Do not use this instrument for a purpose other than O2 Sensor measurement.**

Unexpected accident or damage to the instrument may occur.

**Do not use any battery that have wrong rated specification.**

Fire, injury, or damage to the surroundings may occur due to battery explosion or leakage.

**Install the battery with the correct polarity as shown in the plus \oplus and minus \ominus indications.**

Installing with wrong polarity may cause fire, injury, or damage to the surroundings due to battery explosion or leakage.

**Dispose the exhausted battery in accordance with the local government rule after applying adhesive tape to both electrodes for insulation.**

Disposing the battery with other conductive materials such as metal pieces may cause the fire or battery explosion due to their short circuit.

**Do not heat or disassemble the battery. Do not put the battery into the fire or water.**

Fire or injury may occur due to battery explosion or leakage.



OPERATING PRECAUTIONS

- SK-8402 is the O2 Sensor Checker for the O2 sensor of Zirconia, Titania 1V and Titania 5V. SK-8402 can not check deterioration judgment of A/F (air-fuel ratio) Sensor or Rear O2 Sensor.
- Check object of this instrument is O2 sensor unit only. If the other parts are defective, engine trouble might not be solved even if the O2 sensor is replaced.
- To obtain the stable measurement, keeping the engine speed at approx. 2,500rpm for 3 to 4 minutes to warm up the O2 sensor is necessary. When measuring the car without tachometer, estimate the engine speed by its sound. Keeping the constant engine speed at approx. 2,500rpm is also necessary during the normal test mode.
- Scanning tool which can live monitor of ECU control is required to check ECU in simulation test.
- Error code is memorized in Engine Control Unit (ECU) when taking off the connector of O2 sensor with the ignition key switch is activated and the engine is running. Error code must be deleted by using the Code Reader or equivalent tool to prevent any engine troubles.
- Do not apply any oil to Input Terminal, Test Lead, Check Harness, Alligator Clip or metal part of Test Pin to prevent contact failure.
- Do not polish the case with the fluid that contains alcohol to prevent the cracking.
- Use this instrument under the environment of 0°C to 40°C, 80%RH or less to obtain the accurate measurement.
- Test Lead or Check Harness that coating are heat damaged might cause the short circuit. Do not use them and replace into the new ones.
- Measurement by using the Test Pin might weaken the waterproof property of the connectors of O2 sensor and ECU. Wrap heat-resistance/waterproof tape around them after taking the measurement.
- Remove the batteries when the instrument is out of use for a long time. The exhaust battery might leak electrolyte and corrode the inside.

OPERATING PRECAUTIONS

Cautions for Handling

- **Do not apply mechanical shock.**
The shock such as dropping or beating might damage the instrument and may cause the trouble.
- **Do not pull cables forcibly.**
Pulling the cables forcibly, such as when removing the plugs from terminal, may cause the cable disconnection.
- **It might cause the instrument trouble if taking the simulation test with mischoice the type of O₂ sensor (zirconia, titania 1V or titania 5V).**
- **Do not take the simulation test for heater cable or power supply cable during the electric car components are activated. It may damage to the instrument.**

Cautions for safekeeping

- **Do not keep the instrument in the following place.**
 - The place where has the water splash
 - The place where applies the hard shock
 - -20°C or less, 60°C or more, 70%RH or more
 - The place where has the condensation
 - The place where is exposed to direct sunlight

FEATURES

- Deterioration level of O2 sensor can be checked easily by bar-graph.

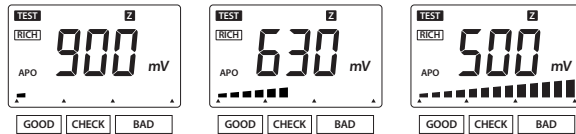

GOOD

(No problem)

CHECK

(replacement
recommended)

BAD

(replacement
required)

- Rich, Lean, Average voltages and Cycle are displayed respectively.

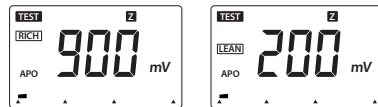

Rich voltage

Lean voltage

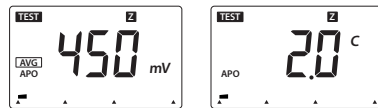

Average voltage

Cycle

- O2 sensor signal can be measured directly without changing the present exhaust system.

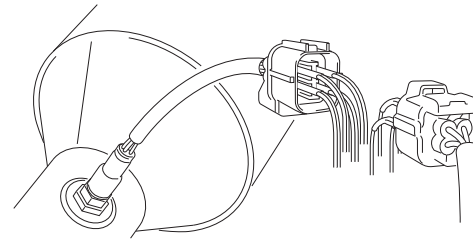

- Simulated sensor signal output is possible that is useful for checking wiring error or ECU control with a combination of scanning tool.

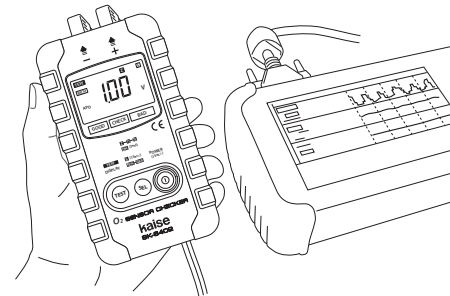

UNPACKING AND INSPECTION (Check before use)

Confirm if the following items are contained in the package in good condition.
If there are any damages or missing items, ask your local dealer for replacement.

① O2 Sensor Checker...1pce.



② Test Lead (100-65)...1pce.

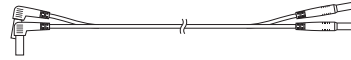

③ Check Harness (911)...1pce.

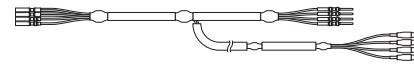

④ Alligator Clip (947)...1pce.

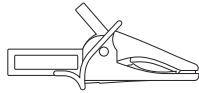

⑤ Test Pins: Red & Black (795)
...1pce. each

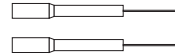

⑥ Carrying case (1030)...1pce.

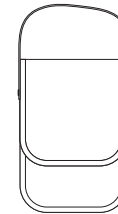

⑦ Batteries (manganese 1.5V R6P, AA)
...2pcs.

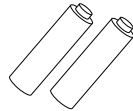

⑧ Instruction Manual...1pce.

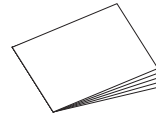

- Use parts numbers that are listed along with the parts names when ordering them for replacement.
- Use commercially available batteries for replacement.

NAME ILLUSTRATION

● O2 Sensor Checker

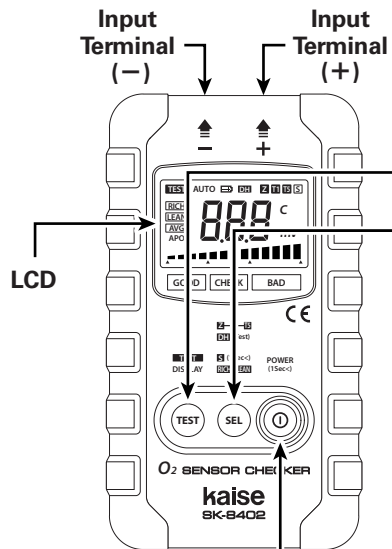

TEST Key

- ① Press this key for 1 second or more to start the normal test.
- ② Press this key for 2 seconds or more to finish the normal test.
- ③ Press this key less than 1 second to change the display mode during the normal test. (this function is available when "DH" lights up)
- ④ Press this key to output simulated signal in the simulation test mode.

SEL Key (SELECT Key)

- ① In stand-by mode... Press this key less than 1 second to select the types of O2 sensor.
- ② In stand-by mode... Press this key for 1 second or more to change testing mode (normal test or simulation test).
- ③ In simulation test... Press this key less than 1 second to change RICH test or LEAN test.

④ Display Hold

Press this key less than 1 second during normal test mode to hold display value on LCD. ("DH" lights up)

To Cancel : Press SEL Key for 1 second or more.

POWER Key

- ① Press this key for 1 second or more to turn on/turn off the unit.

Auto Power Off (this function is activated in default setting)

Power turns off automatically after approx. 20 minutes of the last key operation.

Note : Less than 2 μ A is consumed even in the power off condition.

To cancel : Turn on the unit holding down SEL Key. ("APO" disappears from LCD)

SPECIFICATIONS

1. General Specifications

1. OPERATING PRINCIPLE	$\Delta\Sigma$ Conversion
2. TEST METHOD	Input voltage calculation by microprocessor
3. SAMPLING RATE	500 times/second (LCD : 1 time/second in stand-by mode)
4. DISPLAY (LCD)	a. Numerical Display: LCD 999 count, 13 segment bar graph b. Units and Symbols: TEST, AUTO, E , DH, Z, T1, T5, S, RICH, LEAN, AVG, APO, C, m, V, ▲
5. RESPONSE TIME	within 1 second (in stand-by mode)
6. RANGE SELECTION	Auto range (range-up)
7. OPERATING TEMPERATURE & HUMIDITY	0°C to 40°C, 80%RH or lower (in non-condensing)
8. STORAGE TEMPERATURE & HUMIDITY	-20°C to 60°C, 70%RH or lower (in non-condensing)
9. TEMPERATURE COEFFICIENT	Add $\times 0.01/^{\circ}\text{C}$ to the accuracy outside $23^{\circ}\text{C} \pm 5^{\circ}\text{C}$
10. OVERVOLTAGE INDICATION	"H" display on LCD when 6V or more is input (same display for overflow indication)
11. GROUNDING INDICATION	"- -" display on LCD when + side of input terminal is grounded (only in stand-by mode)
12. OPEN-INPUT INDICATION	"- -" display on LCD when input is less than threshold (same as grounding indication)
13. REVERSE CONNECTION WARNING	"Err" display on LCD when minus voltage is input between input terminals Err (error) : Indication of minus voltage input
14. OVER CURRENT PROTECTION	"OL" blinks on LCD and stop testing when over current is detected during the simulation test OL (Over Load) : Warning indication of over current input

SPECIFICATIONS

15. BATTERY WARNING	<p>☹ sign starts blinking when the battery voltage becomes at approx. 2.5V. Simulation test should be stopped when it is detected.</p> <p>☹ sign blinks on LCD at approx. 2.4V or less.</p>
16. POWER SUPPLY	1.5V R6P or LR6(AA) batteries × 2
17. DISPLAY HOLD	Hold LCD display by pressing SEL Key (effective in normal test mode)
18. AUTO POWER OFF	Power turns off automatically after approx. 20 minutes of the last key operation. (cancelable)
19. OPERATING POWER SUPPLY VOLTAGE	Approx. 2.5V or more and 3.6V or less
20. POWER CONSUMPTION	10mA or less in normal test mode (approx. 2 μ A or less in power-off mode)
21. MAXIMUM MOMENTARY POWER CONSUMPTION	300mVA MAX (in simulation test mode)
22. CONTINUOUS OPERATING TIME (in normal test mode)	Approx. 80 hours (manganese battery) Approx. 180 hours (alkaline battery)
23. DIELECTRIC STRENGTH	1.1kV 50Hz sine wave, for 1 minute (between circuit and case)
24. SAFETY LEVEL	CE marking approved. (IEC61010-1 CAT I 600V class2)
25. DIMENSION & WEIGHT (accessories are not included)	148(H)×83(W)×33(D)mm, approx. 220g

※Product specifications and appearance are subject to change without notice.

SPECIFICATIONS

2. Measurement Specifications

(23°C±5°C、80%RH or lower, in non-condensing)

Range	Accuracy	Resolution
999mV	0 to 200mV : ±1.5%rdg±10dgt 201 to 999mV : ±1.5%rdg±5dgt	1mV
6.00V	±1.5%rdg±5dgt	10mV

※The unit works as DC Voltage Meter (6V max.) before pressing TEST Key.

※Goes down to 999mV range at less than 95 count.

※Goes up to 6V range at 1000 count or more in 999mV range.

※Threshold value of "--" display : within ±50mV input.
(in stand-by mode)

※Threshold value of "Err" display : -51mV input or less.

3. LCD Specifications

(23°C±5°C、80%RH or lower, in non-condensing)

Measurement displays (testing sign : TEST)

①RICH display : Maximum value of O2 sensor output for 10 seconds intervals with "RICH" sign.

②LEAN display: Minimum value of O2 sensor output for 10 seconds intervals with "LEAN" sign.

③AVG display: Average value of O2 sensor output for 10 seconds intervals with "AVG" sign.

④Cycle display: cycle variability numbers between RICH and LEAN of O2 sensor for 1 second.

Range	Accuracy	Resolution	Max. effective input
10.0C	±1%rdg±2dgt (from 0.2C)	0.1C	10.0C

※"--" display when the cycle value is unable to be measured.

※"OL" display when the input exceeds the maximum effective input value.

OL (Over Load) : Warning indication of over input

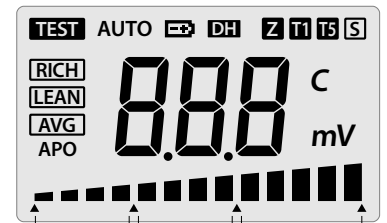

GOOD (No problem) **CHECK** (Replacement recommended) **BAD** (Replacement required)

TEST : Lights up when the test is activated

AUTO : Lights up when auto display mode is selected

☹ : Blinks in low battery voltage

DH : Lights up in display hold function

Z : Lights up when Zirconia sensor is selected

T1 : Lights up when Titania 1V sensor is selected

SPECIFICATIONS

- T5** : Lights up when Titania 5V sensor is selected
- S** : Lights up when simulation test mode is selected
- RICH** : Lights up or blinks when RICH voltage is displayed or RICH voltage output is selected
- LEAN** : Lights up or blinks when LEAN voltage is displayed or LEAN voltage output is selected
- AVG** : Lights up when AVG voltage is displayed
- APO** : Lights up when auto power off is activated
- C** : Lights up when cycle display mode is selected
- m** : Auxiliary unit in voltage display (mV)
- V** : Unit of voltage display
- Bargraph** : Test result is shown as bar graph (lighting or blinking)
 - ▲ : Test result separator in bar graph

4. Simulation Test (testing sign: TEST)

● Zirconia & Titania 1V

(sensor impedance : 100Ω or more at 23°C Typ)

※Output following voltage by pressing TEST Key.

- ① RICH mode : 0.8V Min. to 1.3V Max.
- ② LEAN mode : approx. 0V

● Titania 5V

(sensor impedance : 500Ω or more at 23°C Typ)

※Output following voltage by pressing TEST Key.

- ① RICH mode : 4.7V Min. to 5.3V Max.
- ② LEAN mode : approx. 0V

● LCD display

- ① In RICH test : **RICH** blinks.
- ② In LEAN test : **LEAN** blinks.
- 3 seconds signal output for each test.
- 3 seconds interval is necessary for each test. Continuous testing is not possible.
- Simulation test should be stopped and changed into stand-by mode when battery voltage becomes 2.5V or less.
- Simulation test mode is not activated when the battery voltage becomes 2.5V or less.
- Simulation test mode is not activated when the test voltage in stand-by mode is lower than the threshold ("Err" display).
- Simulation test mode is not activated when the test voltage in stand-by mode is higher than the threshold ("H" display).
- Simulation test is stopped and "OL" blinks on LCD when the over current is detected.
- OL (Over Load) : Warning indication of over current input
- Sensor Impedance of detected threshold
 - Zirconia and Titania 1V sensor : sensor impedance approx. 100Ω or less 23°C Typ
 - Titania 5V sensor : sensor impedance approx. 500Ω or less 23°C Typ
- The unit cannot be turned off during the simulation test.

BEFORE USE

1. Types of O2 Sensors

Correct knowledge about the O2 sensor types are necessary to use this instrument properly.

This instrument is suitable for deterioration check for zirconia O2 sensor and titania 1V/5V O2 sensors.

Confirm the type of the target O2 sensor with your own vehicle maintenance manual.

Zirconia O2 Sensor

Zirconia O2 Sensor was launched to clean the exhaust gas of the car, efficiency was improved year by year, and it is the most typical sensor type now. Zirconia O2 Sensor generates electricity by itself and provides an output voltage corresponding to a quantity of residual oxygen in exhaust gas.

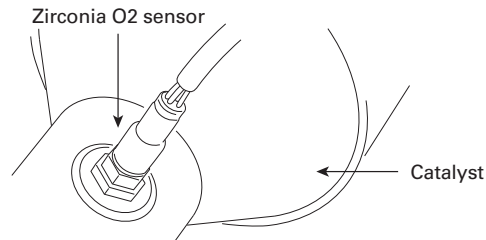

Titania O2 Sensor

Titania O2 sensor has two types: titania 1V O2 sensor and titania 5V O2 sensor. In the past, there was the car model that was equipped titania O2 sensor instead of zirconia O2 sensor, but it is not popular now. The resistance value of titania O2 sensor is changed corresponding to a quantity of residual oxygen in exhaust gas, therefore supplying external power supply voltage is necessary for titania sensor to obtain the output signal.

This instrument cannot display the deterioration level of A/F (air-fuel ratio) sensor on bar graph.

● A/F (air-fuel ratio) sensor :

A/F sensor tends to be equipped to fuel-efficient car or low exhaust car recently. O2 sensor can recognize only a change of signal between "rich mixture" (low in remaining oxygen) and "lean mixture" (high in remaining oxygen), but A/F sensor can output the fluctuating signal of A/F linearly every moment.

The number of wiring for the dual cell type A/F sensor is five or more.

This instrument cannot display the deterioration level of Rear O2 Sensor on bar graph.

● Rear O2 Sensor :

Rear O2 Sensor is equipped behind the catalyst to check the condition of 3-way catalyst. Sensor in itself is the same as O2 sensor equipped in manifold side, but the waveform of output signal is different. If the measurement result of rear O2 sensor and manifold side O2 sensor are almost the same, the exhaust gas would not be purified by 3-way catalyst and there would be some problems in the exhaust system.

BEFORE USE

2. Battery Installation

WARNING

- To prevent electric shock, detach the instrument from the measuring object and turn it off before installing or replacing the battery.
- To prevent electric shock, do not replace the battery with wet hands.

CAUTION

- Do not use any battery that have wrong rated specification. It may cause any accidents due to explosion or leakage.
- Install the battery with the correct polarity as shown in the plus⊕ and minus⊖ indications. Installing battery with wrong polarity may cause any accidents due to explosion or leakage.
- To prevent any accidents, dispose the exhausted battery in accordance with the local government rule after applying adhesive tape to both electrodes for insulation.
- Do not heat or disassemble the battery. Do not put them into the fire or water. It may cause any accidents due to explosion or leakage.

Install attached batteries before using the instrument.

- ① Loosen a screw of battery cover and open it. Then, insert attached 2 pcs of batteries with the correct polarity as shown in the plus⊕ and minus⊖ indications.

NOTE : Pull the screw when the battery cover is hard to be opened.

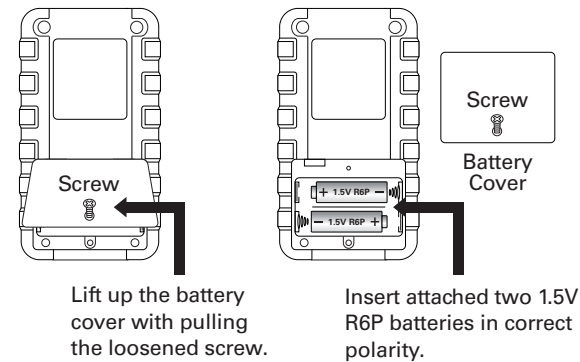

- ② Fix battery cover and tighten up a screw.

BEFORE USE

3. Confirmation of O2 Sensor Cables

Types and Numbers of Zirconia O2 Sensor Cables

- ① O2 sensor without heater : 1 cable
(sensor signal cable)
- ② O2 sensor without heater : 2 cables
(sensor signal cable, sensor earthing cable)
- ③ O2 sensor with heater : 3 cables
(sensor signal cable, heater cable x 2 [same color])
- ④ O2 sensor with heater : 4 cables
(sensor signal cable, sensor earthing cable, heater cable x 2 [same color])

Types and Numbers of Titania O2 Sensor Cables

- ① 3 cables
(sensor signal cable, earthing cable, power supply cable)

WARNING

O2 sensor is equipped nearby the engine exhaust part where should have very high temperature. Do not start the measurement just after the engine stopped and wait until it is cooled down.

CAUTION

Error code is memorized in ECU when taking off the connector of O2 sensor with the engine is running and the electric car components are activated. Delete the error code by using the Code Reader to prevent any engine troubles.

4. Colors of O2 Sensor Cables

※Cable colors between O2 sensor and the connector.
Not the cable colors of ECU side connector.

Zirconia O2 sensor

	Sensor signal cable (+)	Sensor earthing cable (-)	Heater cable (2 cables)
Example 1	Black	Gray	White
Example 2	Purple	Light Brown	Dark Brown
Example 3	Blue	White	Black
Example 4	White	Green	Black

●Harness cable colors of Example 1 in the table above

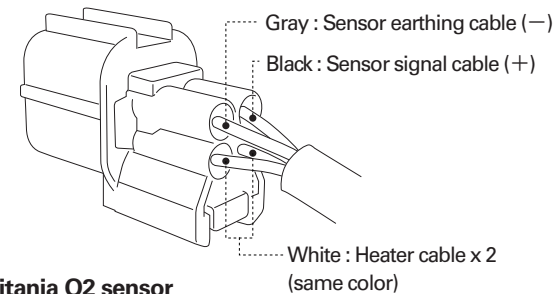

Titania O2 sensor

	Sensor signal cable (+)	Earthing cable (-)	Power supply cable
Example 1	Black	White	Red

PREPARATION FOR USE

1. Inspection of Check Harness and Test Lead

Inspect whether test lead and check harness are not disconnected in accordance with the following procedures.

●Inspection for Test Lead

- ① Connect red and black L-shaped plugs of the test lead to red (+) and black (-) input terminals.
- ② Connect red and black test pins to the red and black straight plugs respectively.

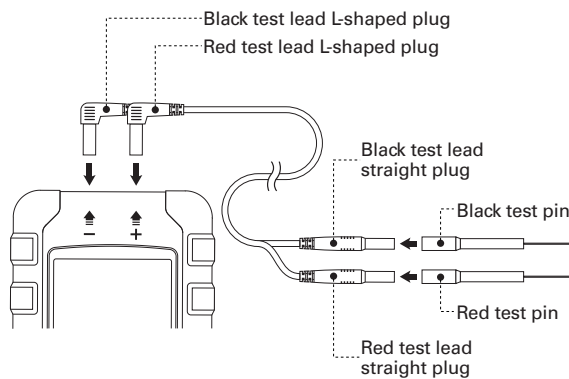

- ③ Press POWER Key for 1 second or more to turn on the instrument. It enters stand-by mode for cable connection check.
- ④ Press SEL Key for 1 second or more to enter simulation test mode for zirconia O₂ sensor.
5 lights up on LCD.

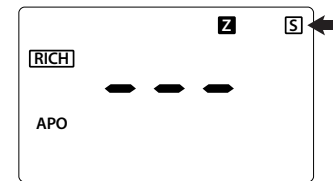

- ⑤ Press TEST Key for 1 second or less with short-circuiting red and black test pins to output RICH signal.

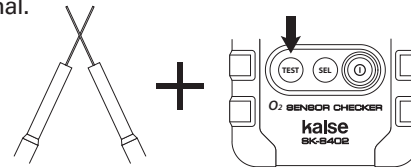

Press TEST Key for 1 second or less with contacting the tips of red and black test pins.

PREPARATION FOR USE

- ⑥ Test lead wires have good continuity if "OL" blinks on LCD. Otherwise, they should be disconnected. This concludes the test lead inspection.

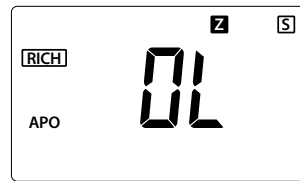

● Inspection for Check Harness

- ① Connect red and black L-shaped plugs of the test lead to red (+) and black (-) input terminals.
- ② Connect red and black check harness connecting plugs to the red and black straight plugs respectively.

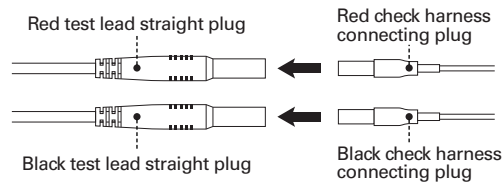

- ③ Press POWER Key for 1 second or more to turn on the instrument. It enters stand-by mode for cable connection check.
- ④ Press SEL Key for 1 second or more to enter simulation test mode for zirconia O2 sensor. **S** lights up on LCD.

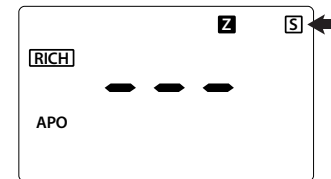

- ⑤ Short-circuit red and black male connecting terminals and press TEST Key for 1 second or less to output RICH signal.

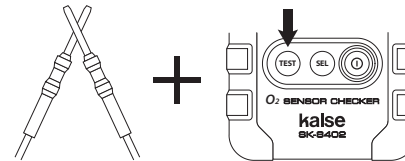

Press TEST Key for 1 second or less with contacting the tips of red and black male connecting terminals.

PREPARATION FOR USE

- ⑥ Red and black check harnesses have good continuity if "OL" blinks on LCD. Otherwise, either or both of them should be disconnected.

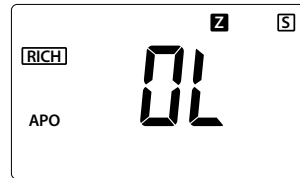

- ⑦ Press SEL Key for 1 second or more to finish simulation test mode temporarily. Press SEL Key again for 1 second or more and enter simulation test mode once again.
- ⑧ Connect two yellow check harness connecting plugs to the red and black straight plugs respectively.

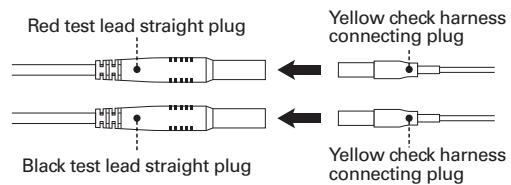

- ⑨ Short-circuit two yellow male connecting terminals and press TEST Key for 1 second or less to output RICH signal.

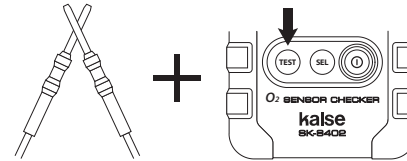

Press TEST Key for 1 second or less with contacting the tips of two yellow male connecting terminals.

- ⑩ Two yellow check harnesses have good continuity if "OL" blinks on LCD. Otherwise, either or both of them should be disconnected. This concludes the check harness inspection.

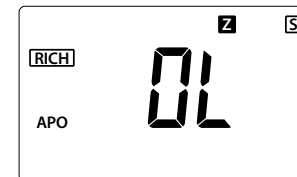

PREPARATION FOR USE

2. Check Harness Connection

Connect check harnesses in accordance with the following procedures after checking the type of O2 sensor.

- ① Confirm that the engine is completely stopped.
(Turn off the engine and electric components)
- ② Detach connecting couplers of O2 sensor and ECU.

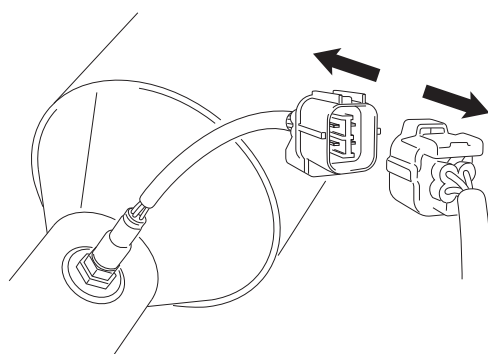

- ③ Connect the couplers of ECU and O2 sensor with check harnesses.

Signal cables in the couplers should be connected as follows;

- Sensor signal cable → red cable of check harness
- Sensor earthing cable → black cable of check harness
- Heater cables (two) → yellow cables of check harness

Check point

- The colors of signal cables of O2 sensor and ECU are not the same. Confirm the connecting direction of the couplers and connect the proper cables with check harnesses. After connecting check harnesses, confirm whether cables are connected correctly.
- If the couplers cannot be connected by check harness, use test pins (red and black) instead. Refer to the contents of "Measurement Procedure with Test Pin" in page 32.

PREPARATION FOR USE

Example of check harness connection for "zirconia O2 sensor, example 1" in page 17

Connecting coupler for O2 sensor side

- Connect female connecting terminal of check harness.

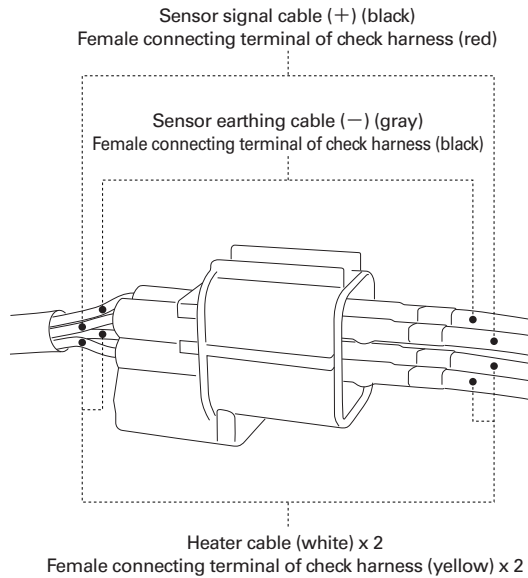

Connecting coupler for ECU side

- Connect male connecting terminal of check harness.
- ※ Set the connecting couplers in the same direction and connect the originally connected pins with the same colored check harnesses as the female connecting terminals.

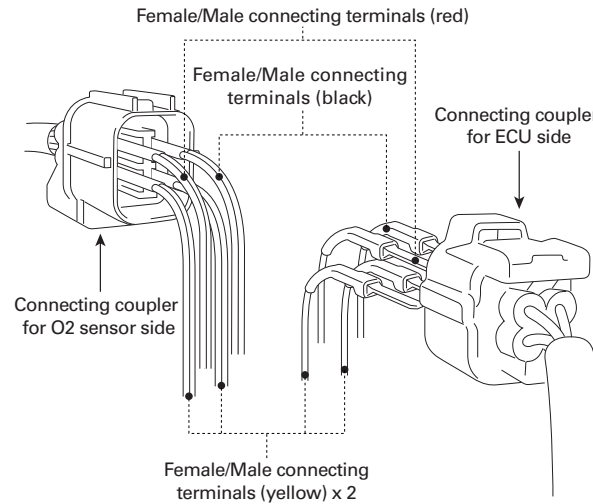

BASIC CONNECTION DIAGRAM

Connection image of zirconia O2 sensor with 4 cables

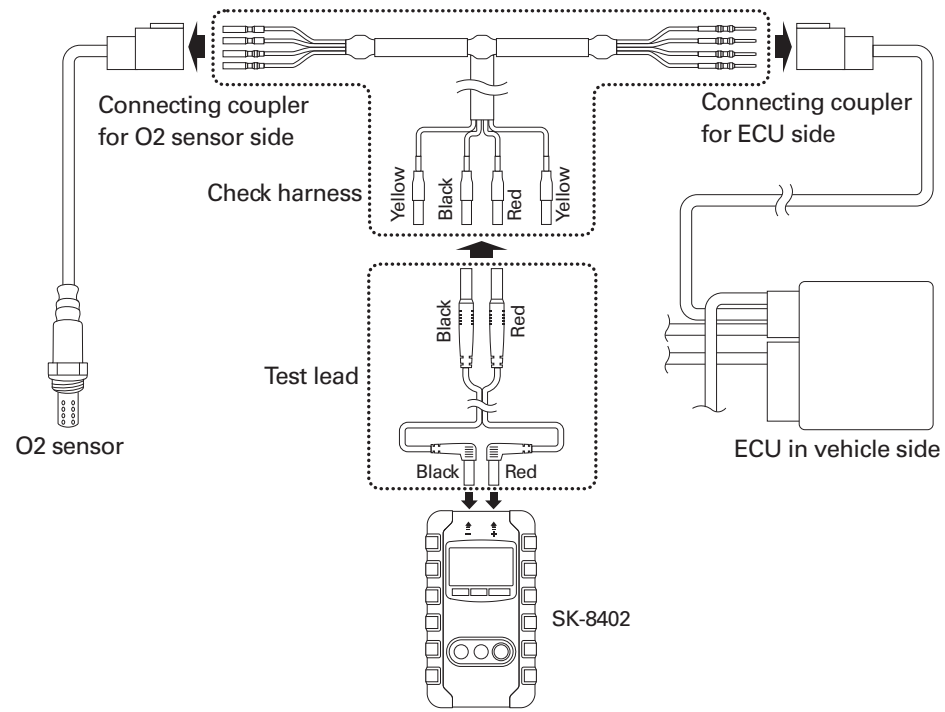

NORMAL TEST

1. Measurement Flow Chart

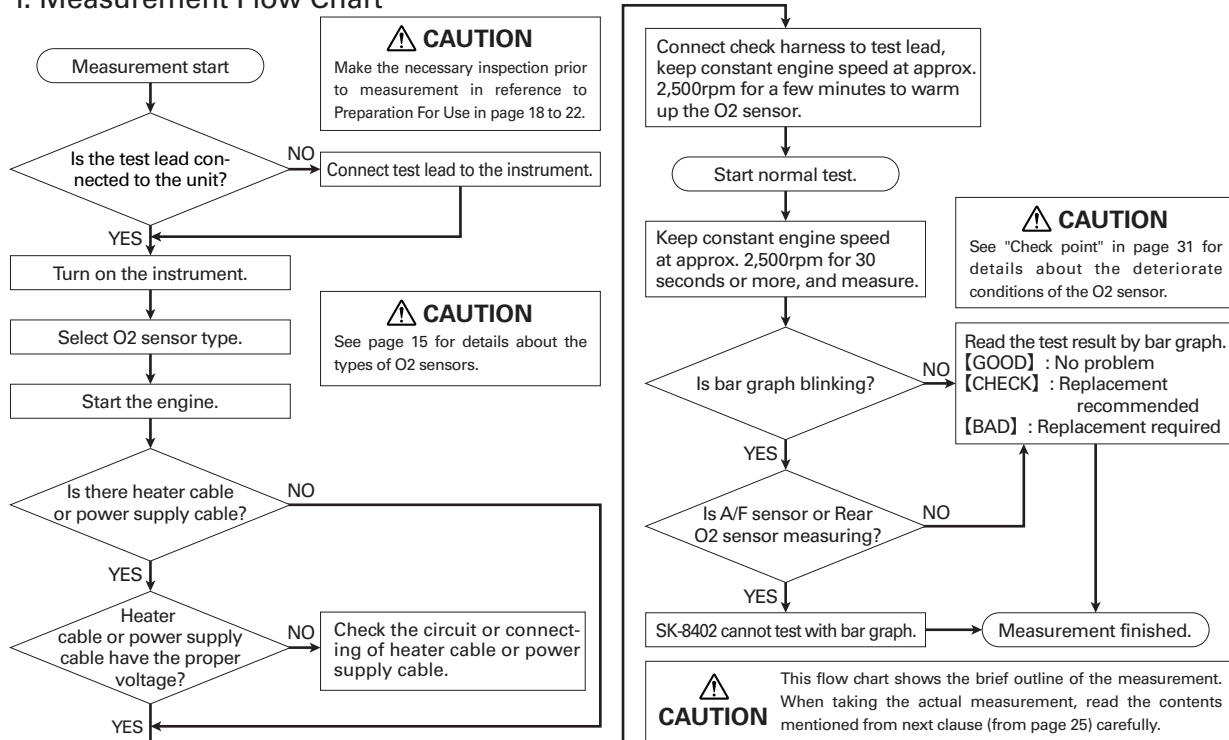

NORMAL TEST

2. Measurement Procedure with Check Harness

- ① Connect red and black L-shaped plugs of the test lead to red (+) and black (-) input terminals respectively.

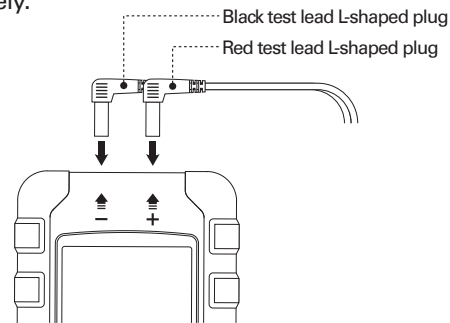

- ② Press POWER Key for 1 second or more to turn on the instrument. It enters stand-by mode for cable connection check.

※LCD display might be drifting when connecting the test leads or the cables due to the high input impedance of this instrument, but does not affect the measurement.

- ③ Press SEL Key for 1 second or less and select the type of O₂ sensor to be measured. Default setting is zirconia O₂ sensor.

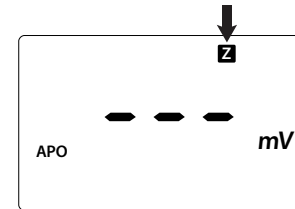

Check point

Titania O₂ sensor always has power supply cable (red). Confirm it when selecting.

NORMAL TEST

④ Start the engine.

WARNING

- Do not touch the engine which has high temperature. Be careful about the cables not to touch the heated metal part.
- Stay away from the rotating part of the engine which is very dangerous to be caught in. Also, be careful about the cables not to be caught in.
- Start the engine under well ventilated environment to prevent carbon monoxide poisoning.

⑤ If the zirconia O₂ sensor to be measured has heater cables, make their voltage check. When measuring titania O₂ sensor, make voltage check of its power supply cable.

- ※ Zirconia O₂ sensor cannot output the correct signal if heater is not working properly.
- ※ Titania O₂ sensor cannot output the signal if the power supply voltage is not supplied.

Only for the heater of zirconia O₂ sensor, disconnection check for the heater cable is possible by simulation test. See "Disconnection check of the heater cable" in page 36 to 38 for details.

Checks of the heater cable voltage (when available)

Connect two yellow check harness connecting plugs to the red and black straight plugs respectively.

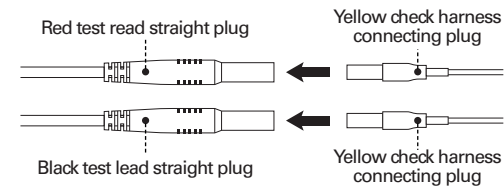

LCD displays "H" if the heater cable has the proper voltage at 6V or more.

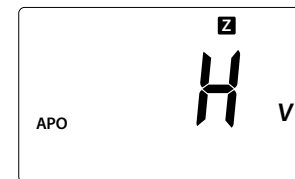

※ The heater cable has the sufficient voltage even if "H" display is unstable when checking the heater cable with PWM control.

NORMAL TEST

If LCD displays "Err", change the connection of two yellow check harness connecting plugs and the red and black straight plugs the in reverse.

Heater voltage is good if LCD displays "H".

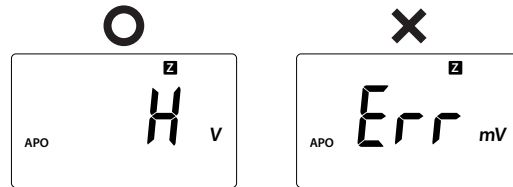

Meanings of LCD display in stand-by mode

" --- "		Test leads are opened, grounded or input voltage is within $\pm 50\text{mV}$.
" H "		$\pm 6\text{V}$ or more is measured.
" Err "		Minus voltage is measured, such as reverse connection or when back electromotive force is generated.

Checks of the power supply cable voltage (when available)

● Connection of Titania O2 Sensor

Connect sensor signal cable to red, earthing cable to black, and power supply cable to yellow check harness connecting plugs respectively.

Attach alligator clip to black test lead straight plug and fix it to the metal frame part of the car or minus terminal of battery for earthing.

Connect red test lead straight plug to yellow check harness connecting plug.

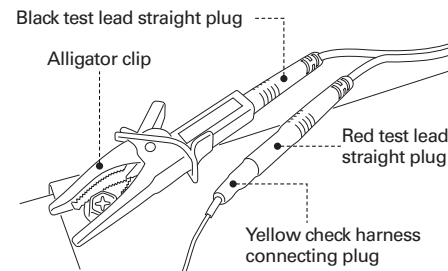

NORMAL TEST

When the proper power supply voltage is supplied, LCD displays approx. 1V for titania 1V O2 sensor and approx. 5V for titania 5V O2 sensor.

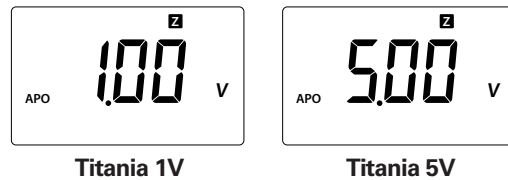

※Change the setting of O2 sensor type into the correct one if necessary.

⑥Connect red and black check harness connecting plugs to the red and black straight plugs respectively.

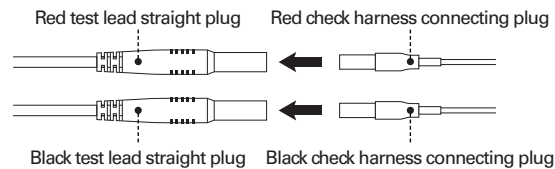

※If the O2 sensor to be measured has only 1 or 3 cables, attach alligator clip to black test lead straight plug and fix it to the metal frame part of the car or minus terminal of battery for earthing.

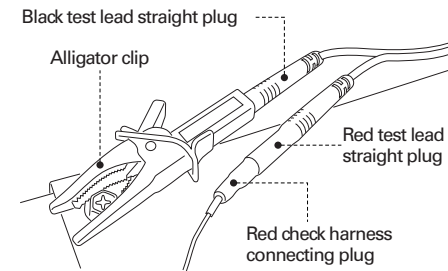

⑦Keep constant engine speed at approx. 2,500rpm for 3 to 4 minutes to warm up the O2 sensor. O2 sensor is unable to output the correct signal unless its temperature reaches the certain level. When measuring the car without tachometer, estimate the engine speed by its sound with stepping on the accelerator pedal lightly.

NORMAL TEST

WARNING

To prevent any accident, carefully check the gear position, surrounding situation, and whether parking brake is applied when stepping on the accelerator pedal.

※LCD displays "Err" continuously if the sensor signal cable and sensor earthing cable are connected in reverse. In this case, change the connection of test leads to input terminals of SK-8402 in reverse, red to (-) terminal and black to (+) terminal.

When changing the connection, stop the engine completely and turn the ignition key switch to OFF position.

Continue the measurement when the connecting is correct.

※If LCD keeps on displaying "---", confirm the check harness connection between O2 sensor and ECU connecting coupler. Continue the measurement if they are connected correctly.

⑧ Press TEST Key for 1 second or more and start O2 sensor test.

TEST and bar graph are displayed on LCD.

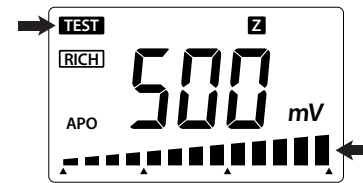

(example)

Continue the measurement even if the bar graph blinks just after starting O2 sensor test. Deterioration check can be made in the next measurement step.

NORMAL TEST

⑨ **Keep the engine speed at approx. 2,500rpm.** When measuring the car without tachometer, estimate the engine speed by its sound. Bar graph becomes stable and shows the deterioration level of O2 sensor **after keeping the engine speed for 30 seconds or more.**

※SK-8402 cannot display the deterioration levels of A/F (air-fuel ratio) sensor and rear O2 sensor that is equipped behind the catalyst to check the condition of 3-way catalyst.

※When measuring the above types of O2 sensors, bar graph blinks to alert the user. If the bar graph keeps blinking during the normal test, confirm the sensor equipped on vehicle is not A/F (air-fuel ratio) sensor or not measuring the rear O2 sensor.

When measuring the O2 sensor that is equipped on the manifold side, bar graph displays the actual test result.

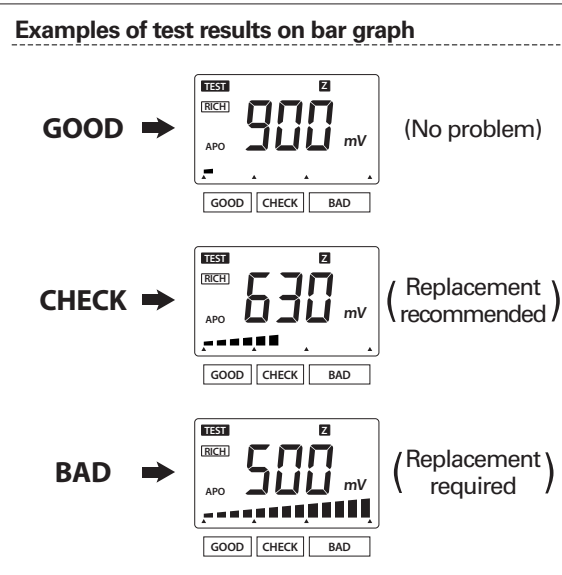

NORMAL TEST

Check point

- RICH voltage drops down when O2 sensor deteriorates.
- LEAN voltage changes upper and lower than the standard LEAN voltage, and cycling speed decreases.
- O2 sensor may be deteriorated if bar graph blinks with extremely low RICH, LEAN and AVG voltages and no cycle measurement.
- When measuring A/F sensor or rear O2 sensor, RICH, LEAN and AVG voltages becomes almost the same. Cycle cannot be measured.

- ⑩ Press TEST Key for 2 seconds or more to finish normal test.
- ⑪ Stop the engine and turn off the ignition key switch.
- ⑫ Press POWER Key for 1 second or more to turn off the instrument.
- ⑬ Remove check harness and test lead from the connecting couplers of O2 sensor and ECU.
- ⑭ Fix the connection of the connecting couplers of O2 sensor and ECU and finish the normal test.

Available functions

Display mode changing

- Press TEST Key for 1 second or less.
RICH → LEAN → AVG → Cycle → AUTO → RICH
※ In AUTO, display is changed automatically at 3 seconds intervals. (RICH → LEAN → AVG → RICH)

Display hold

- Press SEL Key for 1 second or less during the normal test to hold the display. (**DH** lights up)
To release it : Press SEL Key again for 1 second or more. (**DH** is disappeared)
※ Display mode can be changed in display hold function.

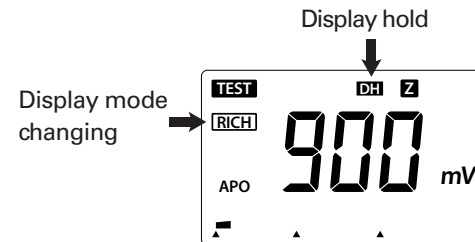

NORMAL TEST

3. Measurement Procedure with Test Pin

● Testing procedure when O2 sensor and ECU cannot be connected by check harness

- ① Connect red test pin to red test lead straight plug.
- ② Connect alligator clip to black test lead straight plug.
- ③ Fix alligator clip to the metal frame part of the car or minus terminal of battery for earthing.

※LCD display might be drifting when connecting the test leads or the cables due to the high input impedance of this instrument, but does not affect the measurement.

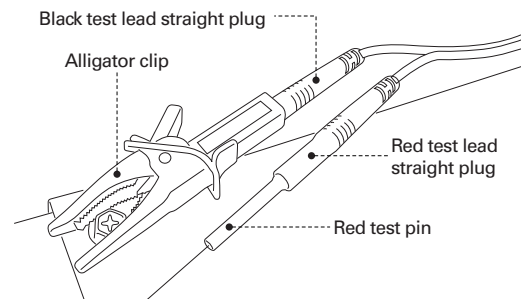

- ④ Insert red test pin to the space of sensor signal cable from the backside of connecting couplers of O2 sensor or ECU (see "Confirmation of O2 Sensor Cables" and "Colors of O2 Sensor Cables" in page 17). Test procedures are the same as when using the check harness.

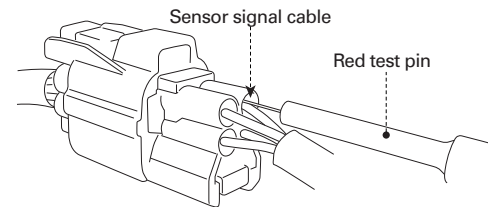

- ※Insert test pin deeply to have a enough continuity.
- ※If "----" remains displayed when checking the heater cable voltage, insert test pin into another heater cable. If LCD still displays "----", cable disconnection, or blowout of a fuse that is mounted on vehicle may occur.

NORMAL TEST

⑤ If the O2 sensor to be measured has only 2 or 4 cables, attach black test pin to black straight plug instead of alligator clip, and insert it to the space of sensor earthing cable after confirming the sensor signal by inserting red test pin to the space of sensor signal cable (see "Confirmation of O2 Sensor Cables" and "Colors of O2 Sensor Cables" in page 17). Start the test after confirming the signals.

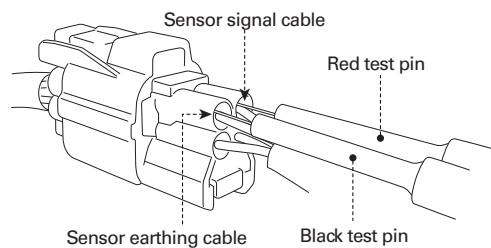

● Maintenance of connecting coupler

Measurement by using the Test Pin might weaken the waterproof property of the connectors of O2 sensor and ECU. Wrap heat-resistance/waterproof tape around them after taking the measurement.

SIMULATION TEST

What is simulation test?

Simulation test is the function that outputs the simulated sensor signal from SK-8402 and check various defects of O2 sensor and ECU. In combination with a scanning tool that can monitor the control condition of ECU or sensor signal waveform, various checking are possible such as control condition of ECU, connecting defects of cable connections of O2 sensor and ECU, or O2 sensor troubles.

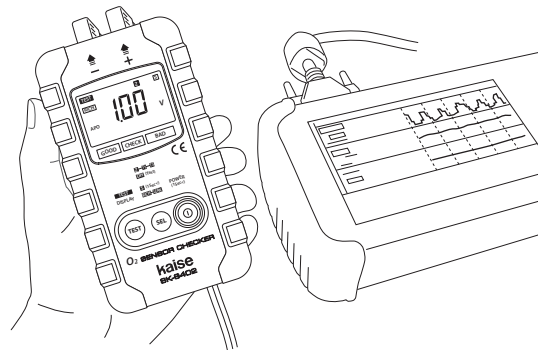

- ※Simulation test cannot be made for A/F (air-fuel ratio) sensor.
- ※Connect O2 sensor and ECU properly with check harness before starting the simulation test.
- ※An error code might be memorized in ECU and warning lamp may lights up when simulation test is made for rear O2 sensor.

CAUTION

Do not make the simulation test for other purposes except for the checking O2 sensor circuit and this instrument.

- ① Connect the connecting couplers of O2 sensor and ECU properly with check harness.
- ② Make the O2 sensor test in reference to "Normal Test" in page 24 to 33.
- ③ If the sensor type is not sure by a process to the above, select the zirconia O2 sensor.
 - ※To select the type of O2 sensor, press SEL Key for 1 second or less in stand-by mode. (default setting is zirconia O2 sensor)

SIMULATION TEST

⚠ CAUTION

Do not apply the simulation test for titania 5V O2 sensor to zirconia O2 sensor or titania 1V O2 sensor. It may damage the O2 sensor and ECU.

- ④ Connect red and black check harness connecting plugs to the red and black straight plugs respectively.

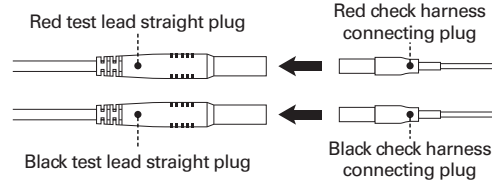

⚠ CAUTION

Do not take the simulation test for heater cable or power supply cable during the electric car components are activated. It may damage to the instrument.

- ⑤ Press SEL Key for 1 second or more in stand-by mode to enter simulation test mode. **S** lights up on LCD.

※ Confirm the selected O2 sensor type displayed on LCD.

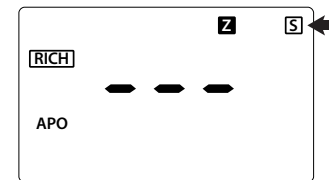

- ⑥ Press SEL Key for 1 second or less in simulation test mode to select RICH signal output or LEAN signal output.

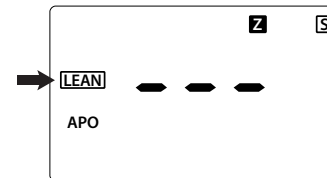

SIMULATION TEST

- ⑦ Press TEST Key for 1 second or less. The instrument outputs RICH or LEAN simulation signals for 3 seconds with **TEST** sign on LCD. 3 seconds interval is necessary for next signal output.

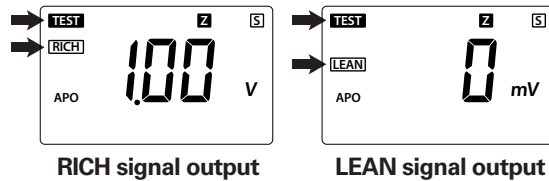

- ※Checking control conditions of ECU and changes of output waveform from O2 sensor are effective for detecting cable connection error, O2 sensor error or ECU error.
- ※When "OL" blinks on LCD during the simulation test, O2 sensor error, cable connection error or lower O2 sensor impedance than the threshold may occur.

- Example 1 : Trouble of O2 sensor (internal short circuit)
- Example 2 : Short circuit of the cable connection
- Example 3 : Internal impedance of the O2 sensor becomes lower than the threshold of simulation test. (There is no problem when O2 sensor works normally)

※To stop the "OL" blinking, turn off the instrument or finish the simulation test.

- ⑧ Press SEL Key for 1 second or more to close simulation test mode and to enter the stand-by mode.
- ⑨ When finishing the simulation test, follow the procedures described from ⑩ to ⑭ in page 31.

SIMULATION TEST

Disconnection check for the O2 sensor heater

Disconnection check for the O2 sensor heater is possible by simulation test.

※Only for the heater of zirconia O2 sensor,

- ① Confirm that the engine is completely stopped.
(Turn off the engine and electric components)
- ② Detach connecting couplers of O2 sensor and ECU.
- ③ Connect two female connecting terminals (yellow) to heater cables of connecting coupler in O2 sensor side.
- ④ Connect red and black L-shaped plugs of the test lead to red (+) and black (-) input terminals respectively.

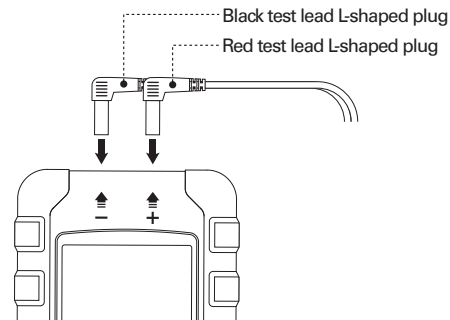

- ⑤ Connect two yellow check harness connecting plugs to the red and black straight plugs respectively.

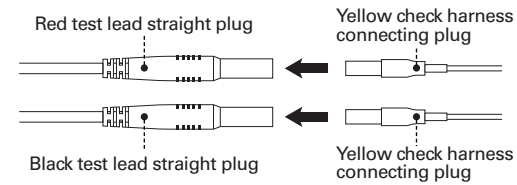

- ⑥ Press POWER Key for 1 second or more to turn on the instrument. It enters stand-by mode for cable connection check.
- ⑦ Press SEL Key for 1 second or more to enter simulation test mode for zirconia O2 sensor.
[5] lights up on LCD.
- ⑧ Press TEST Key for 1 second or less to output RICH signal.

※When the engine was running until just before connection checking of the O2 sensor heater, test it after waiting until it is cooled down. Because the resistance of the heater is increased due to the high temperature.

SIMULATION TEST

- ⑨The heater of O2 sensor has good continuity if "OL" blinks on LCD. Otherwise, it should be disconnected.

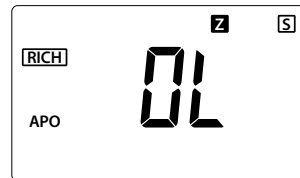

- ⑨This concludes the disconnection check for O2 sensor heater.

MAINTENANCE

1. Battery Replacement

Replace the batteries in accordance with the following procedure when  blinks on LCD.

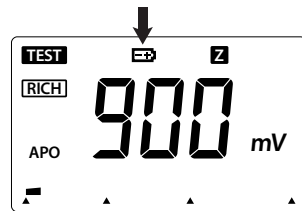

- ① Detach the instrument and the cables from the measuring object and turn off the instrument.
- ② Loosen a screw of battery cover and open it. Then, remove the exhausted batteries.
NOTE : Pull the screw when the battery cover is hard to be opened.
- ③ Insert 2 pcs of new 1.5V R6P (AA manganese) or LR6 (AA alkaline) in the correct polarity.

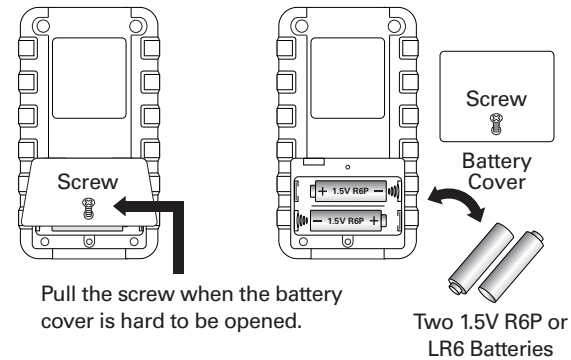

- ④ Fix battery cover and tighten up the screw.

2. Periodical Check and Calibration

Periodical check and calibration is necessary to make safety measurements and to maintain the specified accuracy. The recommended check and calibration term is once a year and after the repair service. This service is available at KAISE AUTHORIZED SERVICE AGENCY through your local dealer.

TROUBLE SHOOTING

If there are any failure with this instrument, check the following trouble shoots before asking repair service. Ask KAISE AUTHORIZED SERVICE AGENCY through your local dealer when there are any questions or troubles with this instrument.

Symptoms	Possible Causes and Necessary Treatments
Cannot turn on the instrument	<ul style="list-style-type: none">● Batteries are exhausted. → Replace the batteries.● Batteries are installed in the wrong polarity. → Install the batteries in the correct polarity.● Pressing time of the POWER Key is too short or not enough. → Press POWER Key for 1 second or more.
Displayed value is unstable	<ul style="list-style-type: none">● The temperature of the O2 sensor is cooler than the certain temperature. → Warm up the O2 sensor keeping constant engine speed at approx. 2,500rpm for 3 or 4 minutes. Keep the engine speed at approx. 2,500rpm during the normal test.
LCD does not display the measurement value	<ul style="list-style-type: none">● Test lead or check harness are broken. → Inspect whether they are disconnected. (see page 18 to 20)● O2 sensor or the other parts are broken. → Make the same test with the other cars and check if the display still have the failure.

WARRANTY

WARRANTY

SK-8402 is warranted in its entirety against any defects of material or workmanship under normal use and service within a period of one year from the date of purchase of the original purchaser. Warranty service is available at **KAISE AUTHORIZED SERVICE AGENCY** through your local dealer. Their obligation under this warranty is limited to repairing or replacing SK-8402 returned intact or in warrantable defect with proof of purchase and transport charges prepaid. **KAISE AUTHORIZED DEALER** and the manufacturer, **KAISE CORPORATION**, shall not be liable for any consequential damages, loss or otherwise. The foregoing warranty is exclusive and in lieu of all other warranties including any warranty of merchantability, whether expressed or implied.

This warranty shall not apply to any instrument or other article of equipment which shall have been repaired or altered outside of **KAISE AUTHORIZED SERVICE AGENCY**, nor which have been subject to misuse, negligence, accident, incorrect repair by users, or any installation or use not in accordance with instructions provided by the manufacturer.

KAISE AUTHORIZED DEALER

KAISE CORPORATION

422 Hayashinogo, Ueda City, Nagano Pref., 386-0156 Japan
TEL : +81-268-35-1600 (REP.) / FAX : +81-268-35-1603
E-mail : sales@kaise.com <http://www.kaise.com>

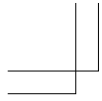

SK-8402 取扱説明書 (英文) 表4

