



*Motor Measurement,
from Performance Analysis
to Quality Testing*

Measurement Application Profile

Improving Motor Performance and Quality

High-Precision Measurement Solutions

Hioki offers a diverse array of motor measurement solutions that can be used in applications ranging from performance analysis to quality testing. The ability to assess and analyze using high-precision measurement technologies provides valuable assistance to engineers as they work to increase motor performance and quality.

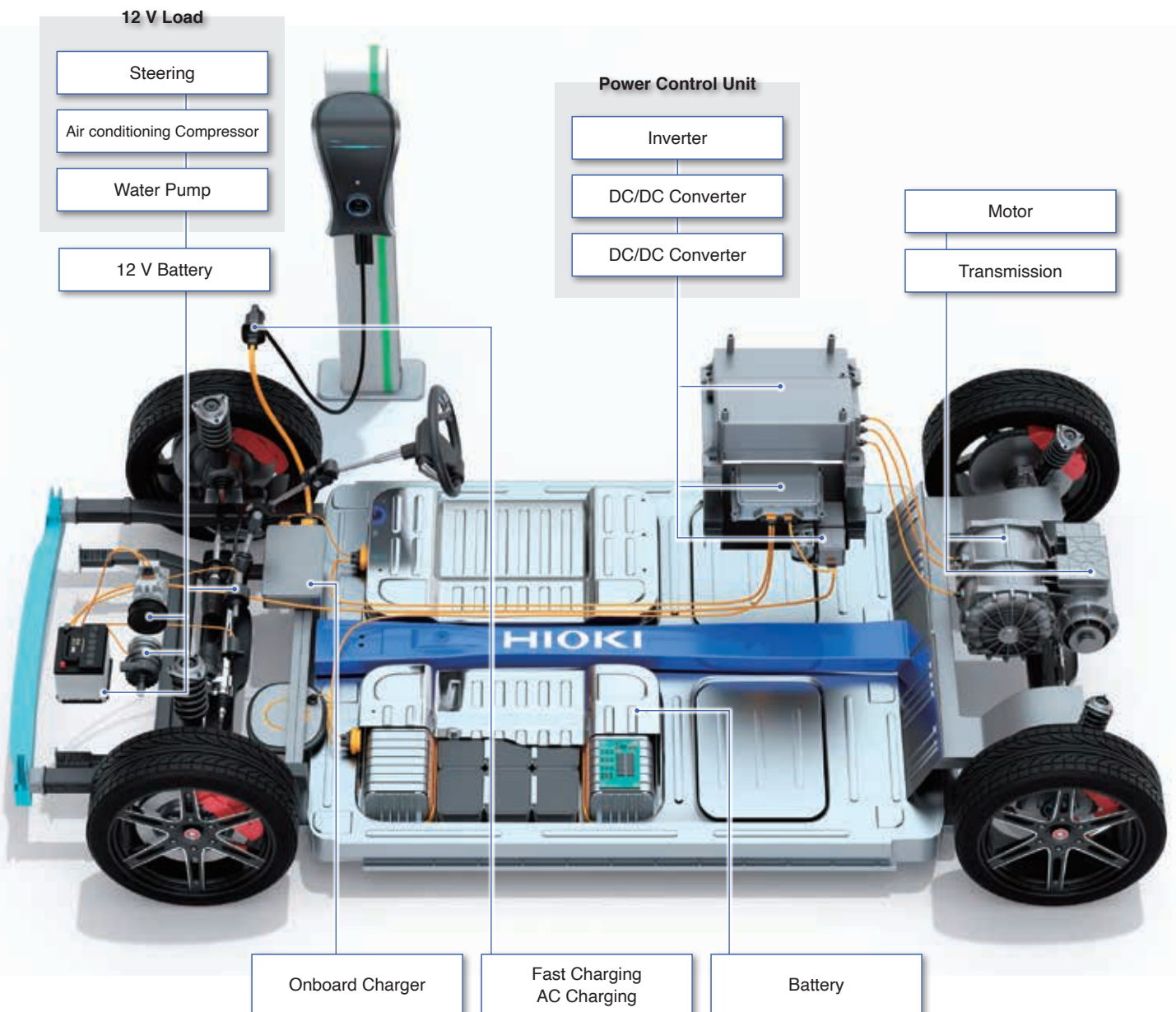

Design / Development

Evaluating Inverter Motor Efficiency and Loss

Page 4

Simultaneously measure inverter input and output power, and motor output. Evaluate inverter, motor, and overall system efficiency and loss in an accurate and highly reproducible manner.

Inverter Motor ECU Measurement and Calibration

Page 5

Make quick work of PCU calibration by taking advantage of PW6001 and INCA^{*1} link functionality so that you can use the PW6001 to perform accurate power and motive power measurement. You can simultaneously monitor CAN bus data and ECU RAM values.

Identifying PMSM Motor Parameters

Page 6

Identify more accurate motor control motor control by using motor parameters measured under actual operating conditions in upstream design processes.

Test Automobile Fuel Economy

Page 7

Taking fuel economy measurements that comply with WLTP international standards requires the precise measurement of current integration and power integration for the recharging/discharging of each battery in the system. High accuracy clamp current sensors, the excellent DC accuracy of the PW3390, and the ability to integrate current and power at 50 ms intervals are extremely effective in meeting this application.

Measuring Motor Temperature

Page 8

Apply thermocouples to the motor frame and winding to record temperature variations. Display and record differences in temperature relative to the measurement environment as a waveform in real time.

EV and EV Motor Evaluation Using CAN/CAN FD

Page 9

Accurately assess behavior during HILS testing and vehicle evaluation by simultaneously measuring control and sensor data on the CAN bus and actual analog values.

Measuring Dynamic Motor Characteristics

Page 10

Record inverter output voltage and current, torque, and RPM from motor start to stop. Calculate inverter output power, motor power, and motor efficiency using waveform calculations.

Measuring Motor Torque Vibrations

Page 11

Measure torque and vibration, and analyze behavior during motor operation. Discover resonance phenomena and other unpredicted frequency components by using FFT calculations to perform a frequency analysis.

Measuring Resolver Rotation Angles

Page 12

Record the resolver rotor excitation and output signal, and calculate the rotation angle using waveform calculation functionality. Verify motor control sequences by analyzing the relationship between the resolver rotation angle and other signals.

Production / Testing

Performing Layer Short Testing of Motor Windings

Page 13

Detect insulation failures (layer shorts) and deterioration in motor windings. Generate pass/fail judgments with greater precision than conventional approaches by quantifying response waveforms.

Performing Motor Winding Maintenance

Page 14

Perform impulse testing and use the results in motor winding maintenance and trend management.

Observation of Partial Discharges During Breakdown Voltage Testing

Page 15

Detect partial discharges by observing current and voltage waveforms during breakdown voltage testing. By checking for partial discharges, which can lead to insulation breakdown, you can ascertain whether a coil contains any latent defects.

Measuring Motor and Winding Insulation Resistance and Breakdown Voltage

Page 16

Carry out insulation resistance and breakdown voltage testing. Ensure a high level of safety by testing the state of insulation as part of shipping inspections.

Measuring Winding Resistance

Page 17

Check for wire breaks by measuring winding resistance with a high level of precision. Check for incorrect wire thickness and turn count by using a high-precision resistance meter to make the measurements.

Measuring Motor Coil Inductance

Page 18

Measure winding inductance. Check phase balance, motor dynamic performance, RPM variations, and compatibility of the driver and motor.

Measuring Motor Weld Resistance

Page 19

Test weld quality (check for weld defects) in rectangular wire stators using a DC resistance meter with high resolution and measurement accuracy.

Design/Development

Evaluating Inverter Motor Efficiency and Loss

Simultaneously measure inverter input and output power, and motor output. Evaluate inverter, motor, and overall system efficiency and loss in an accurate and highly reproducible manner.

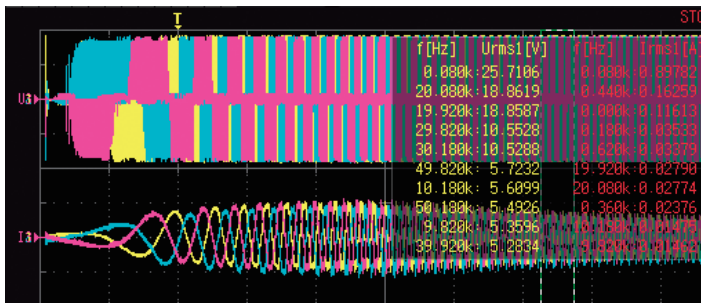
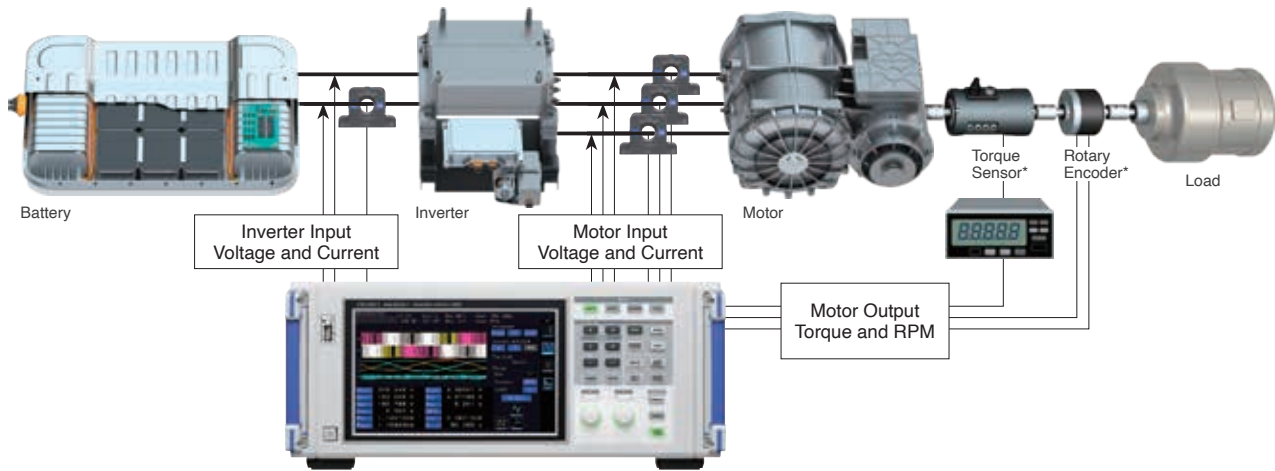
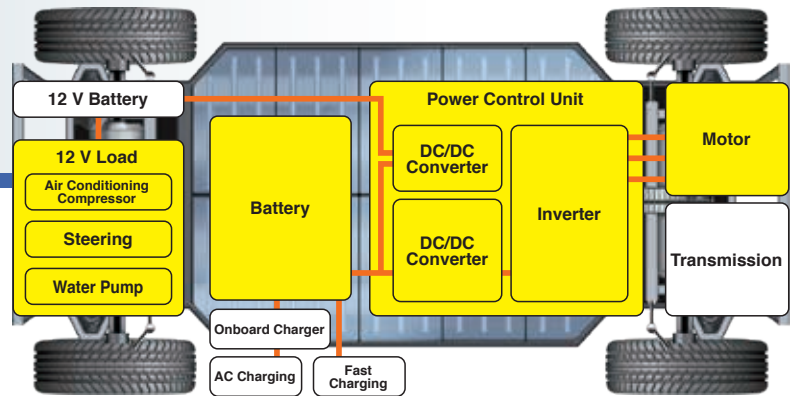

Analyzing Waveforms at Motor Start

Reliably capture and analyze instantaneous waveforms at the start of motor operation.

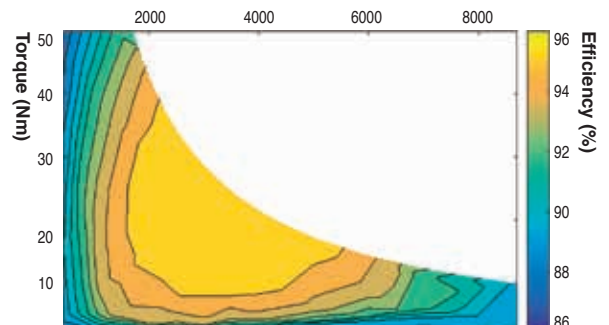

Efficiency/Loss Map

Created using measurement data and MATLAB. (MATLAB is a registered trademark of MathWorks.)

Equipment Used



POWER ANALYZER
PW6001



AC/DC CURRENT SENSOR
CT6875, CT6876

PW6001

- Power measurement (6 channels with 1 instrument or up to 12 channels by connecting 2 instruments)
- Basic accuracy (power) of $\pm 0.05\%$
- Waveform analysis without an oscilloscope; triggers specifically designed for motor analysis

CT6875, CT6876

- 500 A AC/DC, DC to 2 MHz (CT6875)
- 1000 A AC/DC, DC to 1.5 MHz (CT6876)
- Basic accuracy (power) of $\pm 0.048\%$

* Please prepare the torque sensor and rotary encoder separately.

Design/Development

Inverter Motor ECU Measurement and Calibration

Make quick work of PCU calibration by taking advantage of PW6001 and INCA¹ link functionality so that you can use the PW6001 to perform accurate power and motive power measurement. You can simultaneously monitor CAN bus data and ECU RAM values.

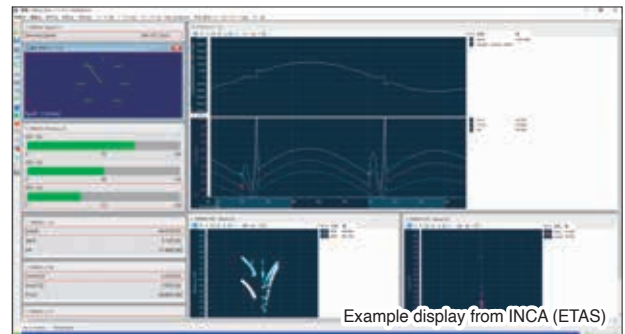
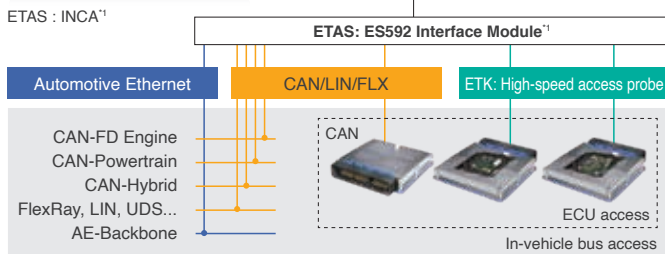
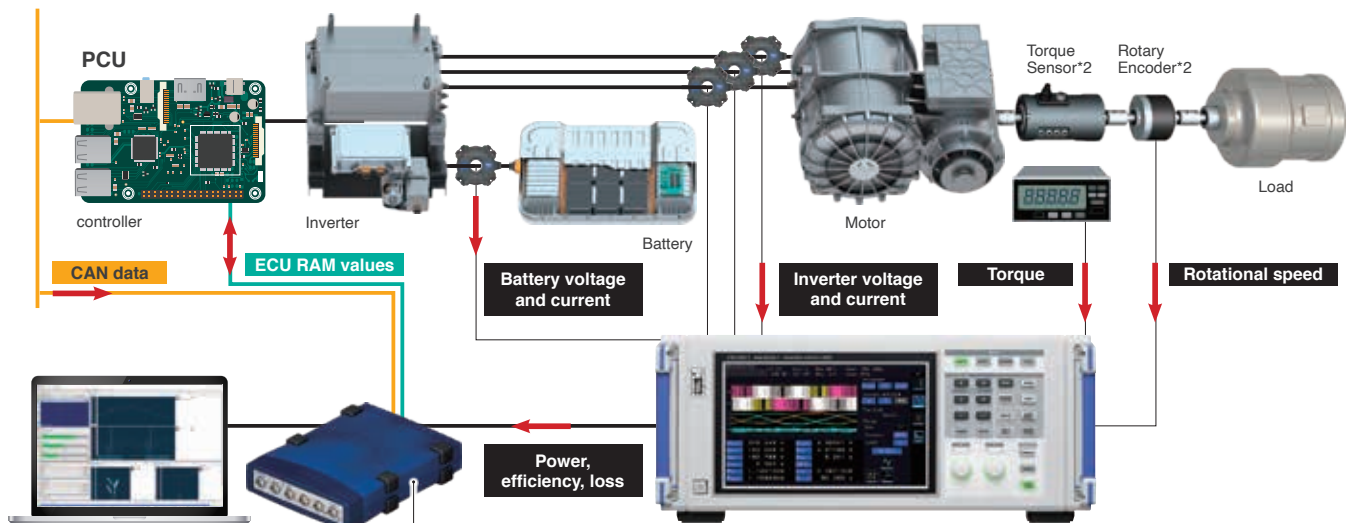
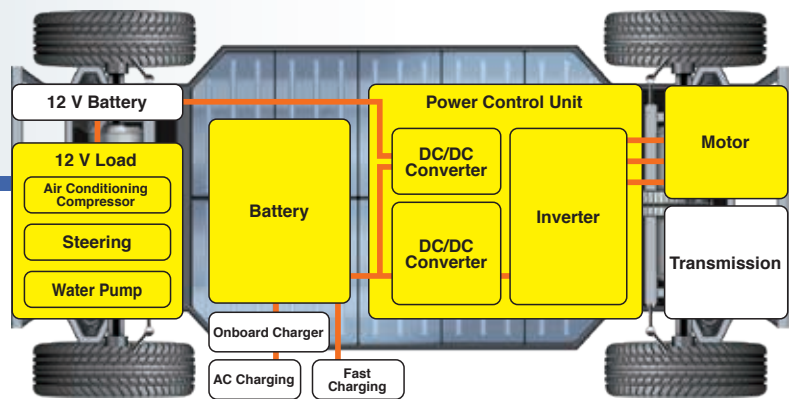

Increase efficiency of measurement experiments and calibration INCA measurement, calibration, and diagnosis tool¹

- Parameters can be rewritten during PCU operation
- High-speed monitoring of ECU RAM
- Aggregate data from multiple measurement system and buses into one intensive software

Comparison of measured values from a connected Power Analyzer PW6001, against CAN data and ECU RAM values

Equipment Used



POWER ANALYZER PW6001



AC/DC CURRENT SENSOR CT6904, 6904-60

PW6001

- Power measurement (6 channels with 1 instrument or up to 12 channels by connecting 2 instruments)
- Basic accuracy (power) of $\pm 0.05\%$
- Waveform analysis without an oscilloscope; triggers specifically designed for motor analysis

CT6904, CT6904-60

- 500 A AC/DC, DC to 4 MHz (CT6904)
- 800 A AC/DC, DC to 4 MHz (CT6904-60)
- Basic accuracy (power) of $\pm 0.048\%$

ETAS¹ Inquiries concerning ETAS tools should be directed to www.etas.com.

¹ Please prepare the torque sensor and rotary encoder separately.

Design/Development

Identifying PMSM Motor Parameters

Identify more accurate motor control motor control by using motor parameters measured under actual operating conditions in upstream design processes.

PMSM
Permanent magnet synchronous motors (PMSMs) have been attracting attention in recent years as a type of 3-phase AC motor that can deliver low energy loss and significantly reduced power consumption.

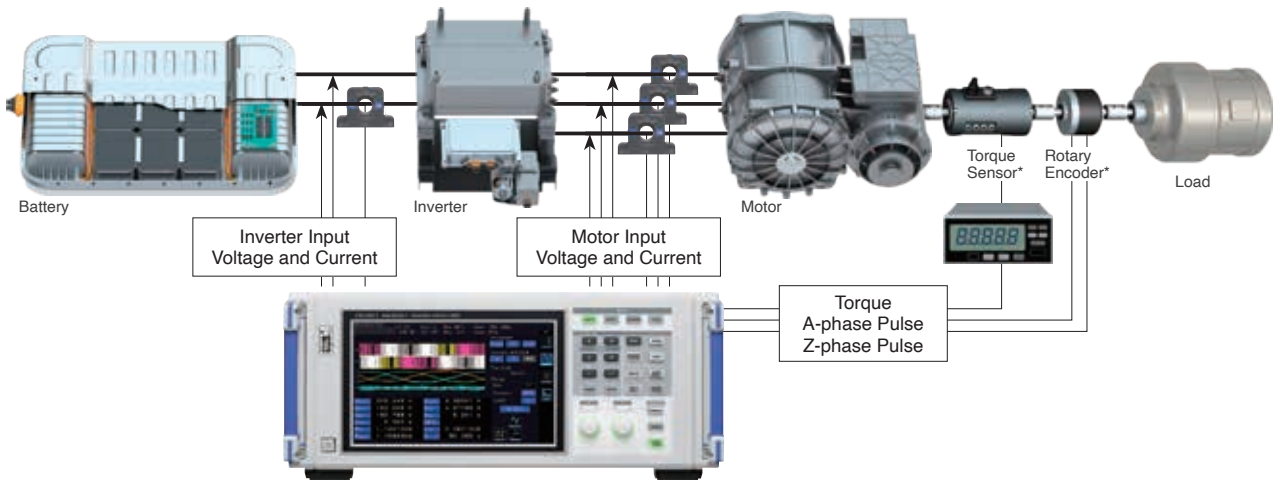
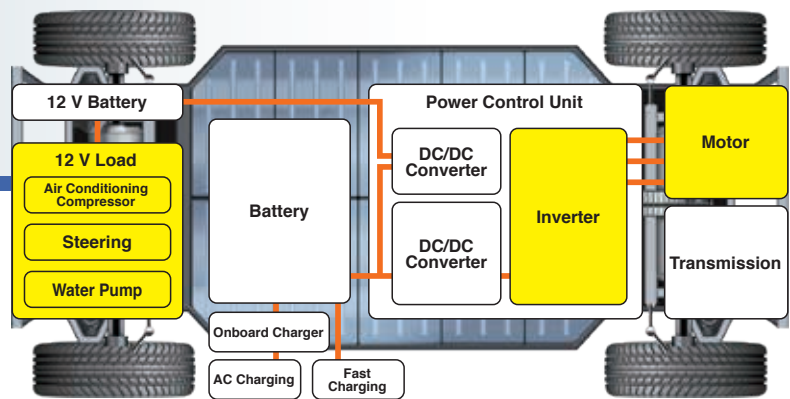

Identifying Advanced Motor Control

In order to identify advanced motor control, it is necessary to take into account the current dependence of the d-axis and q-axis inductance L_d and L_q , which in the past were treated as constants. The PW6001 can carry out d-axis and q-axis vector analysis of voltage and current during motor operation. Since that data can be used to calculate L_d and L_q in real time, it is possible to measure the current saturation characteristics of motor parameters.

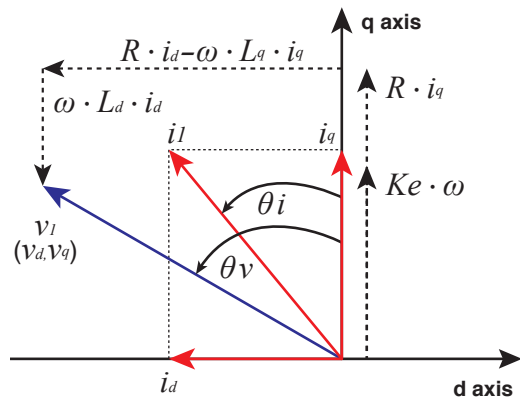

$$L_d = \frac{v_q - K_e \cdot \omega - R \cdot i_q}{\omega \cdot i_d} \quad L_q = \frac{R \cdot i_d - v_d}{\omega \cdot i_q}$$

Equipment Used

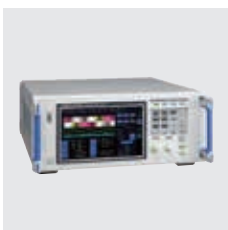

POWER ANALYZER
PW6001



AC/DC CURRENT SENSOR
CT6875, CT6876

PW6001

- Provides electrical angle measurement functionality that is needed to analyze vector control.
- Can display voltage and current vectors based on the d- and q-axes.
- Provides user-defined numerical calculation functionality that is useful when measuring motor parameters.

CT6875, CT6876

- 500 A AC/DC, DC to 2 MHz (CT6875)
- 1000A AC/DC, DC to 1.5MHz (CT6876)
- Basic accuracy (power) of $\pm 0.048\%$

*Please prepare the torque sensor and rotary encoder separately.

Design/Development

Test Automobile Fuel Economy

Taking fuel economy measurements that comply with WLTP international standards requires the precise measurement of current integration and power integration for the recharging/discharging of each battery in the system. High accuracy clamp current sensors, the excellent DC accuracy of the PW3390, and the ability to integrate current and power at 50 ms intervals are extremely effective in meeting this application.

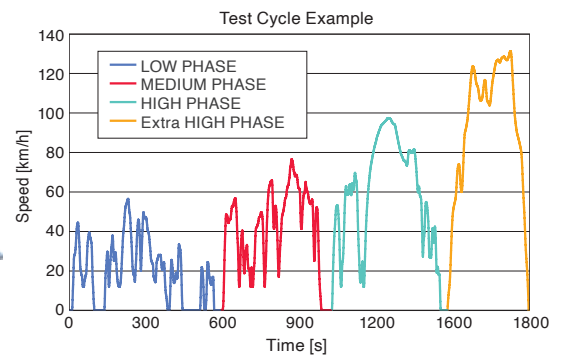
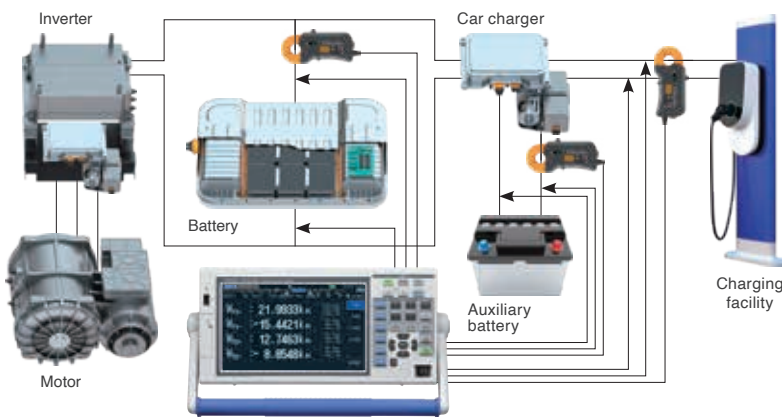
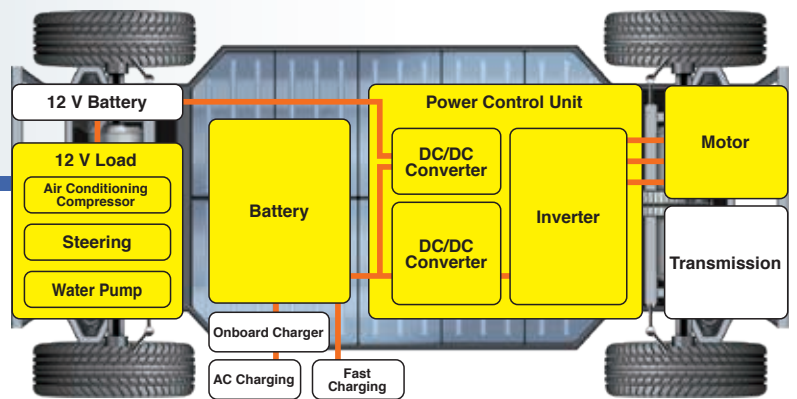

Example of DC Power Fluctuation

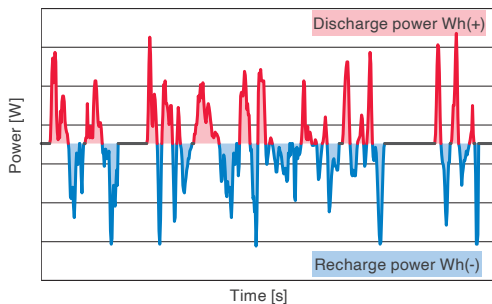

High Accuracy Sensor, Clamp Type Sensitivity Fluctuation due to Temperature

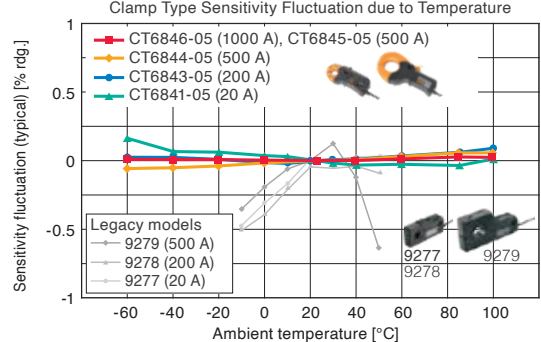

Current and Power Integration Function by Polarity

DC integration measurement integrates the recharging power and discharging power by polarity for every sample at 500 kS/s, and measures positive-direction power magnitude, negative-direction power magnitude, and the sum of positive- and negative-direction power magnitude during the integration period. Accurate measurement of recharging power and discharging power is possible even if there is rapid repetition of battery recharging/discharging.

Optimal Current Sensors for Automotive Testing

Easily connect high accuracy clamp-type sensors without cutting the cables. Sensors operate over a temperature range of -40°C to 85°C (-40°F to 185°F), characteristics that enable highly accurate measurements even inside the engine room of a car.

Equipment Used



POWER ANALYZER PW3390



AC/DC CURRENT PROBE CT684X Series

PW3390

- Basic accuracy (power) of $\pm 0.04\%$ rdg $\pm 0.05\%$ f.s

CT684X Series

- 20A AC/DC, DC to 1MHz (CT6841-05)
- 200A AC/DC, DC to 500kHz (CT6843-05)
- 500A AC/DC, DC to 200kHz (CT6844-05)
- 500A AC/DC, DC to 100kHz (CT6845-05)
- 1000A AC/DC, DC to 20kHz (CT6846-05)

Design/Development

Measuring Motor Temperature

Apply thermocouples to the motor frame and winding to record temperature variations. Display and record differences in temperature relative to the measurement environment as a waveform in real time.

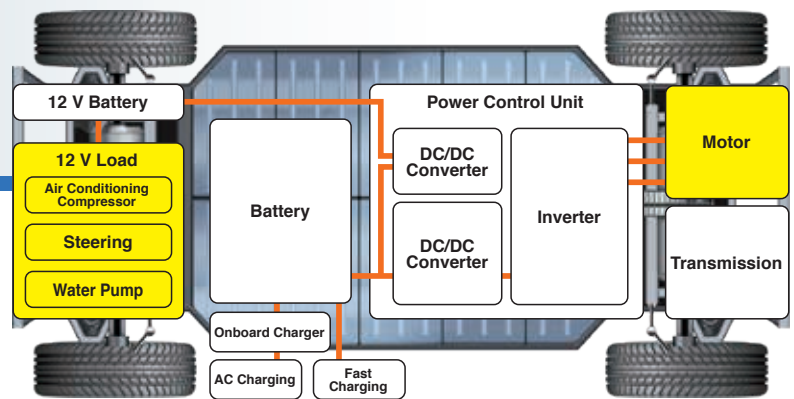

Accommodates up to four units

- Voltage: from 1 ms sampling
- Temperature: from 10 ms sampling
- Strain: from 1 ms sampling
- Humidity: from 10 ms sampling
- Resistance: from 10 ms sampling



U8550



Ambient Temperature

Winding Temperature

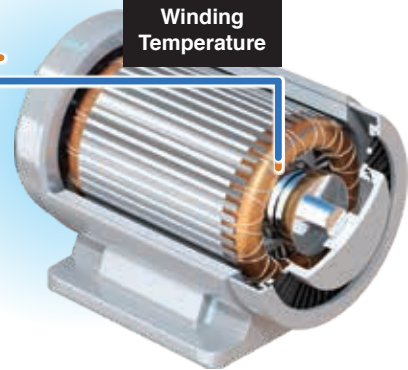

LR8450

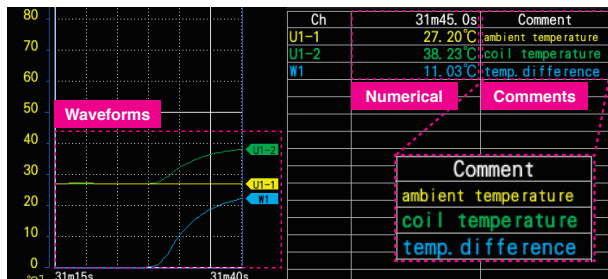

Formula	Formula
F1	=(I[MUB-2]) - (I[MUB-1]) + (I[MUB-1]) + (I[MUB-1]) + (I[MUB-1]) + (I[MUB-1])
F2	=(I[MUB-1]) + (I[MUB-1]) + (I[MUB-1]) + (I[MUB-1]) + (I[MUB-1]) + (I[MUB-1])
F3	=(I[MUB-1]) + (I[MUB-1]) + (I[MUB-1]) + (I[MUB-1]) + (I[MUB-1]) + (I[MUB-1])
F4	=(I[MUB-1]) + (I[MUB-1]) + (I[MUB-1]) + (I[MUB-1]) + (I[MUB-1]) + (I[MUB-1])
F5	=(I[MUB-1]) + (I[MUB-1]) + (I[MUB-1]) + (I[MUB-1]) + (I[MUB-1]) + (I[MUB-1])
F6	=(I[MUB-1]) + (I[MUB-1]) + (I[MUB-1]) + (I[MUB-1]) + (I[MUB-1]) + (I[MUB-1])
F7	=(I[MUB-1]) + (I[MUB-1]) + (I[MUB-1]) + (I[MUB-1]) + (I[MUB-1]) + (I[MUB-1])
F8	=(I[MUB-1]) + (I[MUB-1]) + (I[MUB-1]) + (I[MUB-1]) + (I[MUB-1]) + (I[MUB-1])
F9	=(I[MUB-1]) + (I[MUB-1]) + (I[MUB-1]) + (I[MUB-1]) + (I[MUB-1]) + (I[MUB-1])
F10	=(I[MUB-1]) + (I[MUB-1]) + (I[MUB-1]) + (I[MUB-1]) + (I[MUB-1]) + (I[MUB-1])
F11	=(I[MUB-1]) + (I[MUB-1]) + (I[MUB-1]) + (I[MUB-1]) + (I[MUB-1]) + (I[MUB-1])
F12	=(I[MUB-1]) + (I[MUB-1]) + (I[MUB-1]) + (I[MUB-1]) + (I[MUB-1]) + (I[MUB-1])
F13	=(I[MUB-1]) + (I[MUB-1]) + (I[MUB-1]) + (I[MUB-1]) + (I[MUB-1]) + (I[MUB-1])

Display Waveforms, Values, and Comments on The Screen

The instrument can simultaneously display waveforms and numerical values. Recorded data can be identified easily since user-entered comments can be displayed along with the data.

Record The Differences Between The Ambient Temperature and The Winding Temperature

By configuring calculation formulas with the waveform calculation function, you can record the differences between temperature measurements along with the measurement results.



MEMORY HILOGGER LR8450



VOLTAGE/TEMP UNIT U8550

LR8450

The instrument accommodates various measurement units. These units can measure not only temperature, but also voltage and strain at a 1 ms sampling period.

LR8450-01 (wireless LAN model)

The LR8450-01 can accommodate wireless units such as the LR8530 Wireless Voltage/Temp Unit, eliminating the need to wire together the instrument and unit.

Design/Development

EV and EV Motor Evaluation Using CAN/CAN FD

Accurately assess behavior during HILS testing and vehicle evaluation by simultaneously measuring control and sensor data on the CAN bus and actual analog values.

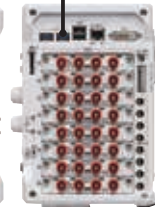
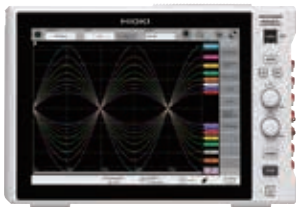
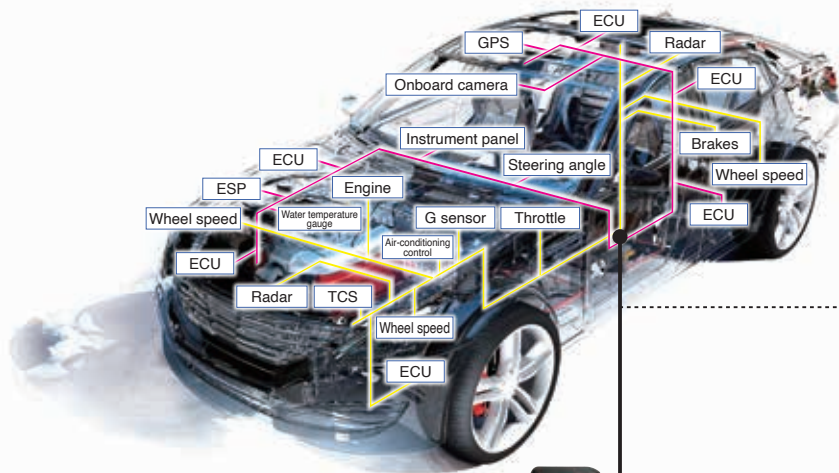
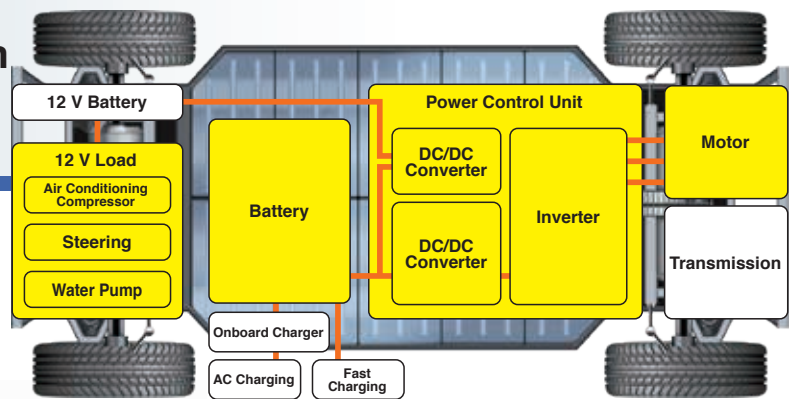

- Simple USB connection
- Capture all data on the CAN bus during measurement
- Load DBC files with the MR6000
- CAN trigger function
- Data frames
- Remote frames
- Error frames

Connect using a sub-harness or SP7001/SP7002



SP7001/SP7002
Evaluate vehicles with peace of mind by detecting signals from outside wire insulation.

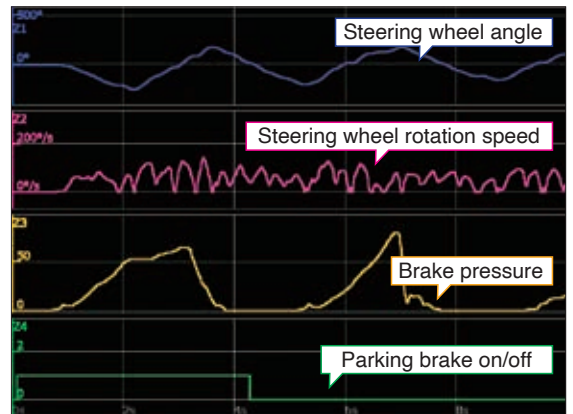

Choose signals to display after measurement

Vehicle evaluation

When dealing with parameters that are difficult to measure in assembled vehicles, you can use data on the CAN bus to assess vehicle condition and status. Use the Non-Contact CAN Sensor SP7001/SP7002 to monitor a CAN bus without the need for bothersome preparations like fabricating sub-harnesses or modifying cables. Simply remove the sensors when you're finished, without any effect on the vehicle.

Equipment Used

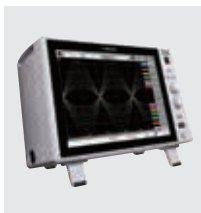

MR6000/MR6000-01



SP7001-90/SP7002-90



U8978



U8977



8970



U8969



9322



CT6843-05



L9197

- MEMORY HiCORDER MR6000/MR6000-01
- NON-CONTACT CAN SENSOR SP7001-90/SP7002-90
- 4CH ANALOG UNIT U8978
- DIFFERENTIAL PROBE 9322
- 3CH CURRENT UNIT U8977
- AC/DC CURRENT PROBE CT6843-05
- FREQ UNIT 8970
- CONNECTION CORD L9197
- STRAIN UNIT U8969
- Torque sensor*1

*1 Torque sensor (strain gage-type converter)
(For more information about the sensor, please contact the sensor manufacturer.)

Design/Development

Measuring Dynamic Motor Characteristics

Record inverter output voltage and current, torque, and RPM from motor start to stop. Calculate inverter output power, motor power, and motor efficiency using waveform calculations.

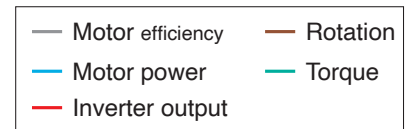
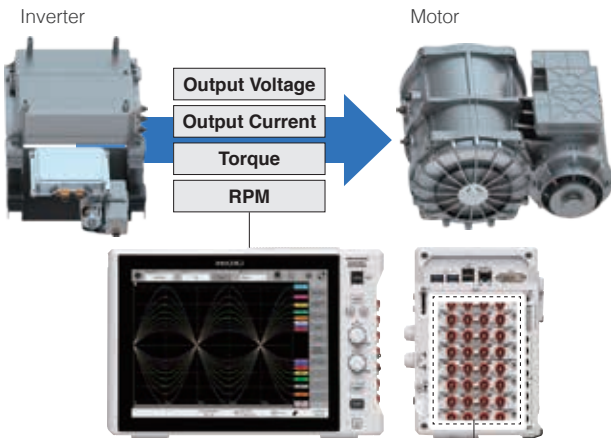
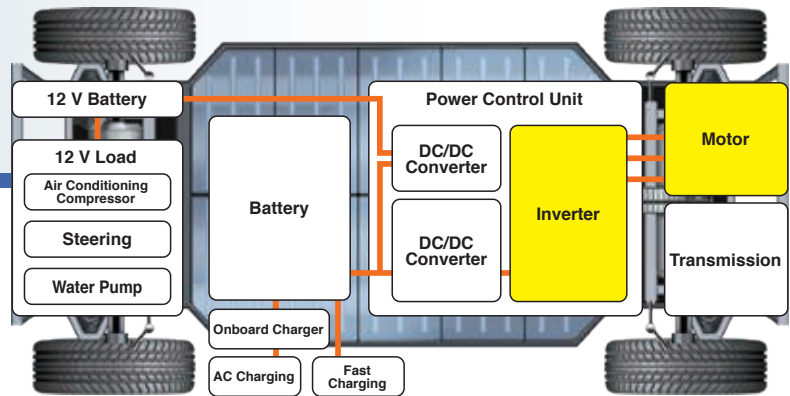

Output Voltage		Output Current	
U8978	9322	U8977	CT6841-05
Torque		RPM	
U8969	Torque Sensor*1	8970	L9197

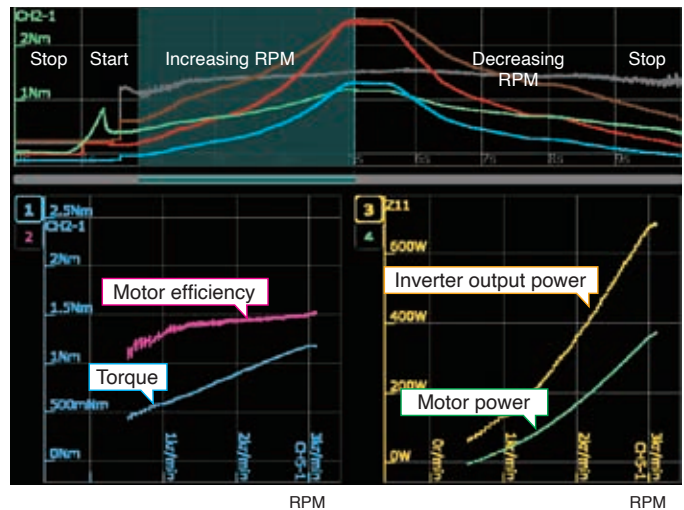

Calculate Inverter Output Power, Motor Power, and Motor Efficiency Using Waveform Calculations

Calculate motor power, motor efficiency, and inverter output power after measurement using high-speed waveform calculations and display the results using the instrument's X-Y display function. The ability to use the X-Y display for waveform calculation results as well as input signals from measurement units means you can perform a broad range of analyses. Additionally, X-Y analysis can be performed at user-specified areas of the recorded fluctuating waveform, since you can choose waveform areas for generating an X-Y display.

Equipment Used



- MEMORY HiCORDER MR6000/MR6000-01
- 4CH ANALOG UNIT U8978
- DIFFERENTIAL PROBE 9322
- 3CH CURRENT UNIT U8977
- AC/DC CURRENT PROBE CT6841-05
- FREQ UNIT 8970
- CONNECTION CORD L9197
- STRAIN UNIT U8969
- Torque sensor*1

*1 Torque sensor (strain gage-type converter) (For more information about the sensor, please contact the sensor manufacturer.)

Design/Development

Measuring Motor Torque Vibrations

Measure torque and vibration, and analyze behavior during motor operation. Discover resonance phenomena and other unpredicted frequency components by using FFT calculations to perform a frequency analysis.

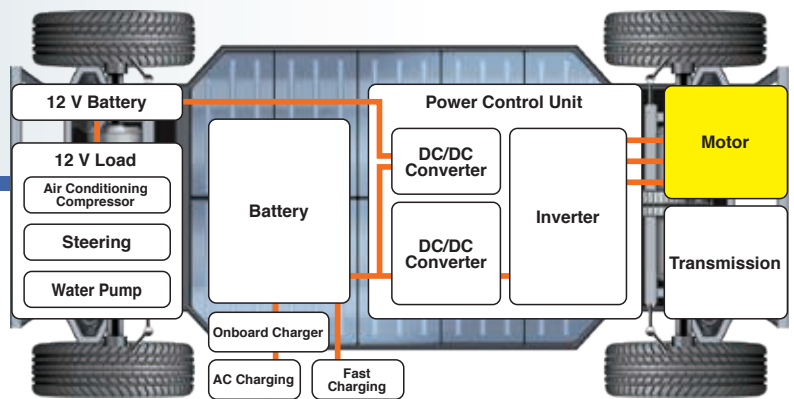

Motor

- Torque
- Vibration



Record Torque and Vibration.

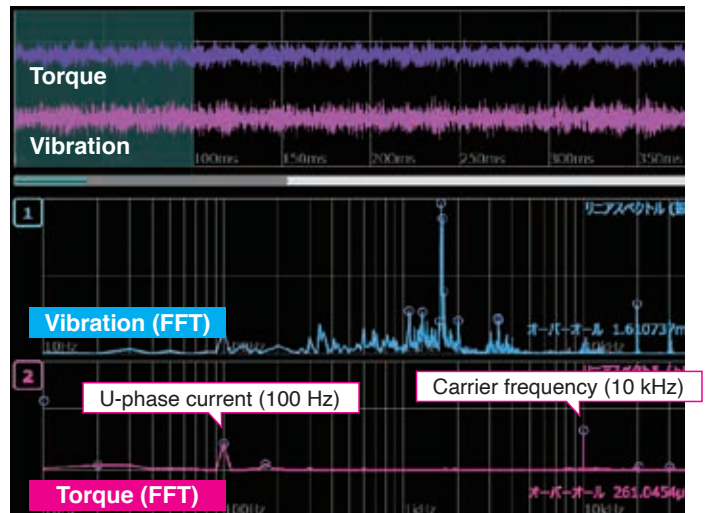

Perform Frequency Analysis Using FFT Calculations.

The MR6000/MR6000-01's FFT calculation functionality can be used to perform frequency analysis of torque and vibration signals. The MR6000/MR6000-01's FFT calculation functionality can analyze 8 phenomena simultaneous per measurement. By performing FFT analysis of signals input to different channels, it is possible to analyze frequency components occurring at the same time on different channels.

Equipment Used

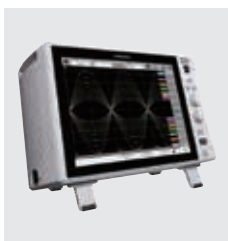

MR6000/MR6000-01



U8969 U8979

- MEMORY HiCORDER MR6000/MR6000-01
- STRAIN UNIT U8969
- Torque sensor¹
- CHARGE UNIT U8979
- Acceleration sensor²

The torque sensor (strain gage-type converter) is connected to the Strain Unit U8969 to measure torque. An acceleration sensor affixed to the chassis, on which the motor is mounted, is connected to the Charge Unit U8979 to measure vibrations being transferred to the chassis.

¹ Torque sensor (strain gage-type converter) (For more information about the sensor, please contact the sensor manufacturer.)

² Charge output type with built-in pre amp (For more information about the sensor, please contact the sensor manufacturer.)

Design/Development

Measuring Resolver Rotation Angles

A resolver is used as a sensor to accurately measure the angular position of the motor. Resolvers are used in harsh environments such as industrial motors, servers, and electric vehicles (EVs) because they can operate under demanding conditions for extended period of time. In order to increase EV range, it's necessary to control motors with a high degree of precision so as to boost their energy efficiency.

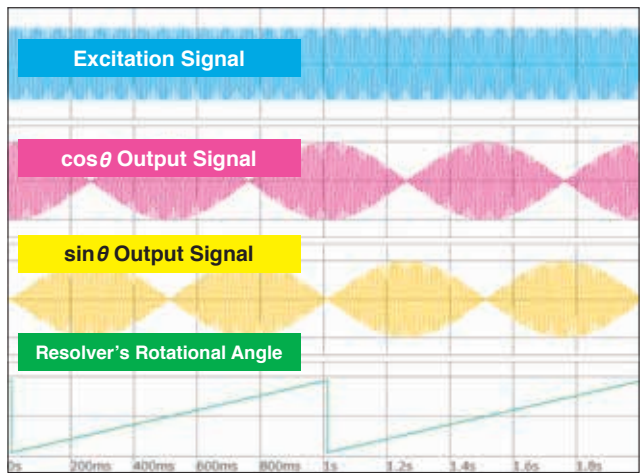
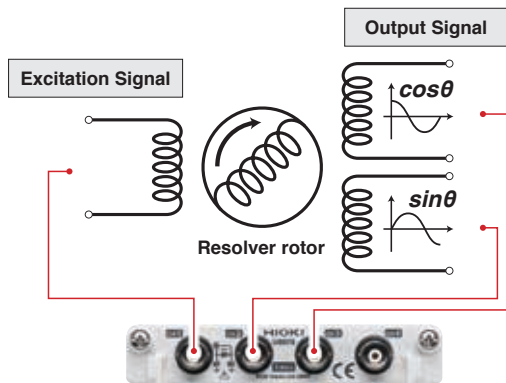
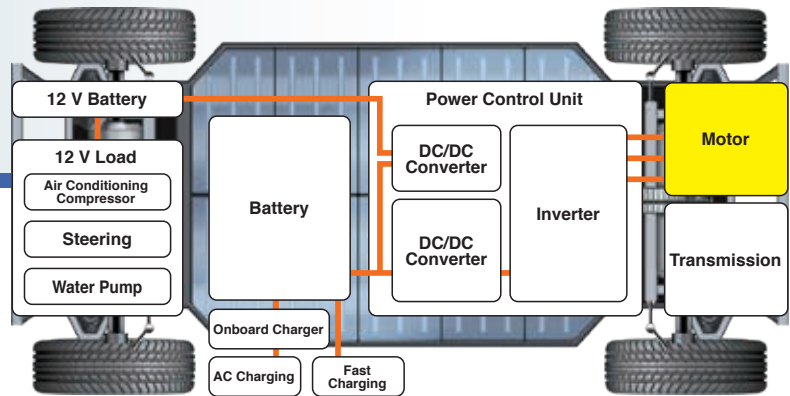

Calculate The Resolver's Rotational Angle Using Waveform Calculations.

The resolver's excitation signal and output signal ($\sin\theta$ and $\cos\theta$) are input to the 4ch Analog Unit U8978. Since setups that would have required two slots with previous models can be accommodated with a single slot, there's capacity left over to measure temperature, control signals, torque, and current signals at the same time. The instrument's waveform calculation function is used to calculate the resolver's rotational angle. Motor control sequences can be adjusted by analyzing the relationship between the resolver rotation angle and other signals.

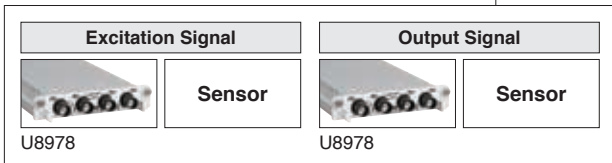

Equipment Used

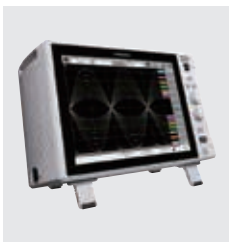

MR6000/MR6000-01



U8978

- MEMORY RECORDER MR6000/MR6000-01
- 4CH ANALOG UNIT U8978

The 4ch Analog Unit U8978 can be used to measure a resolver's excitation signal and output signal ($\sin\theta$ and $\cos\theta$) with a single unit slot. Additionally, the MR6000/MR6000-01's high-speed waveform calculation function can be used to display the rotational angle.

Production/Testing

Performing Layer Short Testing of Motor Windings

Detect insulation failures (layer shorts) and deterioration in motor windings. Generate pass/fail judgments with greater precision than conventional approaches by quantifying response waveforms.

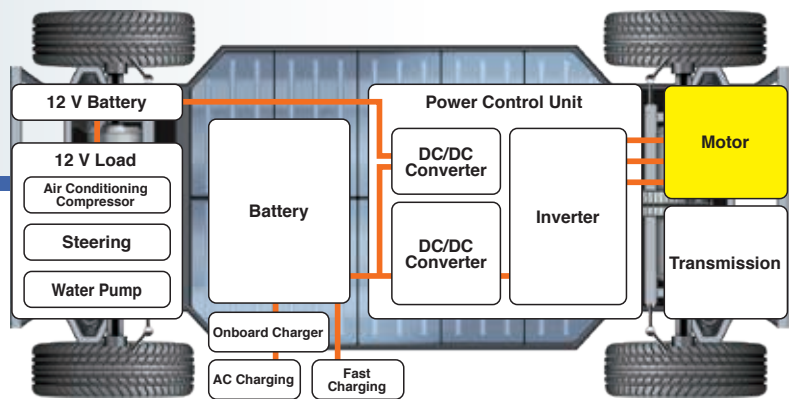

Capture Minuscule Variations That Do Not Appear in Response Waveforms

Detect minuscule defects that do not appear in response waveforms more effectively than conventional area comparison judgment (AREA, DIFF AREA) by quantifying response waveforms.

Since minuscule defects such as 1-turn shorts differ only slightly from the response waveform for a non-defective part, it's difficult to detect them using area comparison.

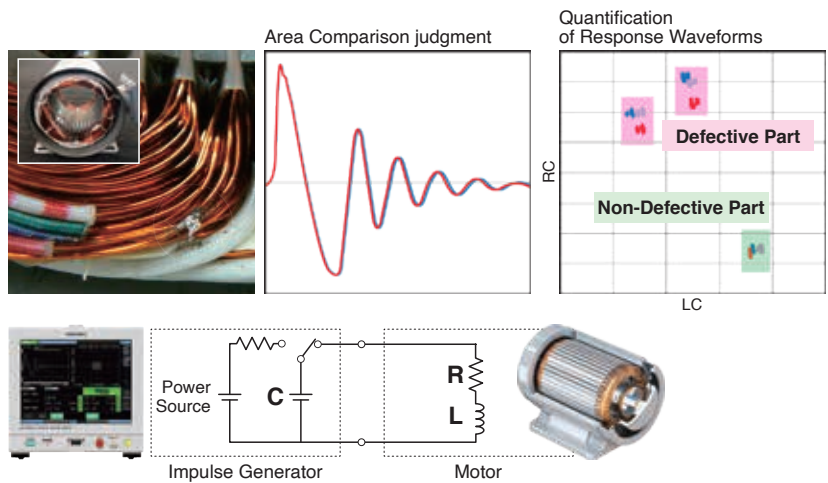

Carry Out Tests with The Rotor Installed

Changes in response waveforms caused by rotor position can also be quantified. Pass/fail judgments can then be generated by configuring non-defective and defective part areas.

Since the response waveform varies with rotor position in conventional area comparison judgment, it is not possible to make pass/fail judgments for the motor.

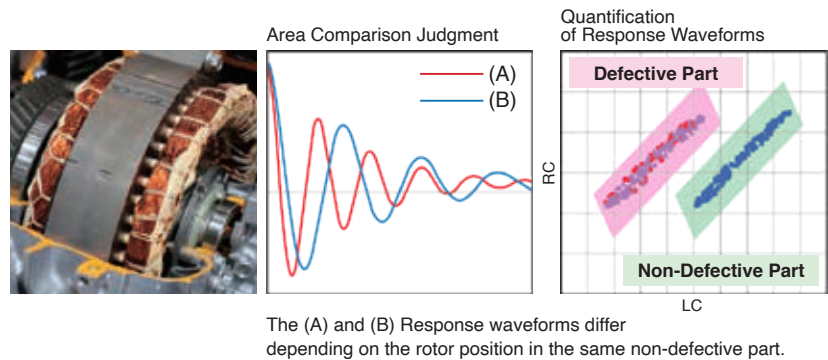

Equipment Used



IMPULSE WINDING TESTER ST4030A

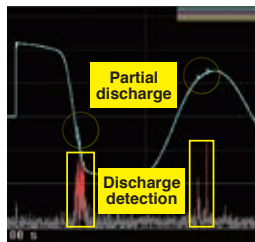

Discharge Detection Function ST9000

- High-precision waveform detection: 200 MHz, 12-bit resolution
- Quantification of response waveforms (using a patent held by Toenec Corporation)
- Detection of discharges obscured by noise (option)

Production/Testing

Performing Motor Winding Maintenance

Perform impulse testing and use the results in motor winding maintenance and trend management.

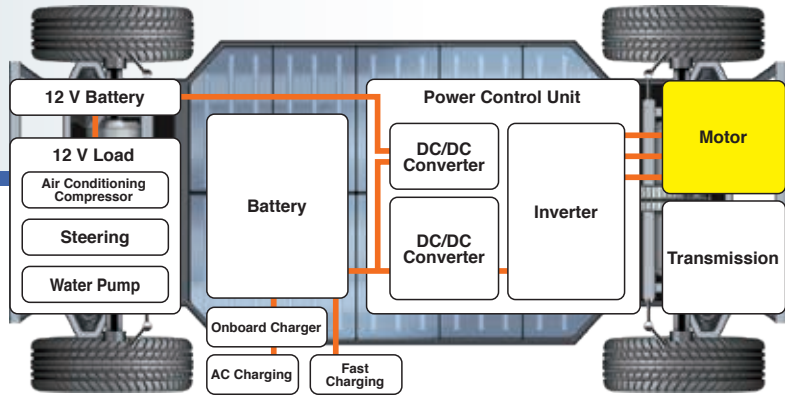

Check for Insulation Defects and Deterioration Even If No Non-Defective Part is Available

On a standard, properly configured 3-phase motor, the phases (U, V, and W) are balanced. Consequently, the response waveforms obtained when an impulse voltage is applied between phases (U-V, V-W, W-U) will be almost identical.

By tentatively identifying the response waveform obtained from one phase as the waveform for a non-defective part and comparing it to the response waveforms from the other phases, you can detect insulation failures and deterioration.

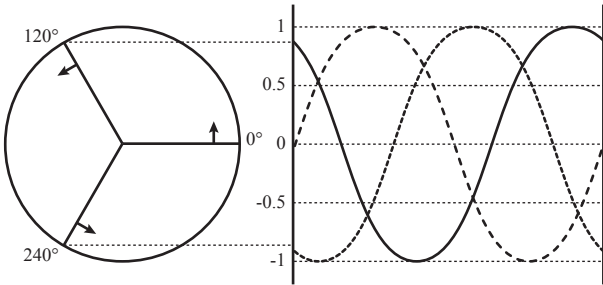

Properly Configured 3-phase Motor Phases (U, V, W) are Balanced.

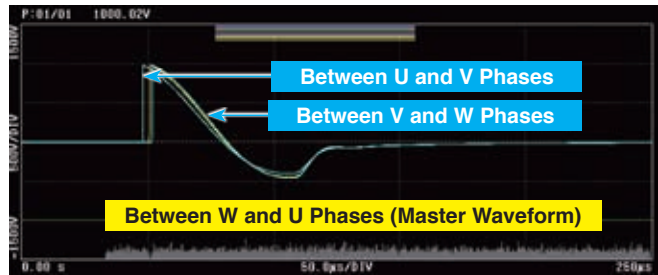

Non-Defective Product Response Waveform

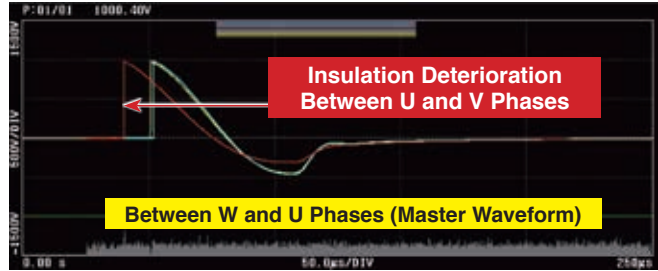

Example of Response Waveform Exhibiting Insulation Deterioration

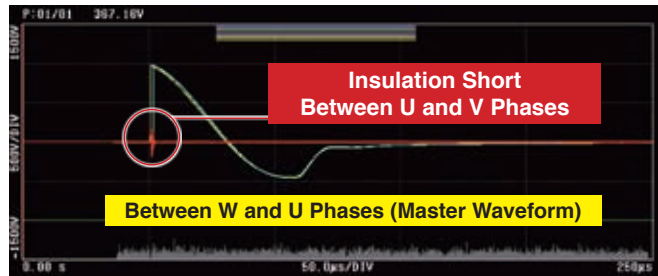

Example of Response Waveform Exhibiting Insulation Short

Equipment Used



IMPULSE WINDING TESTER ST4030A

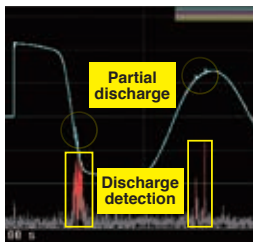

Discharge Detection Function ST9000

- High-precision waveform detection: 200 MHz, 12-bit resolution
- Quantification of response waveforms (using a patent held by Toenec Corporation)
- Detection of discharges obscured by noise (option)

Production/Testing

Observation of Partial Discharges During Breakdown Voltage Testing

Detect partial discharges by observing current and voltage waveforms during breakdown voltage testing. By checking for partial discharges, which can lead to insulation breakdown, you can ascertain whether a coil contains any latent defects.

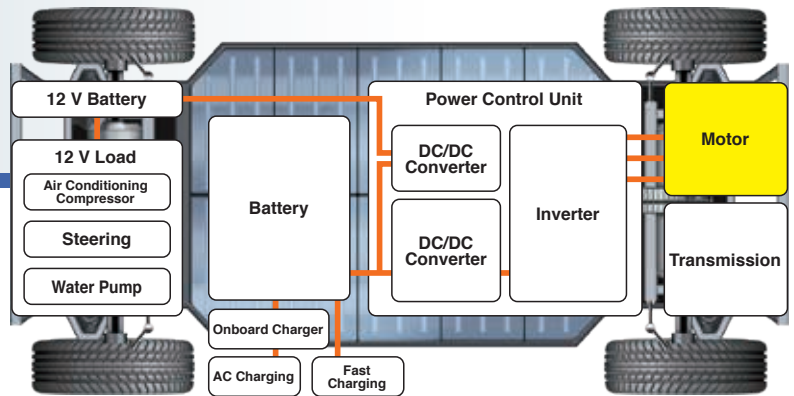

Observation of partial discharges while using a hipot tester as a voltage source

Apply a high voltage after connecting the tester's positive terminal to a stator's U-phase and its negative terminal to the stator's V-phase while the stator's neutral point remains unconnected. Then compare variations in the voltage at which partial discharges begin in a stators with good insulation and in a stator whose U- and V-phase coils are in contact.

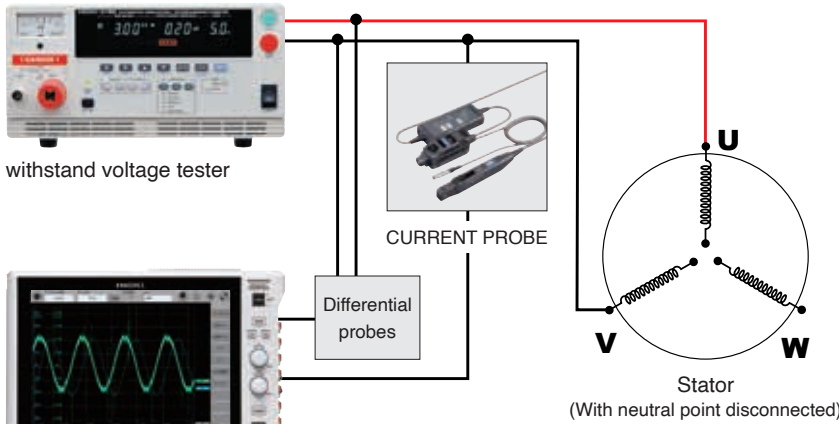

withstand voltage tester

Waveform observation

Pseudo-defect

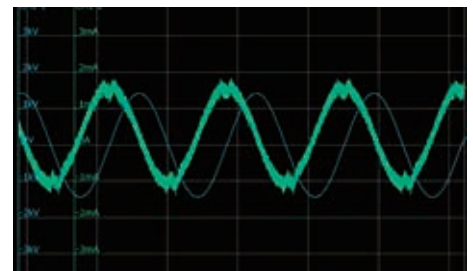
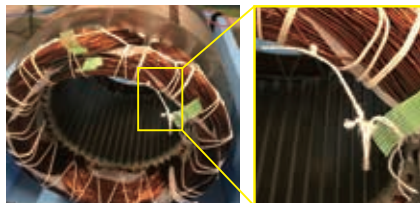

Current and voltage waveforms when 1.0 kV AC is applied to a non-defective stator



Partial discharges occur

Current and voltage waveforms when 1.5 kV AC is applied to a non-defective stator

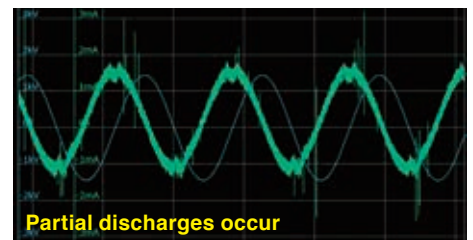

Partial discharges occur

Current and voltage waveforms when 1.0 kV AC is applied to a stator with a pseudo-defect

Equipment Used



AUTOMATIC INSULATION/
WITHSTANDING HIPOTESTER
3153



MEMORY HICORDER
MR6000



CURRENT PROBE
CT6711

3153

- Test voltage: 60 Hz AC
- Increasing from 1000 V in 100 V increments

MR6000

- Sampling speed: 200 MS/s
- Storage time: 2.5 s
- Coupling method: AC coupling

CT6711

- Range: 0.5 A
- Output range: 10 V/A
- Frequency band: DC to 120 MHz

Production/Testing

Measuring Motor and Winding Insulation Resistance and Withstand Voltage

Carry out insulation resistance and withstand voltage testing. Ensure a high level of safety by testing the state of insulation as part of shipping inspections.

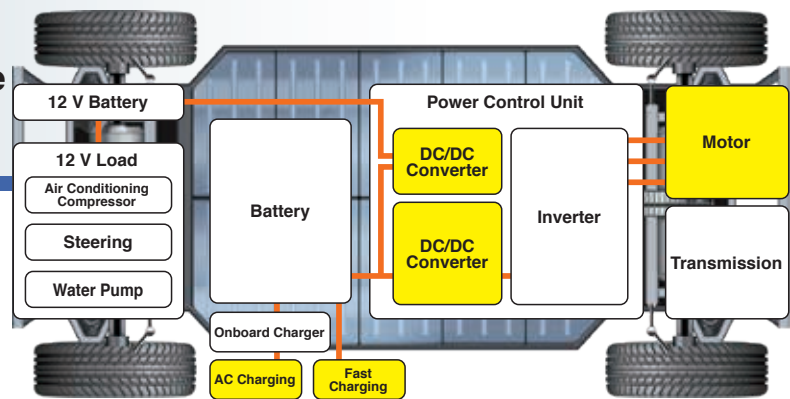

For Use in Shipping Inspections Measure Insulation Resistance and Withstand Voltage

Insulation deterioration leads to the risk of electric shock and ground faults. The condition of insulation is tested during shipping inspections to ensure product safety.

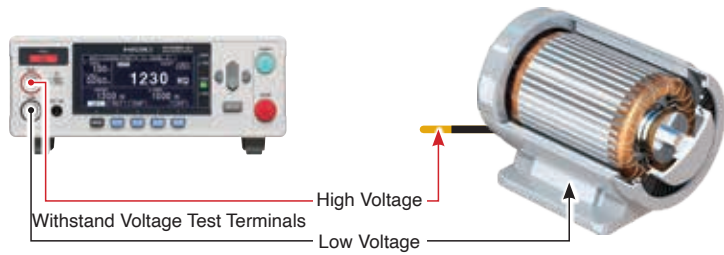

Results of Insulation Deterioration

Risk of Electric Shock

Risk of Ground Faults

Contact Check Function to Ensure Reliable Testing

Incomplete probe contact and wire breaks in cables can prevent proper contact with the device under test. In such cases, defective parts can be misidentified as non-defective. Contact check functionality provides an effective means of ensuring test integrity.

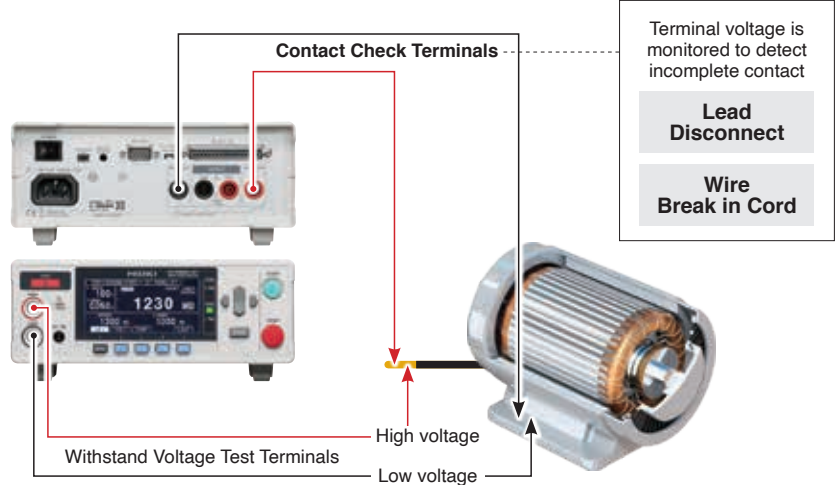

Equipment Used



INSULATION TESTER
ST5520



AUTOMATIC INSULATION/
WITHSTANDING HI-TESTER
3153

Contact checks can be performed continuously without affecting measured values.

ST5520

- 25 V to 1000 V DC, 0.002 MΩ to 9990 MΩ

3153

- AC withstand voltage testing: 0.2 kV to 5 kV AC, 100 mA
- Insulation resistance testing: 50 V to 1200 V DC, 0.100 MΩ to 9999 MΩ

Production/Testing

Measuring Winding Resistance

Check for wire breaks by measuring winding resistance with a high level of precision. Check for incorrect wire thickness and turn count by using a high-precision resistance meter to make the measurements.

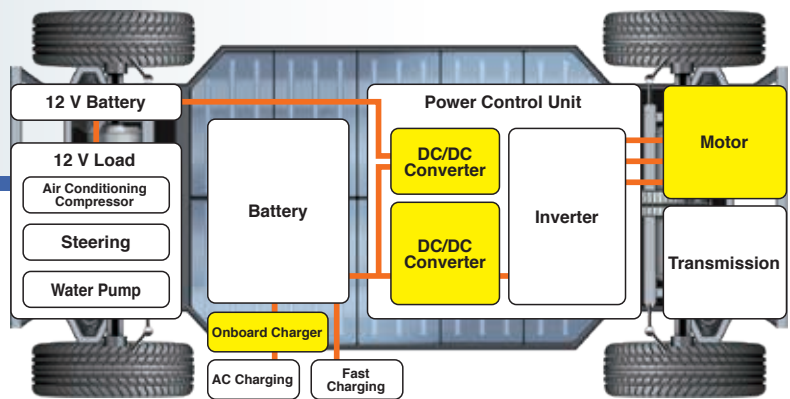

Testing Winding Quality with Resistance Measurement

To operate a motor efficiently, it's necessary to apply a large current. To accommodate such currents, thick windings with low resistance are essential.

What can resistance values tell us?

- Incorrect Wire Thickness
- Incorrect Number of Turns
- Winding Shorts



Motor Windings

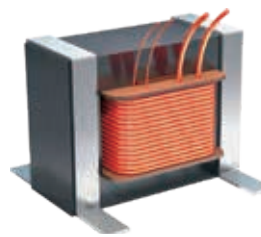

Transformer Winding

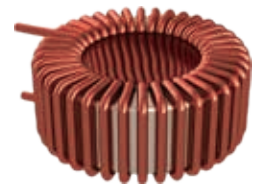

Coil Winding

Performance Required for Resistance Measurement

Winding resistance, which is continually falling as technology progresses, can be accurately measured using a resistance meter.

Required Performance

- Low-Resistance Measurement
- Ambient Temperature Correction

When measuring large windings, where low resistance values are increasingly becoming the norm, values must be managed on the order of 10 $\mu\Omega$.

It's essential to perform temperature correction since wire resistance values vary with temperature.

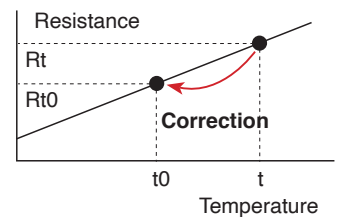

Equipment Used



RESISTANCE METER RM3545



MULTIPLEXER UNIT Z3003



RESISTANCE METER RM3548

RM3545

- High-precision resistance meter with a resolution of 0.01 $\mu\Omega$
- The RM3545-02 features an available internal multiplexer that efficiently measures resistance at multiple points.

RM3548

- Temperature correction functionality and interval measurement are convenient in temperature rise testing of motors and transformers.
- The portable form factor is ideal for measuring large motors and transformers.

Production/Testing

Measuring Motor Coil Inductance

Measure winding inductance. Check phase balance, motor dynamic performance, RPM variations, and compatibility of the driver and motor.

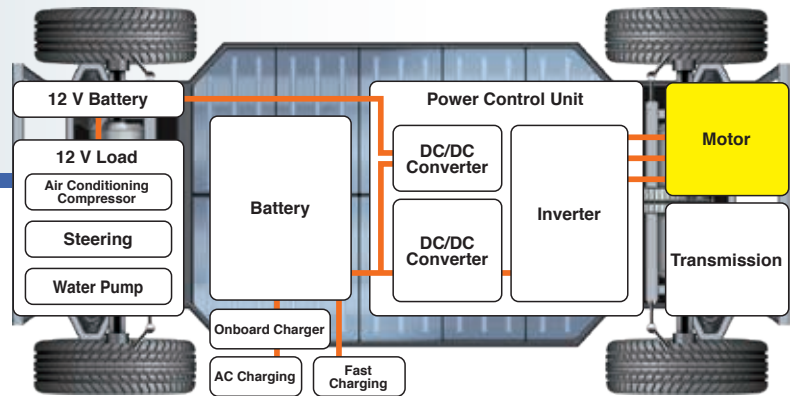

Using Winding Inductance to Test Motor Performance

What can inductance tell us?

- Phase Balance
- Motor Operating Performance
- RPM Variations
- Compatibility of Drivers and Motors

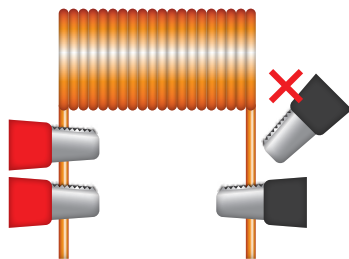
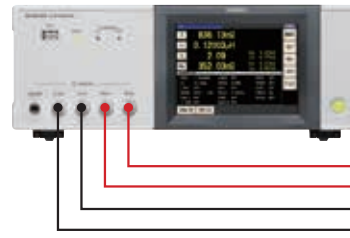

Contact Check

Preventing erroneous measurement to ensure reliable testing

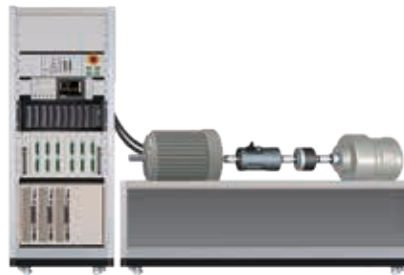

Cable Length: 4 m

Accuracy is guaranteed for measurement cables up to 4 m in length. Compatible with large equipment designed for use with motors

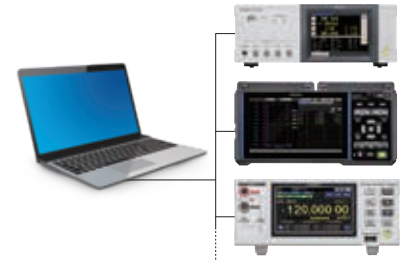

Labview Driver Available

Use in combination with other instruments.

Equipment Used



LCR METER
IM3536

- DC and 4Hz to 8MHz (up to 10MHz special order available) measurement frequency
- Manage winding inductance values using the judgment function.

Production/Testing

Measuring Motor Weld Resistance

Test weld quality (check for weld defects) in rectangular wire stators using a DC resistance meter with high resolution and measurement accuracy.

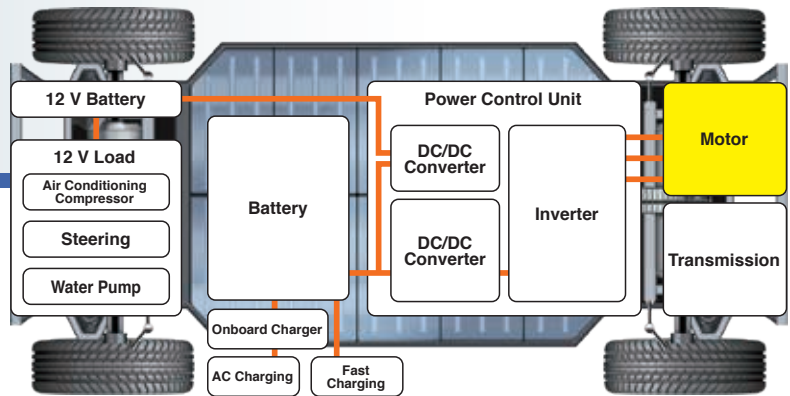

Rectangular Wire Stators

Rectangular copper wire that has been bent is affixed to the stator core, and rectangular wires from the same phase are welded together by a robot. Incomplete bonds can lead to latent defects due to insufficient weld penetration, cracking, and pinhole formation.

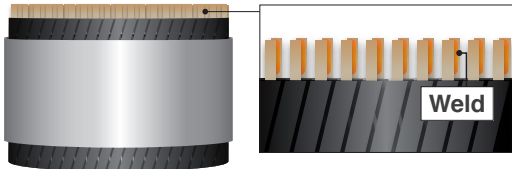

Rectangular Wire Stator



Testing Weld Quality with DC Resistance Measurement

Probes for detecting voltage contact both side of welding point. The RM3545 can measure resistance of welding. You can easily built measurement system by use the Z3003 multiplexer unit with the RM3545.

Since the Resistance Meter RM3545 can measure resistance at a resolution of 10 nΩ in the 10 mΩ range, the weld state can be judged on the basis of DC resistance values.

*Use the Temperature Sensor Z2001 with the RM3545's temperature correction function.

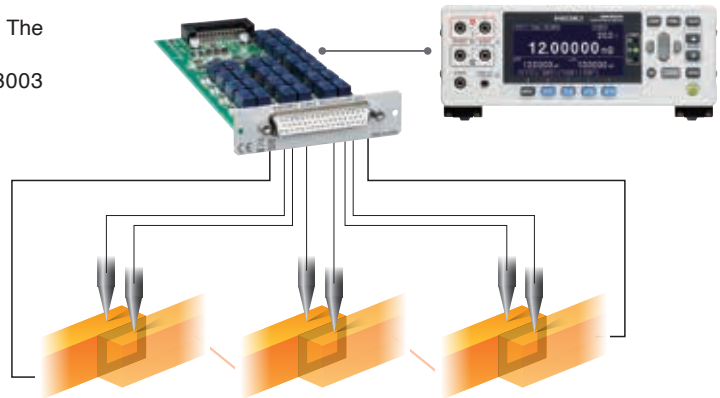

Equipment Used



RESISTANCE METER
RM3545-02



MULTIPLEXER UNIT
Z3003

- World-class Accuracy and Digit Count
- Measurement basic accuracy of 0.006%
 - Display count of 6 digits

Accurate Measurement of Super-low Resistance Values Allows quantification of the status of rectangular wire welds, playing a positive role when testing in the field.

HIOKI
HIOKI E. E. CORPORATION

HEADQUARTERS

81 Koizumi,
Ueda, Nagano 386-1192 Japan
<https://www.hioki.com/>



Scan for all
regional contact
information

Note: Company names and product names appearing in this catalog are trademarks or registered trademarks of various companies.

DISTRIBUTED BY